

DEPARTMENT OF THE ARMY TECHNICAL MANUAL

---

TEST SET  
TS-147D/UP

This reprint includes all changes in effect at the time of publication; changes 1 and 2.



**5**

SAFETY STEPS TO FOLLOW IF SOMEONE IS THE VICTIM OF ELECTRICAL SHOCK

**1**

DO NOT TRY TO PULL OR GRAB THE INDIVIDUAL

**2**

IF POSSIBLE, TURN OFF THE ELECTRICAL POWER

**3**

IF YOU CANNOT TURN OFF THE ELECTRICAL POWER, PULL, PUSH OR LIFT THE PERSON TO SAFETY USING A DRY WOODEN POLE OR A DRY ROPE OR SOME OTHER INSULATING MATERIAL

**4**

SEND FOR HELP AS SOON AS POSSIBLE

**5**

AFTER THE INJURED PERSON IS FREE OF CONTACT WITH THE SOURCE OF ELECTRICAL SHOCK, MOVE THE PERSON A SHORT DISTANCE AWAY AND IMMEDIATELY START ARTIFICIAL RESUSCITATION

CHANGE }  
No. 2 }

HEADQUARTERS,  
DEPARTMENT OF THE ARMY  
WASHINGTON, D.C., 20 April 1977

**TEST SET TS-147D/UP**

TM 11-1247B, May 1956, is changed as follows:  
*Page 1.1* paragraph 1.1 Delete paragraph 1.1 and substitute:

**1.1. Indexes of Publications**

- a. *DA Pam 310-4.* Refer to the latest issue of DA Pam 310-4 to determine whether there are new editions, changes, or additional publications pertaining to the equipment.
- b. *DA Pam 310-7.* Refer to DA Pam 310-7 to determine whether there are modification work orders (MWO's) pertaining to the equipment.

Paragraph 1.2 Delete paragraph 1.2 and substitute:

**1.2. Forms and Records**

- a. *Reports of Maintenance and Unsatisfactory Equipment.* Maintenance for: as, records, and reports which are to be used by maintenance personnel at all maintenance levels are listed in and prescribed by TM 38-750.
- b. *Report of Packaging and Handling Deficiencies.* Fill out and forward DD Form 6 (Packaging Improvement Report) as prescribed by AR 700-58/ NAVSUPINST 4030.29/AFR 71-13/MCO P4030.29A, and DSAR 4145.8.
- c. *Discrepancy in Shipment Report (DISREP) (SF 361).* Fill out and forward Discrepancy in Shipment report (DISREP) (SF 361) as prescribed in AR 55-38/NAVSUPINST 4610.33A/AFR 75-18/MCO P4610.19B and DSAR 4500.15.

**1.3. Reporting of Errors**

Report of errors, omissions, and recommendations for improving this publications by the individual user is encouraged. Reports should be submitted on DA Form 2028 (Recommended Changes to Publications and Blank Forms) and forwarded direct to Commander, US Army Electronics Command, ATTN: DRSEL-MA-Q, Fort Monmouth, NJ 07703. A reply will be furnished directly to you.

**1.4. Reporting Equipment Improvement Recommendations (EIR)**

EIR will be prepared using DA Form 2407, Maintenance Request. Instructions for preparing EIR's are provided in TM 38-750, The Army Maintenance Management System. EIR's should be mailed directly to Commander, US Army Electronics Command, ATTN: DRSEL-MA-Q, Fort Monmouth, NJ 07703. A reply will be furnished directly to you.

**1.5. Administrative Storage**

For procedures, forms, and records, and inspections required during administrative storage of this equipment, refer to TM 740-90-1.

**1.6. Destruction of Army Electronics Materiel**

Destruction of Army electronics materiel to prevent enemy use shall be prescribed in TM 750-244-2.

*Page 6-18.* Delete unnumbered appendix, and substitute:

**APPENDIX A  
REFERENCES**

---

DA Pam 310-4	Index of Technical Manuals, Technical Bulletins, Supply Manuals (types 7, 8, and 9), Supply Bulletins, and Lubrication Orders.
DA Pam 310-7	US Army Equipment Index of Modification Work Orders.
TM 38-750	The Army Maintenance Management System (TAMMS).
TM 43-0118	Field Instructions for Painting and Preserving Electronics Command Equipment Including Camouflage Pattern Painting of Electronic Equipment Shelters.

## APPENDIX B MAINTENANCE ALLOCATION

---

### Section I. INTRODUCTION

#### B-1. General

This appendix provides a summary of the maintenance operations for TS-147D/UP. It authorizes categories of maintenance for specific maintenance functions on repairable items and components and the tools and equipment required to perform each function. This appendix may be used as an aid in planning maintenance operations.

#### B-2. Maintenance Function.

Maintenance functions will be limited to and defined as follows:

*a. Inspect.* To determine the serviceability of an item by comparing its physical, mechanical, and/or electrical characteristics with established standards through examination.

*b. Test.* To verify serviceability and to detect incipient failure by measuring the mechanical or electrical characteristics of an item and comparing those characteristics with prescribed standards.

*c. Service.* Operations required periodically to keep an item in proper operating condition, i.e., to clean (decontaminate), to preserve, to drain, to paint, or to replenish fuel, lubricants, hydraulic fluids, or compressed air supplies.

*d. Adjust.* To maintain, within prescribed limits, by bringing into proper or exact position, or by setting the operating characteristics to the specified parameters.

*e. Align.* To adjust specified variable elements of an item to bring about optimum or desired performance.

*f. Calibrate.* To determine and cause corrections to be made or to be adjusted on instruments or test measuring and diagnostic equipments used in precision measurement. Consists of comparisons of two instruments, one of which is a certified standard of known accuracy, to detect and adjust any discrepancy in the accuracy of the instrument being compared.

*g. Install.* The act of emplacing, seating, or fixing into position an item, part, module (component or assembly) in a manner to allow the proper functioning of the equipment or system.

*h. Replace.* The act of substituting a serviceable like type part, subassembly, or module (component or assembly) for an unserviceable counterpart.

*i. Repair.* The application of maintenance services (inspect, test, service, adjust, align, calibrate, replace) or other maintenance actions (welding, grinding, riveting, straightening, facing, remachining, or resurfacing) to restore serviceability to an item by correcting specific damage, fault, malfunction, or failure in a part, subassembly, module (component or assembly), end item, or system. This function does not include the trial and

error replacement of running spare type items such as fuses, lamps, or electron tubes.

*j. Overhaul.* That maintenance effort (service/action) necessary to restore an item to a completely serviceable/operational condition as prescribed by maintenance standards (i.e., DMWR) in appropriate technical publications. Overhaul is normally the highest degree of maintenance performed by the Army. Overhaul does not normally return an item to like new condition.

*k. Rebuild.* Consists of those services/actions necessary for the restoration of unserviceable equipment to a like new condition in accordance with original manufacturing standards. Rebuild is the highest degree of materiel maintenance applied to Army equipment. The rebuild operation includes the act of returning to zero those age measurements (hours, miles, etc.) considered in classifying Army equipments/components.

#### B-3. Column Entries

*a. Column 1, Group Number.* Column 1 lists group numbers, the purpose of which is to identify components, assemblies, subassemblies, and modules with the next higher assembly.

*b. Column 2, Component/Assembly.* Column 2 contains the noun names of components, assemblies, subassemblies, and modules for which maintenance is authorized.

*c. Column 3, Maintenance functions.* Column 3 lists the functions to be performed on the item listed in column 2. When items are listed without maintenance functions, it is solely for purpose of having the group numbers in the MAC and RPSTL coincide.

*d. Column 4, Maintenance Category.* Column 4 specifies, by the listing of a "work time" figure in the appropriate subcolumn(s), the lowest level of maintenance authorized to perform the function listed in column 3. This figure represents the active time required to perform that maintenance function at the indicated category of maintenance. If the number or complexity of the tasks within the listed maintenance function vary at different maintenance categories, appropriate "work time" figures will be shown for each category. The number of -task-hours specified by the "work time" figure represents the average time required to restore an item (assembly, subassembly, component, module, end item or system) to a serviceable condition under typical field operating conditions. This time includes preparation

time, troubleshooting time, and quality assurance/ quality control time in addition to the time required to perform the specific tasks identified for the maintenance functions authorized in the maintenance allocation chart. Subcolumns of column 4 are as follows:

- C - Operator/Crew
- O - Organizational
- F - Direct Support
- H - General Support
- D - Depot

*e. Column 5, Tools and Equipment.* Column 5 specifies by code, those common tool sets (not individual tools) and special tools, test, and support equipment required to perform the designated function.

**B-4. Tool and Test Equipment Requirements (Table I).**

*a. Tool or Test Equipment Reference Code.* The numbers in this column coincide with the numbers used

in the tools and equipment column of the MAC. The numbers indicate the applicable tool or test equipment for the maintenance functions.

*b. Maintenance Category.* The codes in this column indicate the maintenance category allocated the tool or test equipment.

*c. Nomenclature.* This column lists the noun name and nomenclature of the tools and test equipment required to perform the maintenance functions.

*d. National/NATO Stock Number.* This column lists the National/NATO stock number of the specific tool or test equipment.

*e. Tool Number.* This column lists the manufacturer's part number of the tool followed by the Federal Supply Code for manufacturers (5-digit) in parentheses.

**SECTION II MAINTENANCE ALLOCATION CHART  
FOR  
TEST SET TS-147D/UP**

(1) GROUP NUMBER	(2) COMPONENT ASSEMBLY	(3) MAINTENANCE FUNCTION	(4) MAINTENANCE CATEGORY					(5) TOOLS AND EQUIPMENT
			C	O	F	H	D	
00	TEST SETS-147D/UP	Inspect Test Service Adjust Replace Repair Overhaul		0.5		1.8 2.0 1.8 1.8 2.5	3.0	13 4,6,7,9 thru 13 4,6,7.9 thru 13  1 thru 8, 10 thru 13
01	CABLE ASSEMBLIES	Test Repair				0.5 0.5		13 13

TABLE I. TOOL AND TEST EQUIPMENT REQUIREMENTS  
FOR  
TEST SET TS-147D/UP

TOOL OR TEST EQUIPMENT REF CODE	MAINTENANCE CATEGORY	NOMENCLATURE	NATIONAL/NATO STOCK NUMBER	TOOL NUMBER
1	D	ANALYZER, SPECTRUM TS-148/UP	6625-00-166-1040	
2	D	COUNTER, ELECTRONIC DIGITAL READOUT AN/USM-207	6625-00-911-6368	
3	D	PULSE GENERATOR AN/PPM-1A	6625-00-504-9603	
4	H, D	GENERATOR, SIGNAL AN/URM-44A	6625-00-990-7700	
5	D	INDICATOR, STANDING WAVE AN/USM-37D	6625-00-999-7798	
6	H, D	MULTIMETER TS-352B/U	6625-00-553-0142	
7	H, D	OSCILLOSCOPE AN/USM-281A	6625-00-228-2201	
8	D	TEST SET, ELECTRON TUBE TV-2/U	6625-00-669-0263	
9	H	TEST SET, ELECTRON TUBE TV-7D/U	6625-00-820-0064	
10	H, D	TEST SET, CRYSTAL RECTIFIER TS-268E/U	6625-00-669-1215	
11	H, D	TOOL KIT, ELECTRONIC EQUIPMENT TK-100/G	5180-00-605-0079	
12	H, D	WATTMETER AN/URM-98	6625-00-566-4990	
13	O	TOOLS AND TEST EQUIPMENT AVAILABLE TO REPAIRMAN FOR ASSIGNED MISSION.		

By Order of the Secretary of the Army:

BERNARD W. ROGERS  
General, United States Army  
Chief of Staff

Official:

PAUL T. SMITH  
Major General, United States Army  
The Adjutant General

DISTRIBUTION:

*Active Army:*

USASA (2)	USARMIS (1)	29-27
COE (1)	USAERDAA (1)	29-35
TSG (1)	USAERDAW (1)	29-36
USAARENBD (1)	Sig FLDMS (1)	29-37
DARCOM (1)	Units org under fol TOE: -- I ea	29-51
TECOM (2)	1-55	29-51
USACC (4)	1-56	29-55
TRADOC (2)	1-127	29-56
LOCC (3)	1-137	29-57
OS Maj ClnD (4)	7	29-75
MDW (1)	7-100	29-79
Armies (2)	8-137	29-105
Corps (2)	9-47	29-109
Instl (2) except	9-87	37
Ft CilleM (10)	9-227	37-100
Ft Gordon (10)	11-16	39-51
Ft Huachuca (10)	11-96	39-52
Ft Carson (5)	11-97	44-435
SAAD (30)	11-98	44-436
LBAD (14)	11-117	44-437
TOAD(14)	11-500(AA-AC)	44-445
SHAD (3)	17	44-535
HISA (Ft Monmouth) (33)	17-51	44-536
Ft Richardson (ECOM Ofc) (2)	17-100	44-537
Svc Colleges (1)	29-1	44-545
USAICS (3)	29-15	44-546
USAADS (2)	29-16	44-547
USAFAS (2)	29-17	55-157
USAIS (2)	29-21	57
USAES (2)	29-25	57-100
MAAG (1)	29-26	

ARNG & USAR. None.

For explanation of abbreviations used, see AR 310-50.



TECHNICAL MANUAL  
TEST SET TS-147D/UP

CHANGE }  
No. 1 }

HEADQUARTERS,  
DEPARTMENT OF THE ARMY  
WASHINGTON, D.C., 4 September 1963

TM 11-1247B, May 1956 is changed as follows:

Page 1-1. Add paragraphs 1.1 and 1.2 after paragraph 1.

**1.1. Index of Publications**

Refer to the latest issue of DA Pam 3104 to determine whether there are new editions, changes, or additional publications pertaining to this equipment. DA Pam 310-4 is a current index of technical manuals, technical bulletins, supply bulletins, lubrication orders, and modification work orders available through publications supply channels. The index lists the individual parts (-10, -20, -35P, etc.) and the latest changes to and revisions of equipment publication.

**1.2. Forms and Records**

a. *Reports of Maintenance and Unsatisfactory Equipment.* Use equipment forms and records in accordance with instructions in TM 38-750.

b. *Report of Damaged or Improper Shipment.* Fill out and forward DD Form 6 (Report of Damaged or

Improper Shipment) as prescribed in AR 700-58 (Army), NAVSANDA Publication 378 (Navy), and AFR 71-4 (Air Force).

c. *Reporting of Equipment Manual Improvements.* The direct reporting by the individual user of errors, omissions, and recommendations for improving this manual is authorized and encouraged. DA Form 2028 (Recommended Changes to DA Technical Manual Parts Lists or Supply Manual 7, 8 or 9) will be used for reporting these improvements. This form will be completed in triplicate using pencil, pen, or typewriter. The original and one copy will be forwarded direct to: Commanding Officer, U.S. Army Electronics Materiel Support Agency, ATTN: SELMS-MP, Fort Monmouth, N.J. One information copy will be furnished to the individual's immediate supervisor (e.g., officer, noncommissioned officer, supervisor, etc).

Page 4-19. Add sections 4.1 and 4.2 after section 4.

**SECTION 4.1  
OPERATOR'S MAINTENANCE INSTRUCTIONS**

**1. Scope of Operator's Maintenance**

The maintenance duties assigned to the operator of Test Set TS-147D/UP are listed below together with a reference to the paragraphs covering the specific maintenance function. The duties assigned do not require tools or test equipment other than those issued with the test set.

a. Daily preventive maintenance checks and services (para. 4).

b. Weekly preventive maintenance checks and services (par. 5).

c. Cleaning (para. 6).

Preventive maintenance is the systematic care, servicing, and inspection of equipment to prevent the occurrence of trouble, to reduce downtime, and to assure that the equipment is serviceable.

a. *Systematic Care.* The procedures given in paragraphs 4 through 6 cover routine systematic care and cleaning essential to proper upkeep and operation of the equipment.

b. *Preventive Maintenance Checks and Services.* The preventive maintenance checks and services charts (paras. 4 and 5) outline functions to be performed at specific intervals. These checks and services are to maintain Army electronic equipment in a combat serviceable condition; that is, in good general (physical)

**2. Operator's Preventive Maintenance**

condition and in good operating condition. To assist operators in maintaining combat serviceability, the chart indicates what to check, how to check, and what the normal conditions are. The references column lists the illustrations, paragraphs, or manuals that contain detailed repair or replacement procedures. If the defect cannot be remedied by the operator, higher echelon maintenance or repair is required. Records and reports of these checks and services must be made in accordance with the requirements set forth in TM 38-750.

### 3. Preventive Maintenance Checks and Services Periods

Preventive maintenance checks and services of Test Set TS-147D/UP are required daily and weekly. Paragraph 4 specifies the items to be checked and serviced daily. Paragraph 5 specifies the items to be checked and serviced weekly. In addition to the routine daily and weekly checks and services, the equipment should be rechecked and serviced immediately before going on a mission and as soon after completion of the mission as possible.

#### 4. Daily Preventive Maintenance Checks and Services Chart

SEQ. NO.	ITEM	PROCEDURE	REFERENCES
1	Completeness -----	Check test set for completeness and general condition -----	Sec. 1, para. 2. Sec. 4.1, para. 6.
2	Cleanliness-----	Remove dirt and moisture from exposed surfaces of housing, cabinets, control panel, and meter windows.	
3	Damage -----	Check for damage to glass windows.	Sec. 3, para. 4.
4	Meters -----	While performing the procedure given in item 6, check for sticking pointer movement in meter.	
5	Controls -----	While performing the procedure given in item 6 check controls for binding and scraping. Tap controls gently for cutout due to loose contacts.	
6	Performance -----	While making the performance check, be alert for any unusual performance, response, or condition.	
7	Dial and indicating lamps -----	Check for burned out dial and indicating lamps.	

#### 5. Weekly Preventive Maintenance Checks and Services Chart

SEQ. NO.	ITEM	PROCEDURE	REFERENCES
1	Cables and cords -----	Check cables and cords for cracks, strain, and fraying.	
2	Handles, latches, and hinges.	Check for loosening of handles, latches, and hinges.	
3	Preservation -----	Check exposed metal surfaces for rust and corrosion.	

#### 6. Cleaning

Inspect the exterior of Test Set TS-147D/UP. The exterior surfaces should be clean, and free of dust, dirt, grease, and fungus.

a. Remove dust and loose dirt with a clean soft cloth.

**Warning: Cleaning compound is flammable and its fumes are toxic. Provide adequate ventilation. Do not use near a flame.**

b. Remove grease, fungus, and ground-in dirt from the cases; use a cloth dampened (not wet) with cleaning compound (Federal Stock No. 7930395-9542).

TAGO 10006A

c. Remove dust or dirt from plugs and jacks with a brush.

**Caution: Do not press on the meter face (glass) when cleaning; the meter may become damaged.**

d. Clean the front panels, meters, and control knobs; use a soft clean cloth. If necessary, dampen the cloth with water; mild soap may be used for more effective cleaning.

**SECTION 4.2  
ORGANIZATIONAL MAINTENANCE INSTRUCTIONS**

**1. Scope of Organizational Maintenance**

Second echelon maintenance duties are listed below, together with a reference to the paragraphs covering the specific maintenance functions. The duties assigned do not require tools or test equipment other than those normally available to the repairman user because of his assigned mission. Lubrication is not required for any part of this equipment.

- a. Monthly maintenance (par. 3).
- b. Monthly preventive maintenance checks and services (par. 4).
- c. Cleaning and touchup painting (par. 5).

**2. Organizational Preventive Maintenance**

a. Preventive maintenance is the systematic care, inspection, and servicing of equipment to maintain it in serviceable condition, prevent breakdowns, and assure maximum operation capability. Preventive maintenance is the responsibility of all echelons concerned with the equipment and includes the inspection, testing, and repair or replacement of parts, subassemblies, or units that inspection and tests indicate would probably fail before the next scheduled periodic service. Preventive maintenance checks and services of Test Set TS-

147D/UP at the second echelon level are made at monthly intervals unless otherwise directed by the commanding officer.

- b. Maintenance forms and records to be used and maintained on this equipment are specified in TM 38-750.

**3. Organizational Monthly Maintenance**

Perform the maintenance functions indicated in the monthly preventive maintenance checks and services chart (par. 4) once each month. A month is defined as approximately 30 calendar days of 8-hour-per-day operation. If the equipment is operated 16 hours a day, the monthly preventive maintenance checks and services should be performed at 14-day intervals. Adjustment of the maintenance interval must be made to compensate for any unusual operating conditions. Equipment maintained in a standby (ready for immediate operation) condition must have monthly preventive maintenance checks and services performed on it. Equipment in limited storage (requires service before operation) does not require monthly preventive maintenance.

**4. Monthly Preventive Maintenance Checks and Services Chart**

SEQ. NO.	ITEM	PROCEDURE	REFERENCES
1	Completeness -----	Check test set for completeness and general condition	Page 1-1, para. 2.
2	Spare parts ----- ----- -----	Check all spare parts for general condition and method of storage. There should be no evidence of overstock and all shortages must be on valid requisition.	
3	Modifications ----- ----- -----	Check to determine if new applicable MWO's have been published. All URGENT MWO's must be applied immediately. All NORMAL MWO's must be scheduled.	DA Pam 31-4.
4	Publications ----- -----	Check to see that all publications are complete, serviceable, and current.	DA Pam 3104.
5	Cleanliness ----- -----	Remove dirt and moisture from exposed surfaces of housing, cabinets, control panel, and meter windows.	Sec. 4.1, para. 6.
6	Damage -----	Check for broken glass windows.	
7	Cables, cords -----	Check cables and cords for cracks, strain, and fraying.	
8	Handles, latches, ---- and hinges.	Check for looseness of handles, latches, and hinges.	
9	Preservation ----- -----	Check exposed metal surfaces for rust and corrosion. Clean and touchup paint as required (par. 5).	
10	Fuses, crystals, ----- lamps and ----- connectors. -----	Check seating of front panel, accessible pluck-out items. Do not remove, rock, or twist items; only apply a direct pressure to insure the item is fully seated.	

**Warning:** Always remove the power cord plug from the ac supply source before the chassis is removed from the carrying case. Unless the cord is disconnected, voltage is present even when the switch is off.

**Caution:** Maintenance personnel must at all times avoid disturbing the position or adjustment of any assembly.

SEQ. NO.	ITEM	PROCEDURE	REFERENCES	
11	Resistors and capacitors.	Check resistors and capacitors for cracks, blistering, and discoloration.	Sec. 5, para. 4a.	
12	Bushings, gaskets, insulators, and sleeves.	Check for cracks, chipping or excessive wear.		
13	Capacitors, resistors chokes, and potentiometers.	Check for corrosion, dirt, and loose contacts.		
14	Clean interior	Clean interior of chassis and cabinets.		
15	Terminal blocks	Check for loose connections, cracks, and breaks.		
16	Controls	While performing operational check (item 17), check controls for binding and scraping. Tap controls gently for cutout due to loose contacts.		
17	Performance check	When making performance checks, be alert for any unusual performance, response, or condition.		
				Page 3-2, para. 4.

**5. Touchup Painting Instructions**

Cleaning rust and corrosion from metal surfaces by lightly sanding them with fine sandpaper. Brush two thin coats of paint on the bare metal to protect it from further corrosion. Refer to the applicable cleaning and refinishing practices specified in TM 9-213.

Page 5-1. Make the following changes:

Section heading. Delete "MAINTENANCE" and substitute: FIELD AND DEPOT MAINTENANCE INSTRUCTIONS.

Delete paragraph 1.

Page 6-18. Add the appendix after section 6.

**APPENDIX REFERENCES**

DA Pam 310-4 Index of Technical Manuals, Technical Bulletins, Supply Bulletins, Lubrication Orders, and Modification Work Orders.  
 TM 9-213 Painting Instructions for Field Use.

TM 38-750 The Army Equipment Record System and Procedures.  
 Page 6-1. Delete section 6.

By Order of the Secretary of the Army:

EARLE G. WHEELER,  
General, United States Army,  
Chief of Staff.

Official:

J. C. LAMBERT,  
Major General, United States Army,  
The Adjutant General.

Distribution:

Active Army:

DASA (6)	Army Tml (1)	11-555
USASA (2)	POE (1)	11-557
CNGB (1)	USAOSA ( )	11-587
CofEngrs (1)	AMS (1)	11-592
TSG (1)	WRAMC (1)	11-597
CSigO (7)	AFIP (1)	17
CofT (1)	Army Pic Cen (2)	17-51
CSptS (1)	USA Mbl Spt Cen (1)	29-1
USA CD Agcy (1)	USA Elct Mat Agcy (12)	29-15
USCONARC (5)	Chicago Proc Dist (1)	29-16
USAMC (5)	USARCARIB Sig Agcy (1)	29-17
ARADCOM (2)	Sig Fld Maint Shop (3)	29-21
ARADCOM Rgn (2)	Units org under fol TOE's:	29-25
OS Maj Comd (3)	(2 cy ea)	29-26
OS Base Comd (2)	1-7	29-27
LOGCOMND (2)	1-17	29-35
USAECOM (5)	1-37	29-36
USAMICOM (4)	1-55	2937
USASCC (4)	1-56	29-51
MDW (1)	1-67	29-55
Armies (2)	1-75	29-56
Corps (2)	1-76	29-57
USA Corps (3)	1-107	29-75
USATC AD (2)	1-127	29-79
USATC Engr (2)	1-137	29-105
USATC Inf (2)	7	29-109
USATC Armor (2)	7-100	37
USASTC (5)	8-137	39-51
Instl (2) except	9-47	39-52
Ft Monmouth (63)	9-87	44-435
Svc Colleges (2)	9-227	44-436
Br Svc Sch (2) except	9-377	44-437
GENDEP (OS) (2)	9-500 (AA-AC)	44-445
Sig Dep (OS) (12)	11-5	44-446
Sig Sec, GENDEP (5)	11-6	44-447
Army Dep (2) except	11-7	44-448
Ft Worth (8)	11-16	44-535
Lexington (12)	11-55	44-536
Sacramento (28)	11-56	44-537
Tobyhanna (12)	11-57	44-544
Redstone Arsenal (5)	11-96	44-545
AAF (5)	11-97	44-546
USA Elct RD Actv, White Sands	11-98	44-547
(13)	11-117	44-548
USA Elct RD Actv, Ft Huachuca	11-155	55-157
(2)	11-157	57
USA Trans Tml Comd (1)	11-500 (AA-AC, RM-RU)	
NG: State AG (3); unitanme as Active Army except allowance is one copy to each unit.		
USAR: None.		

For explanation of abbreviations used, see AR 320-50.

TAGO 10096-A

**TEST SET TS-147D/UP**

**SECTION 1 -GENERAL DESCRIPTION**

<i>Paragraph</i>	<i>Page</i>
1. General.....	1-1
2. Physical Description	
a. General.....	1-1
b. Accessories .....	1-2
c. Operating Maintenance Repair Parts.....	1-2
3. Electrical description	
a. General.....	1-3
b. Frequency Modulation Characteristics.....	1-3
c. Average Power Measurements.....	1-3
d. Frequency Measurements.....	1-3
4. Auxiliary Equipment	
a. General.....	1-3
5. Reference Data	
a. Nomenclature .....	1-3
b. Contract Number .....	1-3
c. Contractor.....	1-3
d. Cognizant Naval Inspector .....	1-3
e. Number of Packages Per Complete Shipment.....	1-3
f. Total Cubical Contents.....	1-3
g. Total Weight .....	1-3
h. Signal Generator .....	1-3
i. Frequency Meter .....	1-5
j. RF Power Level Wattmeter .....	1-5
k. Sawtooth Sweep.....	1-5
l. Impedances.....	1-5
m. Power Supply .....	1-5
n. Equipment Similarities.....	1-5
o. Tube Complement.....	1-5

**SECTION 2-THEORY OF OPERATION**

1. Principles of Operation	
a. General.....	2-1
b. Oscillator Output.....	2-1
c. Power Measurements .....	2-1
d. Frequency Measurements of Output Signals .....	2-2
e. Frequency Measurements of Input Signals.....	2-2
2. RF Plumbing Components	
a. General.....	2-2
b. Tube Mount Assembly.....	2-2
c. Frequency Meter Assembly.....	2-3
d. Thermistor Mount Assembly.....	2-3
e. Attenuators .....	2-4
f. Attenuation .....	2-4
g. RF Output and Detector Section .....	2-6
3. Electrical Circuits	
a. General.....	2-6
b. Trigger Detector and Amplifier Circuit .....	2-6

<i>Paragraph</i>	<i>Page</i>
c. Blocking Oscillator Sweep and External Modulation Circuit .....	2-7
d. Oscillator Circuit.....	2-8
e. Thermistor Bridge Wattmeter Circuit	
(1) General .....	2-10
(2) Basic Bridge Circuit.....	2-10
(3) Sensitivity Compensation.....	2-11
(4) DC Voltage Compensation.....	2-11
(5) Compensated Bridge Circuit .....	2-11
(6) High Sensitivity.....	2-12
f. Power Supply Circuits.....	2-12

**SECTION 3-INSTALLATION**

1. Unpacking .....	3-1
2. Installation	
a. Inspection.....	3-1
b. Preinstallation Test.....	3-1
c. Location.....	3-2
d. Outline Dimensions .....	3-2
3. Initial Adjustments .....	3-2
4. Performance Check .....	3-2

**SECTION 4-OPERATION**

1. Introduction	
a. General .....	4-1
b. Tests and Formulas .....	4-1
2. Oscilloscope	
a. General .....	4-2
b. Preliminary Connections and Adjust- ments .....	4-2
3. Radar Set-Preliminary Connections and Adjustments .....	4-2
4. Test Set TS-147D/UP-General Operating Instructions .....	4-2
a. General .....	4-2
b. Measuring Power with the Thermistor Bridge Wattmeter .....	4-2
c. Tuning the Test Set Oscillator.....	4-3
d. DBM Attenuator Calibration Chart.....	4-3
e. RF Connecting Cord CG-92A/U(8').....	4-3
5. Preliminary Connections and Adjustments	
a. Connections .....	4-4
b. FM Operation-Tuning the Test Set to the Receiver .....	4-4
c. General Operating Procedure .....	4-4
6. Test 1A-Transmitter Average Power, P <sub>v</sub> Above - 10 DBM .....	4-4
7. Test 1B-Transmitter Average Power, P <sub>a</sub> , Below + 10 DBM.....	4-9
8. Test 2-Transmitter Frequency, f <sub>t</sub> .....	4-9
9. Test 3-Receiver Frequency, f <sub>r</sub> .....	4-9

**Contents**

<i>Paragraph</i>	<i>Page</i>
10. Test 4-Receiver Bandwidth Measurement.....	4-10
11. Test 5-Receiver Performance Figure, Pm (Sensitivity), Using FM .....	4-11
12. Test 6-CW Signal Equal to Noise .....	4-11
13. Test 7A-TR Recovery Time, Using FM .....	4-12
14. Test 7B-TR Recovery Time, Using CW .....	4-12
15. Test 8-Transmitter Pulling and AFC Tracking .....	4-13
16. Test 9-Beacon Response of Radar .....	4-13
17. Synthetic Target.....	4-13
18. Radar Receiver Tuning, Using FM.....	4-13
19. Space Loss with Pick-up Antenna .....	4-15
20. Pulse Analyzer .....	4-15
21. External Modulation .....	4-15
22. Formula 1-Transmitter Average Power, Pav.....	4-17
23. Formula 2-Receiver Performance, Pm .....	4-17
24. Computing the Transmitter Performance Figure.....	4-17
25. Computing Rated Transmitter Average Power in DBM.....	4-18
26. Computing the Radar Overall Performance Figure S .....	4-18
27. Change in Overall Performance .....	4-18

**SECTION 5-MAINTENANCE**

1. Operator's Maintenance.....	5-1
2. Preventive Maintenance	
a. General .....	5-1
b. Semiannual Inspection.....	5-1

<i>Paragraph</i>	<i>Page</i>
c. Lubrication.....	5-1
3. Corrective Maintenance, General.....	5-1
4. Removal of Units .....	5-1
5. RF Plumbing	
a. General .....	5-2
b. Removing and Replacing Assemblies	
(1) Front Panel.....	5-5
(2) RF Output and Detector Section ...	5-5
(3) DBM Calibrated Attenuator .....	5-5
(4) Frequency Meter .....	5-6
6. Operating Maintenance Repair Parts	
a. General .....	5-6
b. Gaskets .....	5-6
c. Thermistor Mount Assembly .....	5-6
d. Fuses .....	5-7
e. Crystals .....	5-7
f. Dial Lamps .....	5-7
7. Tube Information	
a. General .....	5-7
b. Klystron Oscillator Tube (V104) .....	5-7
8. Adjustments	
a. General .....	5-8
b. Set Zero-Coarse Potentiometer (R124) ..	5-8
c. Sweep Adjust Potentiometer (R142).....	5-8
9. Calibration of Attenuation of Cord CG-92A/U(8').....	5-9
10. Troubles and Remedies, Test Set TS-147D/UP .....	5-9

**SECTION 6-PARTS LISTS**

**ORIGINAL**

## LIST OF ILLUSTRATIONS

## SECTION 1-GENERAL DESCRIPTION

<i>Figure</i>	<i>Title</i>	<i>Page</i>
1-1	Test Set TS-147D/UP Complete Equipment .....	1-0
1-2	Test Set TS-147D/UP Stowed for Carrying.....	1-2
1-3	Test Set Accessories .....	1-2

## SECTION 2-THEORY OF OPERATION

2-1	Block Diagram of Test Set TS-147D/UP .....	2-0
2-2	RF Plumbing Arrangement .....	2-1
2-3	Simplified Block Diagram Showing Plumbing Branches .....	2-2
2-4	Gasket-Flange Joint .....	2-2
2-5	Choke-Flange Joint .....	2-2
2-6	Tube Mount Assembly, Simplified Phantom View .....	2-3
2-7	Tube Mount Assembly .....	2-3
2-8	Frequency Meter Assembly .....	2-4
2-9	Frequency Meter Assembly, Simplified Phantom View .....	2-4
2-10	Thermistor Mount .....	2-4
2-11	Thermistor Mount, Simplified Phantom View .....	2-5
2-12	DBM Calibrated Attenuator.....	2-5
2-13	DBM Calibrated Attenuator, Simplified Phantom View .....	2-5
2-14	Step Attenuator.....	2-5
2-15	Step Attenuator, Simplified Phantom View....	2-6
2-16	RF Output and Detector Section .....	2-6
2-17	Trigger-Detector and Amplifier Circuit, Simplified Schematic.....	2-6
2-18	Blocking Oscillator Sweep and External Modulation Circuit.....	2-7
2-19	Test Oscillator Circuit .....	2-8
2-20	Test Oscillator Tube Cut-away View.....	2-8
2-21	Reflex Klystron Characteristics.....	2-9
2-22	Test Oscillator Modulation .....	2-9
2-23	Bead Thermistor .....	2-10
2-24	Disc Thermistor .....	2-10
2-25	Basic Thermistor Bridge Circuit .....	2-10
2-26	Thermistor Bridge Circuit Showing Sensitivity Compensation.....	2-11
2-27	Thermistor Bridge Circuit Showing Voltage Compensation .....	2-11
2-28	Complete Thermistor Bridge Circuit .....	2-11

## SECTION 3-INSTALLATION

3-1	Primary Power Distribution Diagram.....	3-1
3-2	Preinstallation Check Diagram .....	3-1
3-3	Test Set TS-147D/UP Outline Dimensional Drawing.....	3-3

## SECTION 4-OPERATION

<i>Figure</i>	<i>Title</i>	<i>Page</i>
4-1	Test Set TS-147D/UP .....	4-0
4-2	Typical Calibration Chart.....	4-3
4-3	Operating Connection Diagram.....	4-4
4-4	Simplified Procedure for Operating Test Set TS-147D/UP as a Frequency Measuring Device .....	4-6
4-5	Simplified Procedure for Operating Test Set TS-147D/UP as a Power Measuring Device .....	4-6
4-6	Simplified Procedure for Operating Test Set TS-147D/UP as a CW Signal Generator ...	4-7
4-7	Simplified Procedure for Operating Test Set TS-147D/UP as a FM Signal Generator ....	4-7
4-8	Simplified Procedure for Operating Test Set TS-147D/UP as a Pulsed Signal Generator.....	4-8
4-9	Frequency Modulated Test Set Signals .....	4-8
4-10	Receiver Frequency and Bandwidth Measurements .....	4-10
4-11	Measuring Minimum Discernible Signal Power .....	4-11
4-12	Receiver Tuning on CW and Alternate Method of Checking TR Recovery .....	4-12
4-13	Checking Receiver Pulling and AFC Tracking .....	4-13
4-14	CW Jamming .....	4-13
4-15	Sample Radar Performance Data Sheet.....	4-14
4-16	Frequency Meter Correction for Dielectric Changes Due to Temperature and Humidity .....	4-16
4-17	Frequency Meter Corrections for Dimensional Changes Due to Temperature .....	4-17
4-18	DBM to Watts Conversion Chart .....	4-18
4-19	Average to Peak Power Conversion Chart .....	4-19

## SECTION 5-MAINTENANCE

5-1	Failure Report, Sample Form.....	5-0
5-2	Test Set Chassis Rear View.....	5-2
5-3	Video Amplifier Sub-Assembly, Bottom View .....	5-3
5-4	Video Amplifier Sub-Assembly, Top View .....	5-3
5-5	Assembled Wave Guide, Front View .....	5-4
5-6	Assembled Wave Guide, Rear View .....	5-4
5-7	Test Set Chassis Bottom-Rear View.....	5-12
5-8	Test Set Chassis Right End View.....	5-13
5-9	Test Set Chassis Top Rear View .....	5-14
5-10	Test Set Chassis Bottom-Front View .....	5-15
5-11	Test Set Front Panel View.....	5-16



**FRONT MATTER**

**Illustrations and Tables**

<i>Figure</i>	<i>Title</i>	<i>Page</i>
5-12	Power Supply Chassis and Control Panel Wiring Diagram .....	5-17
5-13	Video Amplifier Sub-Assembly, Practical Wiring Diagram .....	5-19

<i>Figure</i>	<i>Title</i>	<i>Page</i>
5-14	Cord CG-92A/U(8'), Fabrication Notes.....	5-20
5-15	Assembly of BNC Type Connectors.....	5-21
5-16	Test Set TS-147D/UP Complete System Schematic .....	5-23

**LIST OF TABLES**

**SECTION 1-GENERAL DESCRIPTION**

<i>Table</i>	<i>Title</i>	<i>Page</i>
1-1	Equipment Supplied.....	1-1
1-2	Equipment and Publications Required But Not Supplied.....	1-2
1-3	Shipping Data .....	1-3
1-4	Basic Differences In TS-147/UP Series Equipment .....	1-4
1-5	Tube and Crystal Complement.....	1-5

**SECTION 4-OPERATION**

4-1	List of Tests and Formulas .....	4-1
4-2	Function of Controls and Connectors .....	4-5

**SECTION 5-MAINTENANCE**

5-1	Rated Tube Characteristics .....	5-6
5-2	DC Resistance Chart.....	5-7

**ORIGINAL**

<i>Table</i>	<i>Title</i>	<i>Page</i>
5-3	DC Voltage Chart .....	5-8
5-4	Test Set TS-147D/UP Troubles and Remedies .....	5-10
5-5	Winding Data .....	5-11

**SECTION 6-PARTS LISTS**

6-1	Weights and Dimensions of Spare Parts Boxes .....	6-1
6-2	Shipping Weights and Dimensions of Spare Parts Boxes .....	6-1
6-3	List of Major Units.....	6-1
6-4	Table of Replaceable Parts .....	6-2
6-5	Cross Reference Parts List .....	6-16
6-6	Applicable Color Codes and Miscellaneous Data.....	6-17
6-7	List of Manufacturers.....	6-18

**SAFETY NOTICE**

casualties always remove power and discharge and ground circuits prior to touching them.

**DON'T SERVICE OR ADJUST ALONE:**

Under no circumstances should any person reach within or enter the enclosure for the purpose of servicing or adjusting the equipment without the immediate presence or assistance of another person capable of rendering aid.

**DON'T TAMPER WITH INTERLOCKS:**

Do not depend upon door switches or interlocks for protection but always shut down motor generators or other power equipment. Under no circumstances should any access gate, door, or safety interlock switch be removed, short-circuited, or tampered with in any way, by other than authorized maintenance personnel, nor should reliance be placed upon the interlock switches for removing voltages from the equipment.

This equipment employs voltages which are dangerous and may be fatal if contacted by operating personnel. Extreme caution should be exercised when working with the equipment.

While every practicable safety precaution has been incorporated in this equipment, the following rules must be strictly observed:

**KEEP AWAY FROM LIVE CIRCUITS:**

Operating personnel must at all times observe all safety regulations. Do not change tubes or make adjustments inside equipment with high voltage supply on. Under certain conditions dangerous potentials may exist in circuits with power controls in the OFF position due to charges retained by capacitors. To avoid

**WARNING**

**THE HIGH VOLTAGES USED IN THIS EQUIPMENT ARE DANGEROUS TO LIFE. OBSERVE ALL SAFETY REGULATIONS. NEVER MEASURE POTENTIALS IN EXCESS OF 1000 VOLTS BY MEANS OF FLEXIBLE TEST LEADS OR PROBES.**

**RESUSCITATION**

**AN APPROVED POSTER ILLUSTRATING THE RULES FOR RESUSCITATION BY THE PRONE PRESSURE METHOD SHALL BE PROMINENTLY DISPLAYED IN EACH RADIO, RADAR, OR SONAR ENCLOSURE. POSTERS MAY BE OBTAINED UPON REQUEST TO THE BUREAU OF MEDICINE AND SURGERY.**

ORIGINAL

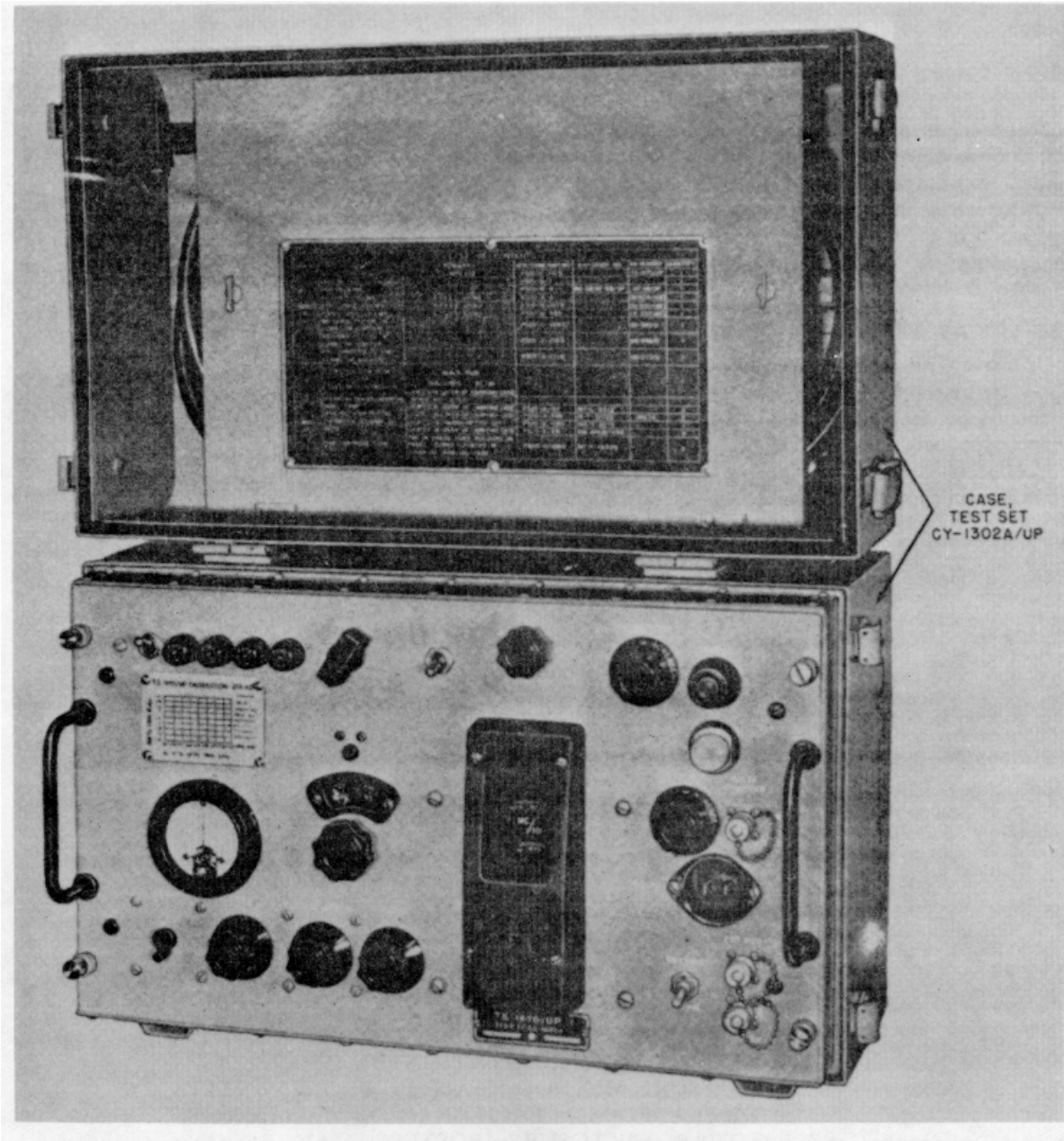

Figure 1-1. Test Set TS-147D/UP Complete Equipment

ORIGINAL

SECTION 1  
GENERAL DESCRIPTION

1. GENERAL.

(See figure 1-1.) (See table 1-1.)

a. Test Set TS-147D/UP is a portable microwave signal generator. It is used for testing and adjusting beacon equipment and radar systems that operate within the band of 8500 to 9600 mc. The set measures the power and frequency of external pulsed and continuous wave signals and supplies output signals that are continuous wave (CW) or frequency modulated (FM). The test set has a provision to allow for external

modulation to produce a pulsed RF signal. A connector is provided so that the envelope of an RF pulse applied to the test set can be observed on an oscilloscope.

b. Power measurements are made by means of a calibrated RF attenuator and a thermistor bridge type wattmeter. The attenuator reduces the incoming power to a standard level of one milliwatt. The amount of attenuation is read from a DBM dial. The original incoming power is then calculated from this reading. No auxiliary equipments are required for making this

TABLE 1-1. EQUIPMENT SUPPLIED

QUAN PER EQUIP.	NAME OF UNIT	NOMENCLATURE	OVER-ALL DIMENSIONS			VOLUME	WEIGHT
			HEIGHT	WIDTH	DEPTH		
1	Test Set	TS-147D/UP	13.0	11.8		1.6	47*
			as stored for carrying				
1	Pick-up Antenna*	AT-68/UP	4.5	6.8	2.3	-	0.3
1	RF Cable Assembly*	CG-530/U(6')	Six foot long-			-	0.7
1	Cord*	CG-92A/U(8')	Eight foot long*			-	1
1	Cord*	CX-337/U(6')	Six foot long-			-	0.5
1	Adapter*	UG-273/U	-	-	-	-	0.2
1	Adapter Connector*	UG-397/U	-	-	-	-	0.2
1	Adapter Connector*	UG-446/U	-	-	-	-	0.2
2	Instruction Book***	NAVSHIPS 91716	-	-	-	-	-

\* Packed in test set cover.

\*\* Total weight including accessories.

\*\*\* One of the two books is packed in test set cover.

Dimensions are in inches, volume in cubic feet, weight in pounds.

type of measurement. For outgoing RF signals, the internally generated signals are adjusted to a level of one milliwatt and any desired power level from -7 dbm to -85 dbm can be delivered at the RF connector.

c. Frequency measurements are made through a precision frequency meter, frequency being read on a calibrated dial. The calibration readings are at one megacycle intervals.

d. The frequency modulated (FM) output is normally used with an oscilloscope or a synchroscope (See table 1-2.) which has a provision for a triggered start-stop sweep circuit known as "A" scan (such as Oscilloscope TS-34/AP Series, for testing radar systems). The sweep of the test set and the horizontal sweep of the oscilloscope are triggered in synchronism ORIGINAL with the firing cycle of the radar system. The

resulting patterns seen on the oscilloscope represent frequency response curves of the equipment under test.

e. The unmodulated continuous wave (CW) output is used generally for making receiver sensitivity measurements.

2. PHYSICAL DESCRIPTION.

(See table 1-1.)

a. GENERAL.-The RF plumbing components and electrical circuits of the test set are mounted in a case together with the control panel. A cover, which protects the panel on the case when the set is stowed for carrying, provides for packing the accessories and some of the operating maintenance repair parts. This cover can be removed from the case when the test set is in

1 Section  
Paragraph 2 a

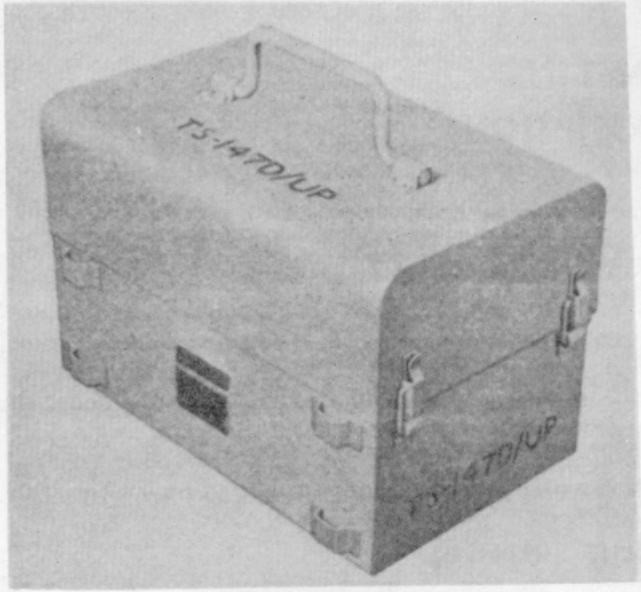

Figure 1-2. Test Set TS-147D/UP Slowed for Carrying

operation. The cover has a carrying handle and the panel has two handles to aid in pulling it and the chassis out of the case.

b. ACCESSORIES.

(1) PICK-UP ANTENNA AT-68/UP (Z101.)The pick-up antenna is a small directive antenna horn that is used in the absence of a directional coupler. It is used to receive externally generated RF energy and to transmit RF signals generated by the test set. The pick-up antenna is connected to the RF connector on the panel of the test set through cord CG-92A/U (8') (W101).

(2) RF CABLE ASSEMBLY CG-530/U (6') (W102).-This cable is used to connect the test set to a trigger source for synchronization when RF pulses are not used. It consists of six feet of RG-62/U cable fitted with an Army-Navy type UG-260/U connector on each end.

(3) CORD CG-92A/U (8') (W101).-This cord is used to make the JRF connection between the test set and the equipment under test. The attenuation of each cord is marked on a metal tag around the RG-9A/U cable which has a UG-21B/U male plug on each end.

(4) CORD CX-337/U (6') (W103).-This cord is used to connect the test set to a source of 115v AC

connector at one end and a male connector at the other. The female connector attaches to the test set and the male connector attaches to a standard convenience outlet or two-prong wall-type receptacle.

(5) ADAPTER CONNECTORS (E123 and E124).-Two wave guide to N coaxial adapters are supplied with the test set. One is adapter connector UG-446/U which adapts from a UG-39/U cover flange (u/w RG-52/U wave guide). The other is adapter connector UG-397/U which adapts from a UG-52A/U cover flange (u/w RG-51/U wave guide).

(6) ADAPTER CONNECTOR (E125).-One BNC to UHF coaxial adapter is supplied with the test set. It is adapter UG-273/U.

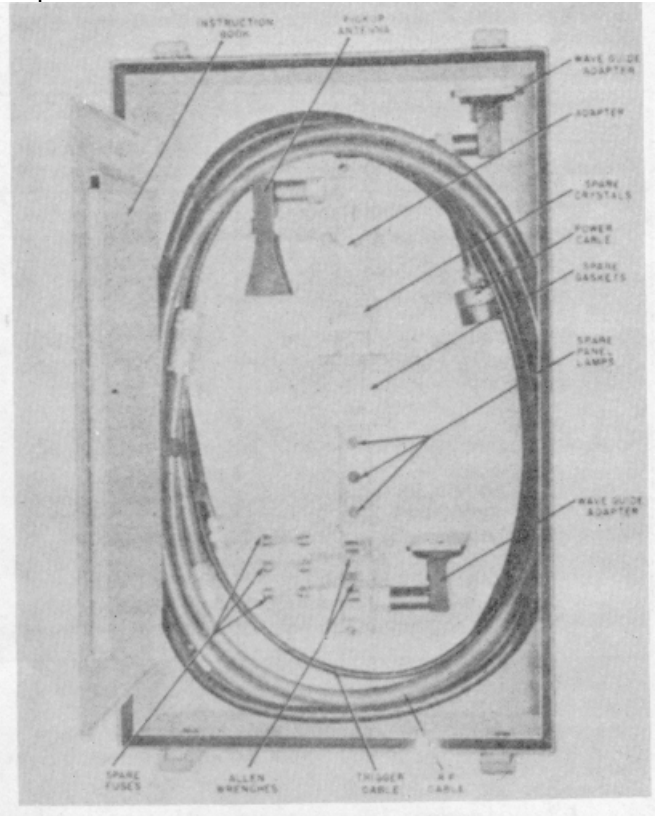

Figure 1-3. Test Set Accessories

c. OPERATING MAINTENANCE REPAIR PARTS.

(1) THERMISTOR MOUNT ASSEMBLY. Provision is made for mounting a spare calibrated

TABLE 1-2. EQUIPMENT AND PUBLICATIONS REQUIRED AND NOT SUPPLIED

QUAN. PER EQUIP.	NAME OF UNIT	NAVY TYPE DESIGNATION	REQUIRED USE	REQUIRED CHARACTERISTICS
1	Oscilloscope or Synchroscope	TS-34/AP Series or equivalent	Alignment and bandwidth measurement	Start-stop sweep circuit ("A" scan)

**GENERAL DESCRIPTION**

thermistor mount assembly, complete with bead and disc thermistor, on the inside of the chassis of Test Set TS-147D/UP.

(2) FUSES.-Two three-ampere fuses are mounted in panel holders marked SPARES. Provision is made for mounting three others in the test set cover.

(3) OTHER PARTS.-Provision is made in the test set cover for mounting the following:

(a) LAMPS.--1 three 3.0 volt lamps.

(b) GASKETS.--Nine gaskets for use in wave guide flange joints.

(c) CRYSTALS.--Two type IN23A silicon rectifier crystals.

**3. ELECTRICAL DESCRIPTION.**

a. GENERAL.-Test Set TS-147D1/UP is essentially a microwave signal generator, power mastering device, and frequency measuring device. The signal generator is a reflex klystron (2K25). It can operate at continuous wave or it can be frequency modulated. There is also a provision for modulating the reflex klystron from an external pulse source.

b. FREQUENCY MODULATION CHARACTERISTICS.-Frequency modulation is produced by applying a sawtooth sweep, to the reflex klystron. The amplitude (and slope) of the sawtooth can be continuously varied to give frequency excursions over a range of zero (CW) to over 40 mc.

c. AVERAGE POWER MEASUREMENTS.-Average power measurements are made by a temperature compensated thermistor bridge type wattmeter and a calibrated RF attenuator. The test set can measure the power level both of the test signals generated within the instrument and of external signals supplied to the test set. Power is measured in dbm (decibels above or below one milliwatt). The ranges of --42 to --85 dbm and from -7 to -45 dbm are for test signals supplied by the test set. The range of +7 to +30 dbm is for external power supplied to the test set. The accuracy of these measurements is within 1.5db. The calibration given is at the point of the RF connector and the attenuation of the cords and coupling devices must be added to these values.

d. FREQUENCY MEASUREMENTS-Frequency measurements are made by an absorption frequency meter that uses the thermistor bridge wattmeter as a tuning indicator. When tuned to resonance, the frequency meter absorbs part of the power so that a dip Section 1 Paragraph 2 c (1) in the indication is observed.

The range of the frequency meter is 8470 to 9630 mc. The accuracy is within 2.5 mc. over this range. The frequency difference between any two signals not more than 60 mc apart can be measured to within 1.0 mc. At 9310 mc, the frequency meter accuracy is calibrated to within 1.0 mc. Energy generated within the test set or applied externally can be measured.

**4. AUXILIARY EQUIPMENT.**

a. GENERAL.-Although a radar system indicator may be used for display, a separate oscilloscope is preferable in most cases and is a requirement for the measurement of bandwidth and recovery time. For this purpose, an oscilloscope with an "A" scan or synchroscope such as Oscilloscope TS-34/AP Series or its equivalent may be used. Also, if the equipment under test is not equipped with a directional coupler, Directional Couplers CU-205/U, CU-206/U, or CG176/AP, or an equivalent must be used when making quantitative measurements.

**5. REFERENCE DATA.**

a. NOMENCLATURE.

(1) Test Set TS-147D/UP;

(2) Pick-up Antenna AT-68/UP.

b. CONTRACT NUMBERS.-NObsr 52607, Dated 25 June, 1951; NObsr 57567, Dated 30 June, 1952.

c. CONTRACTOR.-General Communication Company, 681 Beacon Street, Boston 15, Massachusetts.

d. COGNIZANT NAVAL INSPECTOR.-Inspector of Naval Material, Boston 10, Massachusetts.

e. NUMBER OF PACKAGES PER COMPLETE SHIPMENT. - One. (See table 1-3.)

f. TOTAL CUBICAL CONTENTS. - Unpacked, 1.6 cu ft. Packed for shipment, 3.7 cu ft.

g. TOTAL WEIGHT. - Unpacked, 47 lb. Packed for shipment, 76 lb.

h. SIGNAL GENERATOR

(1) FREQUENCY RANGE.-8500 to 9600 mc.

(2) TUNING BAND.-One continuous.

(3) FREQUENCY CONTROL. - Mechanically tuned resonant cavity.

(4) TYPES OF EMISSION AND MODULATION CAPABILITY.

(a) Frequency Modulation:

1. Center Frequency Range: 8500 to 9600 mc.

*TABLE 1-3. SHIPPING DATA*

SHIPPING BOX NUMBER	CONTENTS		OVERALL DIMENSIONS			VOLUME	WEIGHT
	NAME	DESIGNATION	HEIGHT	WIDTH	DEPTH		
1	Test Set	TS-147D/UP	15.5	24.3	17	3.7	76

Dimensions are in inches, volume in cubic feet, weight in pounds.

**ORIGINAL**

**1 Section**  
**Paragraph 5 h (4) (a) 2**

**GENERAL DESCRIPTION**

2. Sweep Rate: Variable from zero through 6 mc/u sec.
3. Frequency Excursion of Sweep: Zero to over 40 mc.
4. Phase Range: 3 to 50 u sec after trigger.
5. Reflector Voltage Sweep: Can cover three modes.
6. Trigger Pulses required for Sawtooth Sweep Generator:
  - a. Pulse Repetition Rate: To 4000 pps.
  - b. RF Trigger: 5 to 500 watts peak,

- 0.2 to 6.0 u sec duration, rise time less than 0.5 u sec.
- c. Video Trigger: Positive polarity, 10 to 50 volts, 0.5 to 20 u sec duration at 10% maximum amplitude, less than 0.5 u sec rise time between 10% and 90% maximum amplitude points.
    - (b) Continuous Wave: 8500 mc to 9600 mc (no modulation).
    - (c) External Modulation: Capable of being frequency or pulse modulated from an external modulating-source. Amplitude controlled from front panel MOD AMP control.

TABLE 1-4. BASIC DIFFERENCES IN TS-147/UP SERIES EQUIPMENT

CHARACTERISTIC	TS-147/UP	TS-147A/UP	TS-147B/UP	TS-147C/UP	TS-147D/UP
Primary Power	115vAC $\pm$ 10% 50--1200 cps	115vAC $\pm$ 10% 50-1600 cps	115vAC $\pm$ 10% 50--1600 cps	115vAC $\pm$ 10% 50-1600 cps	115vAC $\pm$ 10v 50-1600 cps
Pulse Repetition Rates (FM sweeps)	to 3000 pps	to 3000 pps	to 4000 pps	to 3000 pps	to 4000 pps
Input trigger duration requirement	0.5 to 6 usec	0.5 to 6 usec	0.2 to 6 usec	0-6 usec	0.2 to 6 usec
RF Power Level, input	+7 to +30 dbm $\pm$ 2.0 db	+7 to +30 dbm $\pm$ 2.0 db	+7 to +30 dbm $\pm$ 1.5 db	+7 to +30 dbm $\pm$ 2.0 db	+7 to +30 dbm $\pm$ 1.5 db
RF Power Level, output	-40 to 80 dbm $\pm$ 2.0 db	-7 to -80 dbm $\pm$ 2.0 db	-42 to -85 dbm $\pm$ 1.5 db	-42 to -83 dbm $\pm$ 2.0 db	-7 to -85 dbm $\pm$ 1.5 db
Pulse Analyzer Connector	no	no	yes	no	yes
Capable of being externally modulated	no	no	yes	no	yes
Calibration Curves Mounted on	cover	cover	panel	cover	panel
Thermistor Bridge Circuit	-	-	one disc thermistor - eliminated	-	Switch added to change circuit for about a 4 times increase in sensitivity for measurement of short pulses
Frequency Meter			Friction slow motion drive in addition to regular drive		3:1 step down in regular drive by addition of gears
Chassis	Framed across back only	Framed across top and back	Framed across back only	Framed across top and back	Framed across top and back
Operating Spares	1 Thermistor Mount 5 Fuses 9 Gaskets 3 Lamps 2 Crystals	Same as TS-147/UP	Same as TS-147/UP	Same as TS-147/UP	Provision for same as TS-147/UP
Coarse Thermistor Adjust Control Located on	rear of chassis	rear of chassis	rear of chassis	front panel	front panel

NOTE: Some symbol designations are different for each model.

ORIGINAL

**GENERAL DESCRIPTION**

- (5) RF POWER OUTPUT.
  - (a) Red-Dot Position of TEST Switch: -7 to -45 dbm at RF connector.
  - (b) RECV Position of TEST Switch: -42 to -85 dbm at RF connector.

- i. FREQUENCY METER.
  - (1) RANGE.-8470 mc to 9630 mc.
  - (2) ACCURACY  $\pm 2.5$  mc at 250C (770F) and 60% relative humidity.
  - (3) INCREMENTAL ACCURACY.  $\pm 1.0$  mc for frequency increments of less than 60 mc.
  - (4) CALIBRATION POINT.-9310 mc  $\pm 1$  mc at 250C (770F) and 60% relative humidity.

- j. RF POWER LEVEL WATTMETER.
  - (1) INPUT SIGNALS.-( Average power level in dbm-dbm above 1 mw.)
    - (a) Range: +7 to +30 dbm continuously at RF connector.
    - (b) Accuracy:  $\pm 1.5$  db (with chart).
  - (2) OUTPUT TEST SIGNAL. (Peak Mode power.)-(Average power level in dbm-b below 1 mw.)
    - (a) Range: -7 to -45 dbm and -42 to -85 dbm at RF connector.
    - (b) Accuracy:  $\pm 1.5$  db.

**NOTE**

**THE ACCURACY OF POWER MEASUREMENTS DEPENDS UPON THE CALIBRATION OF THE DIRECTIONAL COUPLER AND THE RF CORD LOSSES. THE TOLERANCES HERE GIVEN ARE BASED ON THE USE OF THE INDIVIDUAL CALIBRATION CHART PROVIDED WITH EACH TEST SET.**

- k. SAWTOOTH SWEEP.
  - (1) AMPLITUDE.-Zero to -100 volts (negative polarity).
  - (2) SLOPE.-Zero to +2.0 volts/u sec (positive slope).
  - (3) DC LEVEL AT OSCILLATOR REFLECTOR. -From -60 to -210 volts.

- (4) TRIGGER AMPLIFIER VOLTAGE GAIN. - Approximately 500.

- l. IMPEDANCES.
  - (1) TRIGGER INPUT.-Over 10,000 ohms.
  - (2) RF OUTPUT AT CONNECTOR.- Nominally 50 ohms over test frequency range of 8500 mc to 9600 mc.

- m. POWER SUPPLY.
  - (1) Integral part of test set, no special type otr number.
  - (2) SUPPLY VOLTAGE.-115 volts AC  $\pm 10$  volts.
  - (3) FREQUENCY.-59 to 1600 cps, single phase.
  - (4) POWER INPUT.
    - (a) Operating: 125 watts, approximately.
    - (b) Standby: 25 watts, approximately (cabinet heater).

- (5) OUTPUT VOLTAGES.
  - (a) Maximum AC voltage at power transformer T101 and rectifier socket X101 is 1700 volts.
  - (b) Plate supply to regulator tube V102 is approximately +600 volts DC.
  - (c) Outer shell of V104 oscillator tube is at +300 volts DC. This tube is contained within a grounded tube shield. Do not remove this shield with the power turned on.
  - (d) Reflector of V104 oscillator tube is at from -60 to -210 volts.
  - (e) Normal operating plate voltages for remaining tubes are either at +300 volts or -210 volts DC.
  - (f) Ripple: Less than 0.1% of peak DC level.

- n. EQUIPMENT SIMILARITIES.-Equipment similarities are described in table 1-4.

- o. TUBE COMPLEMENT.-The electronic tubes used in Test Set TS-147D/UP are listed in table 1-5.

*TABLE 1-5. TUBE AND CRYSTAL COMPLEMENT*

UNIT	NUMBER OF TUBES OR CRYSTALS OF TYPE INDICATED							TOTAL NO. OF TUBES AND CRYSTALS
	OC3/VR105	1N23A	2K25	SR4GY	6SH7	6SL7GT	6Y6G	
Test Set TS-147D/UP	2	1	1	1	1	2	1	9

**ORIGINAL**



2 Section

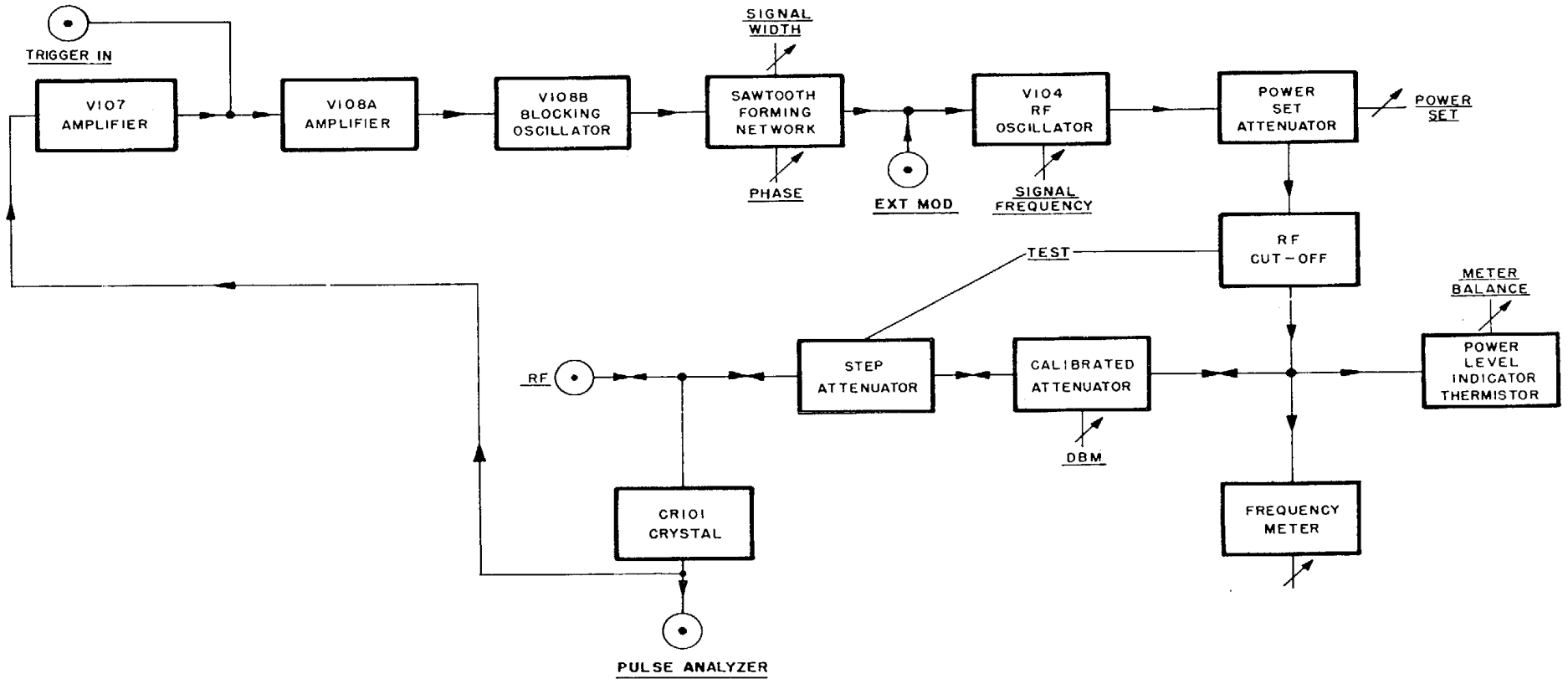

Figure 2-1. Block Diagram of Test Set TS-147D/UP

SECTION 2  
THEORY OF OPERATION

## 1. PRINCIPLES OF OPERATION.

a. GENERAL. --A block diagram of Test Set TS147D/UP is given in figure 2-1. The output signals are generated by the reflex klystron oscillator. They are either frequency modulated by the sawtooth voltages supplied by the triggered sweep circuit, or pulse modulated by the voltages supplied by an external pulse circuit. When the signals are frequently modulated, synchronism is obtained through one of two methods: by supplying trigger voltages at the TRIGGER connector, or by the RF pulses detected by the crystal detector and amplified by the trigger amplifier.

b. OSCILLATOR OUTPUT.-The output power of the klystron oscillator is controlled directly by the POWER SET attenuator and the RF cut-off switch. The POWER SET attenuator permits adjustment of the level applied to the thermistor bridge. The RF cut-off switch is a wave guide mechanism that permits the energy to pass through into the wave guide (open) or completely closes the opening to the wave guide and prevents the energy from entering it.

## c. POWER MEASUREMENTS.

(1) The test set can measure RF power at the RF connector from +7 dbm to +30 dbm (1 watt) average and from -7 dbm to -85 dbm average. This is accomplished by means of two attenuators and a thermistor bridge wattmeter circuit.

(2) The range of +7 to +30 dbm is for RF signals applied to the test set and the range of -7 to -85 dbm is for signals supplied by the test set.

(3) The thermistor bridge circuit is designed to read a reference power level (1 milliwatt) and the two attenuators are calibrated. Therefore, by reducing an unknown incoming RF signal power to one mw by means of the calibrated attenuators the power input at the RF connector can be calculated.

(4) Similarly the power output from the klystron oscillator to the attenuator and the thermistor bridge

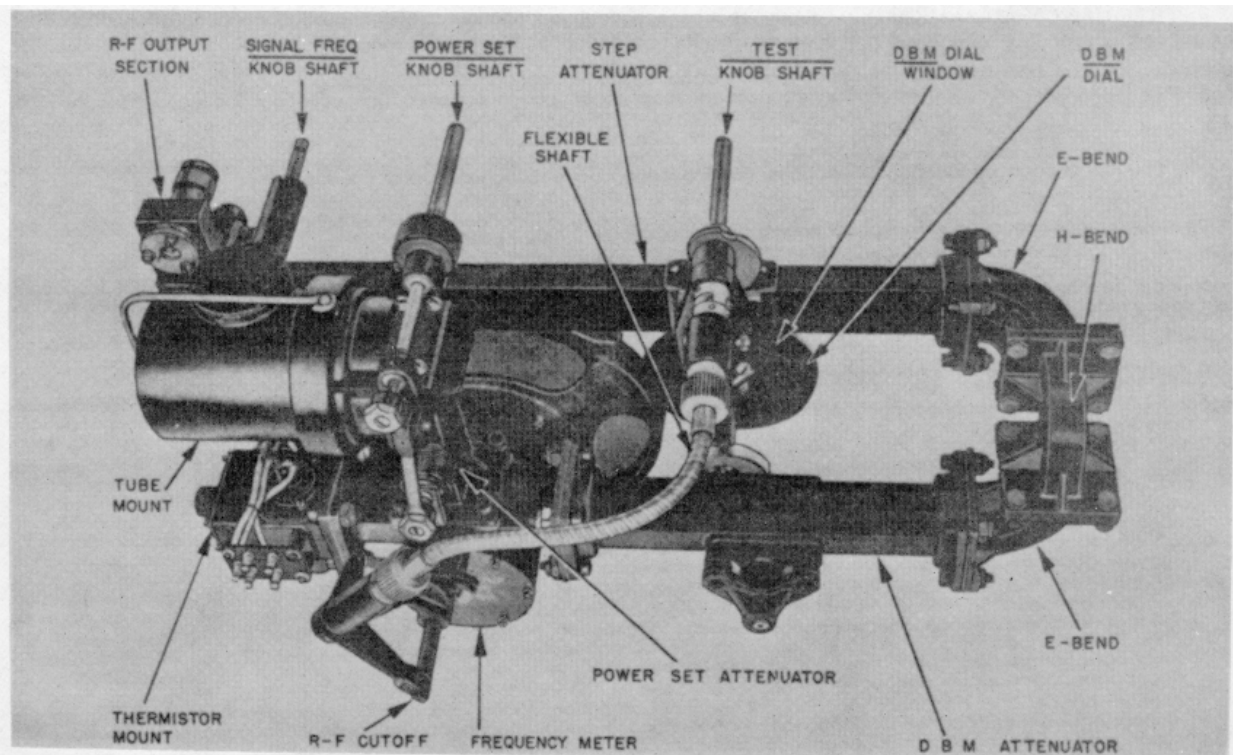

Figure 2-2. RF Plumbing Arrangement

ORIGINAL

circuit can be adjusted to one mw. The attenuation from that point to the RF connector is then determined from the setting of the TEST Switch and the DBM attenuator.

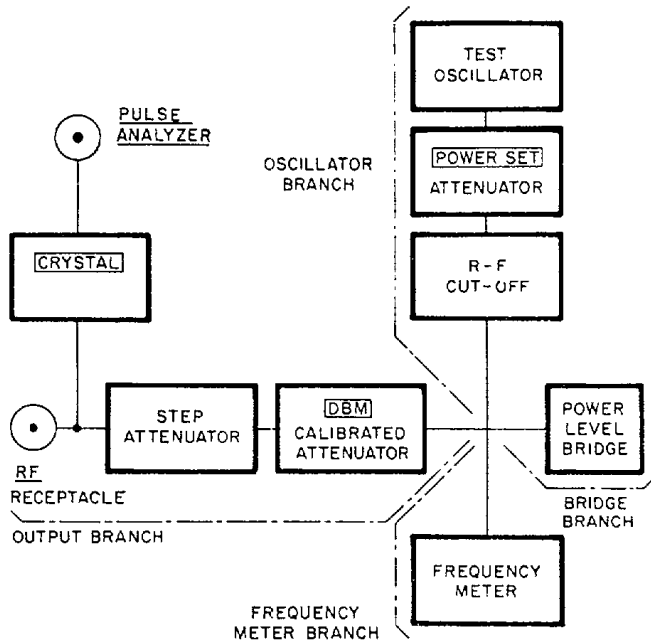

Figure 2-3. Simplified Block Diagram Showing Plumbing Branches

d. FREQUENCY MEASUREMENTS OF OUTPUT SIGNALS.-The frequency of the output signal is measured by the frequency meter. When its cavity is tuned to the frequency of the test signal, part of the energy is absorbed, causing a dip in the bridge meter reading and a decrease in the power output of the test set. If the test set is frequency modulated and the frequency meter is tuned within the swept frequency band, power will be absorbed each time the sweep reaches the resonant frequency of the meter. The resulting decrease in power output will appear as a small dip in the frequency response curve seen in a synchroscope or oscilloscope.

e. FREQUENCY MEASUREMENTS OF INPUT SIGNALS.

(1) The frequency of input signals is measured

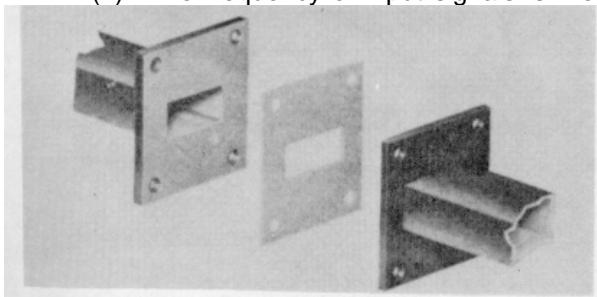

Figure 2-4. Gasket-Flange Joint

in the same way as the frequency of output signals. The energy to be measured is fed into the RF connector, and the frequency meter absorbs part of the power at resonance causing a dip in the meter reading.

(2) When the frequency of RF pulses of very short duration (of the order of 0.3 microseconds) is being measured, the meter will not dip enough to identify clearly the resonant point with the usual thermistor bridge sensitivity. To remedy this situation a switch is provided that changes the circuit and gives about four times the usual sensitivity.

2. RF PLUMBING COMPONENTS.

a. GENERAL.

(1) Figure 2-2 shows the physical layout of the RF plumbing components of the test set. They are principally wave guide sections fitted with an RF output and detector section, a step attenuator, a calibrated variable attenuator, a frequency meter, a thermistor bridge assembly, and a tube mount. Most of the components are assemblies that have been calibrated and cannot be taken apart in the field and still be expected to give accurate measurements. Each component can, however, be replaced as a complete unit and this may be done easily and successfully in the field by trained personnel.

(2) The plumbing is arranged in three general branches: the input-output branch, the oscillator branch, and the thermistor bridge branch. These three branches join in a T-section, at which point a frequency meter is also located. Figure 2-3 is a simplified block diagram showing this arrangement.

(3) The RF plumbing connections are of the gasket and flange type (See figure 2-4.) and not the choke-flange type. (See figure 2-5.) The gasket is made of thin, silver plated brass and the joint is held together by four screws.

b. TUBE MOUNT ASSEMBLY.

(See figures 2-6 and 2-7.)

(1) The tube mount assembly holds the oscillator tube (2K25) V104 and also contains the POWER SET attenuator within a section of wave guide. When the oscillator tube is put into the socket, the output probe of the tube projects into the wave guide and serves as an antenna to radiate RF power down the guide. The distance from the probe to the shorted end of

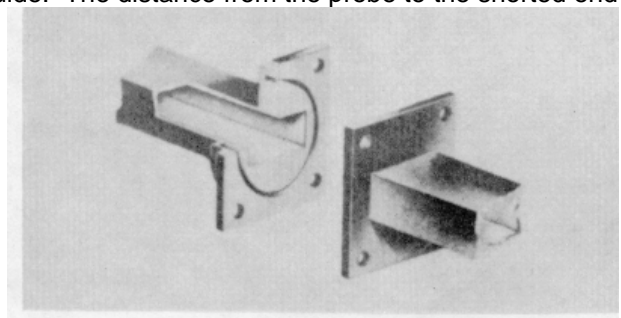

Figure 2-5. Choke-Flange Joint

## THEORY OF OPERATION

## Section 2 Paragraph 2 b (1)

the guide is effectively one-quarter wave length so that energy radiated toward this end is reflected back in phase with the energy radiated toward the output end.

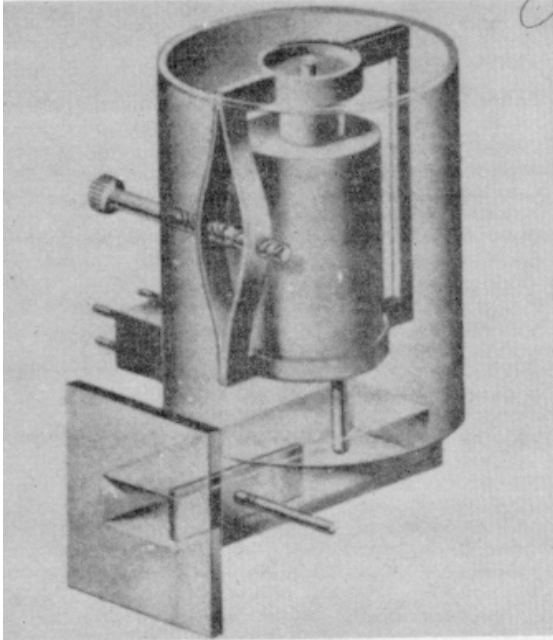

Figure 2-6. Tube Mount Assembly, Simplified Phantom View

(2) The POWER SET attenuator regulates the power that is delivered to the other plumbing components. The attenuator is a rectangular strip of glass, coated with a resistive material that dissipates some of the energy. It is placed longitudinally in the wave guide. Since the electric field strength varies from maximum at the center to zero at the edge, the power dissipated by the glass strip increases as it is moved toward the center of the wave guide, thereby reducing the amount delivered to the other components.

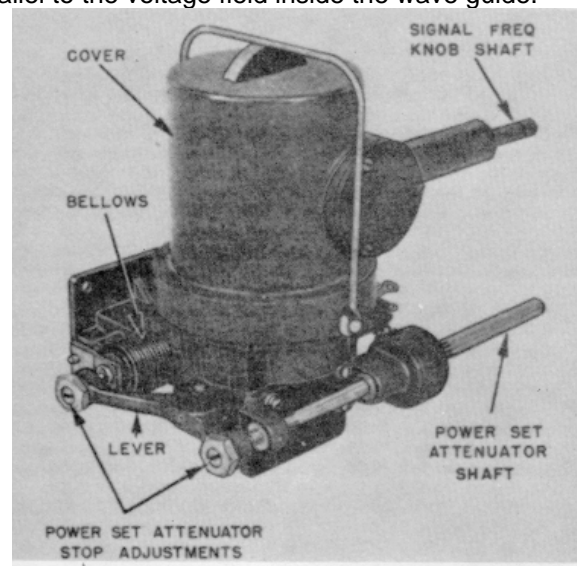
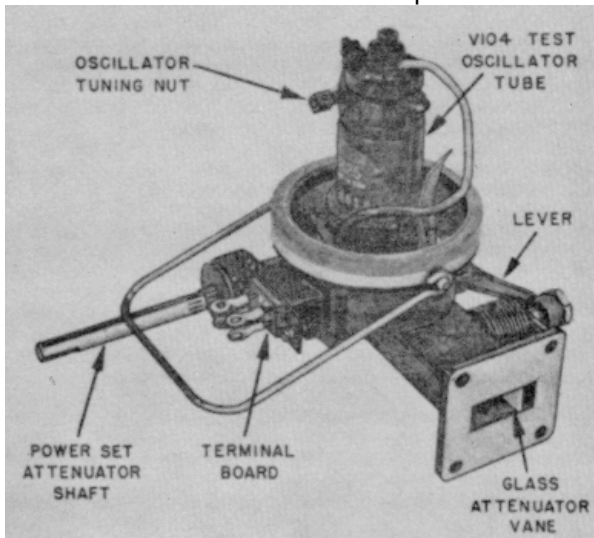

Figure 2-7. Tube Mount Assembly

(3) The metal case around the oscillator tube serves as an RF shield to reduce leakage. It also tends to maintain the temperature around the tube and thereby protects it from frequency changes due to air current variations.

### c. FREQUENCY METER ASSEMBLY.

(See figures 2-8 and figure 2-9.)

(1) The frequency meter assembly consists of a cavity resonator with a dial and a T-section of wave guide that contains the RF cut-off switch. This switch is simply a sliding door that opens or closes the entrance that connects with the oscillator wave guide. The T-section connects the three branches of plumbing. (See figure 2-3.)

(2) The frequency meter itself is a cylindrical cavity resonator, the volume of which may be varied by moving the plunger in or out. It is coupled to the T-section through a hole in the wall of the wave guide opposite the RF cut-off switch. When the cavity is one-half wave length long, it resonates and presents a low impedance at the coupling hole, absorbing some of the power in the wave guide which causes a decrease in power level at the thermistor bridge.

(3) The frequency meter is calibrated to read directly in megacycles/10 (tens of megacycles). That is, each reading must be multiplied by ten to give the frequency in megacycles.

### d. THERMISTOR MOUNT ASSEMBLY.

(See figures 2-10 and figure 2-11.)

(1) The thermistor mount is a section of wave guide containing the three thermistor elements of the wattmeter bridge circuit. A bead thermistor is mounted parallel to the voltage field inside the wave guide.

ORIGINAL

## THEORY OF OPERATION

## Section 2 Paragraph 2 d (1)

matching stub and shorting plug are used to match the impedance of the connected plumbing components.

(2) Two disc thermistors for temperature compensation are mounted on the outside of the wave guide portion of this assembly. These thermistors have relatively large mass and their resistance is affected principally by the ambient temperature of the thermistor mount. Operation of the thermistor bridge circuit is described in par. 3e.

that external sources of RF signal levels may be measured up to 30 db above 1 milliwatt average; also, so that the internal signal generator may deliver signals at levels down to a value of 85 db below 1 mw. Each attenuator is a thin strip of glass coated with resistive material and mechanically mounted so that its position in a section of wave guide can be varied. Two attenuators in series are used because the limitations of the glass strips are such that the loss required for measurements

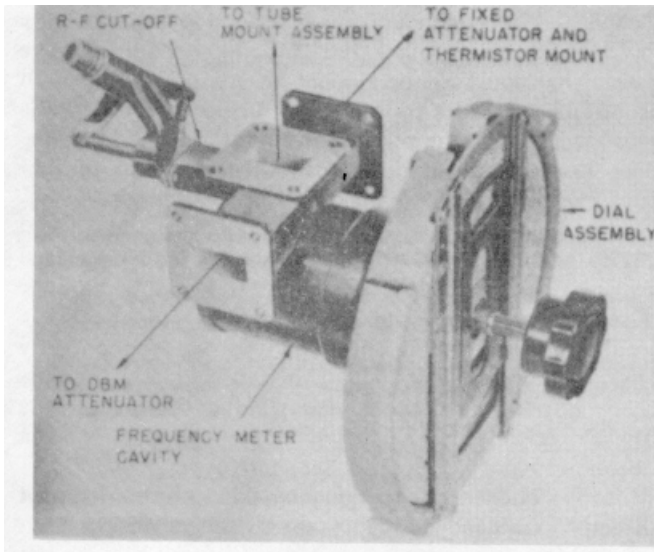

Figure 2-8. Frequency Meter Assembly

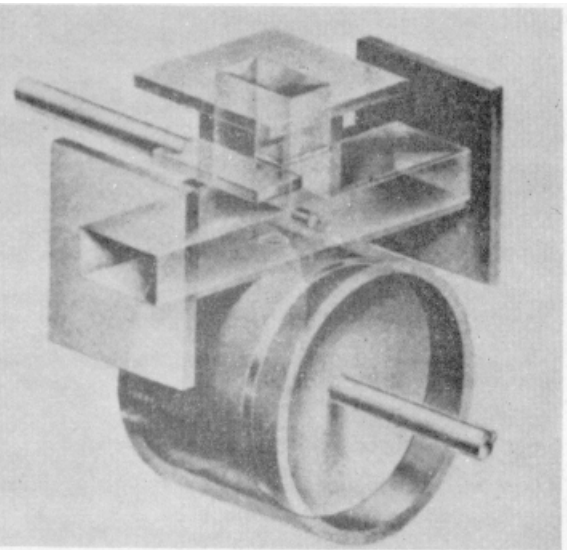

Figure 2-9. Frequency Meter Assembly, Simplified Phantom View

(3) The meter shunt resistor, R201, attached to the thermistor mount, changes the sensitivity of the bridge meter so that it corresponds to the sensitivity of the thermistor bridge. This makes thermistor mount assemblies interchangeable without affecting the accuracy of the power measurements.

cannot be accomplished in one attenuator. One assembly is the variable I)BM attenuator; the other is the step or dual attenuator which affords two fixed amounts of loss governed by the position of the TEST knob on the front panel.

### e. ATTENUATORS.

(See figures 2-12, 2-13, 2-14, and 2-15.)

### f. ATTENUATION.

(1) The test set is provided with attenuators so

(1) The test set is provided with attenuators so

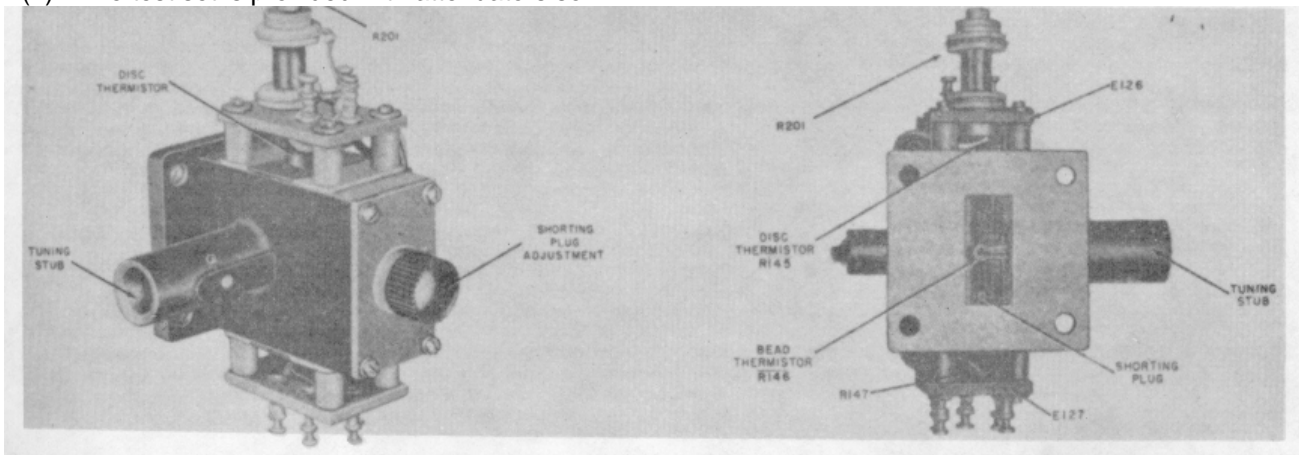

Figure 2-10. Thermistor Mount

## THEORY OF OPERATION

position and 40 db loss when in the RECV position. The variable DBM assembly at the counterclockwise setting has a loss of 2 db; and when it is in series with the 5 db minimum of the step attenuator the total loss of both units added together is 7 db.

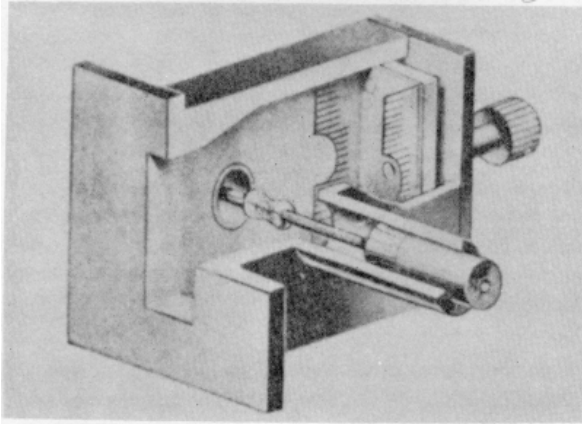

Figure 2-11. Thermistor Mount, Simplified Phantom View

The dial of the DBM assembly is engraved to show 1 db markings and indicates a loss of 7 db at the start of the upper scale for the TRAN setting of the TEST knob. It will be noted that the DBM dial numbers do not exceed +30 dbm which is equivalent to an average power level of 1 watt. When measuring levels

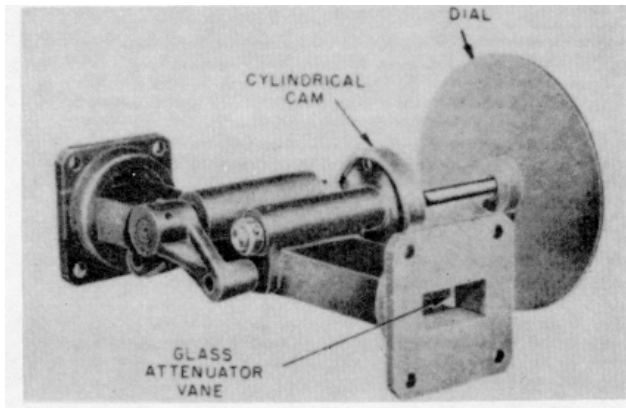

Figure 2-12. DBM Calibrated Attenuator

greater than 1 watt average, an external attenuator or directional coupler of known attenuation must be connected in series with the input of the test set to prevent damage to the glass strips in the attenuator assemblies.

(2) The RECV setting of the TEST knob is used

## Section 2

### Paragraph 2 f (1)

when delivering a low level signal for receiver tests, and places the step attenuator in the 40 db position. The fixed 40 db loss of this unit plus the insertion loss of the DBM assembly permits the loss of the combination to be 42 db minimum to 85 db maximum depending upon the setting of the DBM dial.

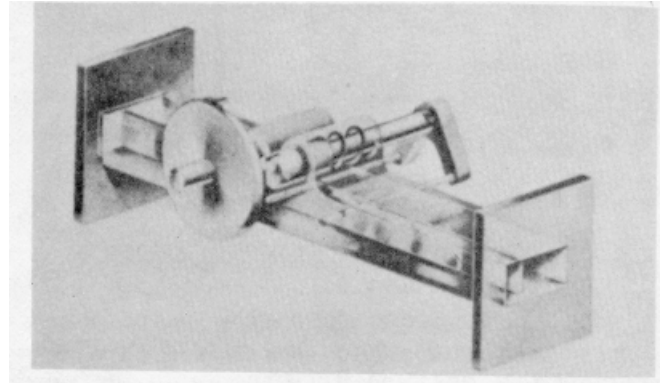

Figure 2-13. DBM Calibrated Attenuator, Simplified Phantom View

Since 1 milliwatt of RF power is fed to both the attenuators in series, the output power will be 42 db to 85 db below 1 mw or -42 dbm to -85 dbm as engraved on the lower scale of the DBM dial.

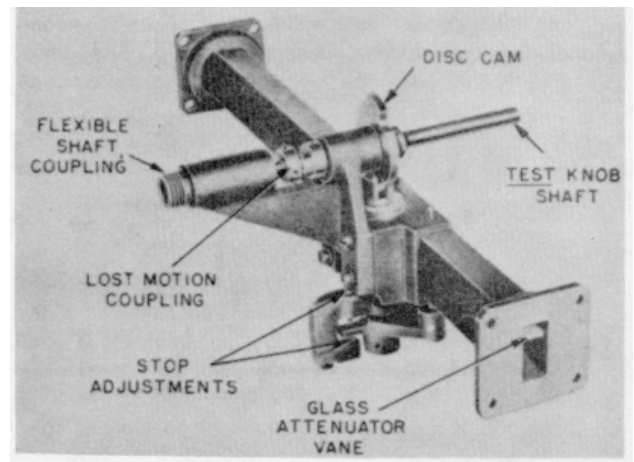

Figure 2-14. Step Attenuator

(3) The Red-Dot setting of the TEST knob is used only when attempting to locate the signal by means of an insensitive detector or poorly tuned receiver. Consequently, a calibration at this range is not necessary. The internal oscillator delivers RF energy through both attenuators. The step attenuator is in the 5 db loss position and permits an approximate output of -7 dbm to -45 dbm.

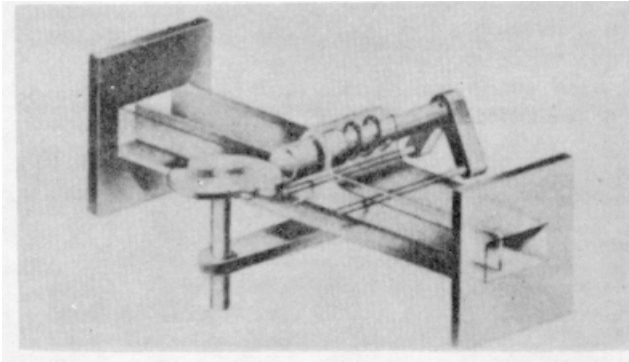

Figure 2-15. Step Attenuator, Simplified Phantom View

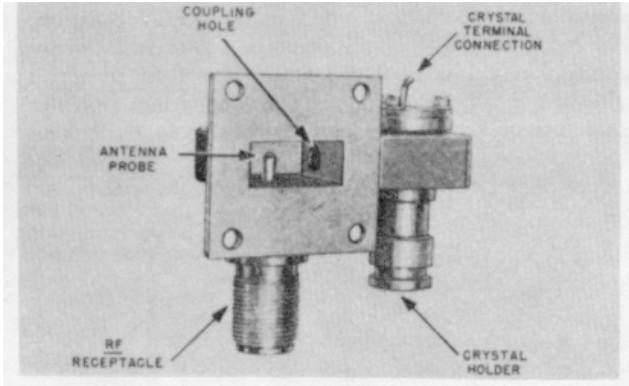

Figure 2-16. RF Output and Detector Section

g. RF OUTPUT AND DETECTOR SECTION.  
(See figure 2-16.)

(1) The RF output and detector section consists of a crystal detector and a coaxial cable to wave guide coupling that links the RF connector to the wave guide plumbing. The center conductor of the RF connector projects into the wave guide and is in effect an antenna or probe that radiates into or absorbs from the wave guide depending upon the way it is used. The shorted end of the guide acts as a reflector, being located an optimum one-quarter wave length behind the probe. The output impedance at the RF connector is nominally 50 ohms and is designed to match a 50 ohm coaxial cable to the impedance of the wave guide as closely as possible over the test frequency range of 8500 to 9600 mc.

(2) The crystal detector portion is another section of wave guide that is iris-coupled to the main

section. It is terminated by a silicon crystal diode that rectifies RF power for triggering the sweep generator and for observing the RF envelope.

3. ELECTRICAL CIRCUITS. (See figure 5-15.)

a. GENERAL. --Test Set TS-147D/UP receives and measures the power level and frequency of incoming signals. Also, it supplies and measures the power level and frequency of outgoing modulated and CW signals. The electrical circuits of TS-147D/UP consist of a Trigger Detector and Amplifier Circuit, a Blocking Oscillator Sweep Circuit, an Oscillator Circuit, a Thermistor Bridge Wattmeter Circuit, and a Power Supply Circuit.

b. TRIGGER DETECTOR AND AMPLIFIER CIRCUIT. (See figure 2-17.)

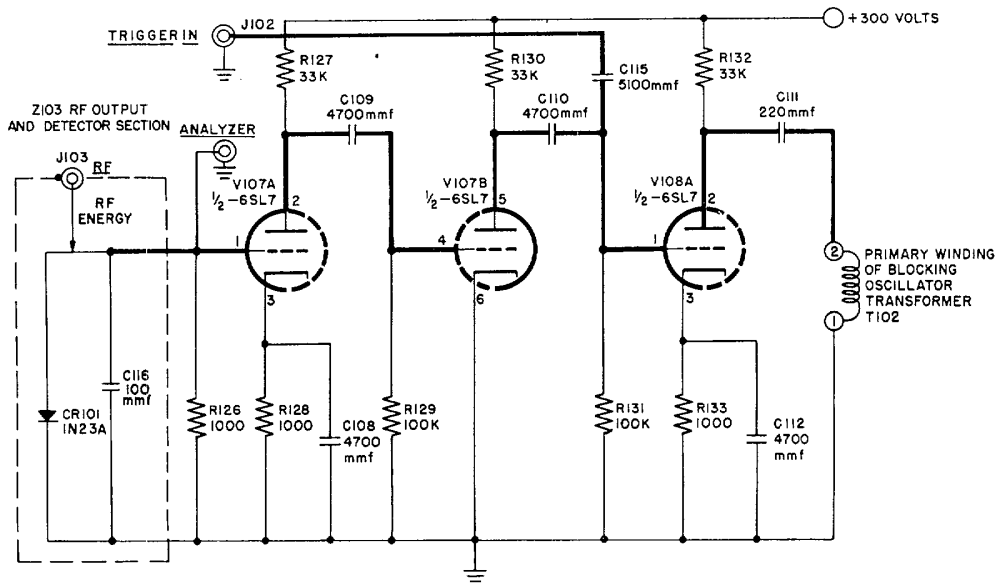

Figure 2-17. Trigger-Detector and Amplifier Circuit, Simplified Schematic

(1) The trigger detector and amplifier circuit provides the means for triggering the frequency sweep generator from RF pulsed power applied to the RF connector. The RF pulses are detected by a 1N23A crystal diode (CR101) in the RF output and detector section, the resulting voltage being applied to the trigger amplifier. The detected RF pulse can be observed by connecting an oscilloscope to the PULSE ANALYZER connector J106. The amplifier has three stages, is resistance coupled, and consists of one and one-half 6SL7 twin triodes, V107A and B and V108A, with a voltage gain of approximately 500. The voltage pulses from crystal CR101 are positive when applied to the grid of V107A, negative to the grid of V107B, positive to the grid of V108A, and negative at the plate of V108A. These negative pulses go through C111 to the primary winding of the blocking oscillator transformer (T102) where inversion takes place, thus delivering a positive pulse to trigger the blocking oscillator sweep circuit.

(2) Normally positive video trigger pulses applied to the TRIGGER connector (J102) are passed to the grid of V108A through C115 where they are treated in the same manner as above. Video trigger pulses are used when the equipment under test does not provide RF pulses.

(3) Trigger voltages are available at the TRIGGER connector from the rectified RF pulse (amplified by V107A and V107B), however, the voltage of the trigger is a function of the RF input and is likely to be insufficient to use as a trigger source. The shape of this trigger is also a function of the RF input. Another consideration in determining the suitability of this trigger is the input impedance of the equipment to be triggered. To low an input impedance may stop the blocking oscillator in the test set from operating.

#### c. BLOCKING OSCILLATOR SWEEP AND EXTERNAL MODULATION CIRCUIT. (See figure 2-18.)

(1) The frequency sweep circuit for the test oscillator (V104) is composed of a triggered blocking oscillator and an integrating network wherein the actual sawtooth waves are formed. The blocking oscillator consists of one-half of a 6SL7 twin triode (V108B) and a three winding transformer (T102). The circuit is conventional except that the grid is biased below cutoff so that a positive trigger pulse of sufficient amplitude to overcome the bias is necessary to start each cycle. The bias is applied to the cathode from the voltage divider R134 and R135.

(2) The sawtooth voltage is generated by the discharging and charging, from the B+ voltage, of capacitor C114. C114 represents the wiring capacitance of the wiring from SWEEP ADJUST to ground. The charging is slow compared to the subsequent rapid discharge of C114 by the blocking oscillator (V108B) when it receives a trigger pulse. When such a pulse is fed to transformer T102, a positive pulse appears

between grid and ground of the tube, causing plate current to flow. Because of the positive feedback between the plate and grid windings of T102 (windings 3-4 and 5-6), the plate current increases rapidly and is limited only by the grid and plate losses. During this time, the tube draws the large plate current required from C114, causing its charge to decay rapidly until it can no longer support the tube losses. When this happens, the plate current drops abruptly to zero

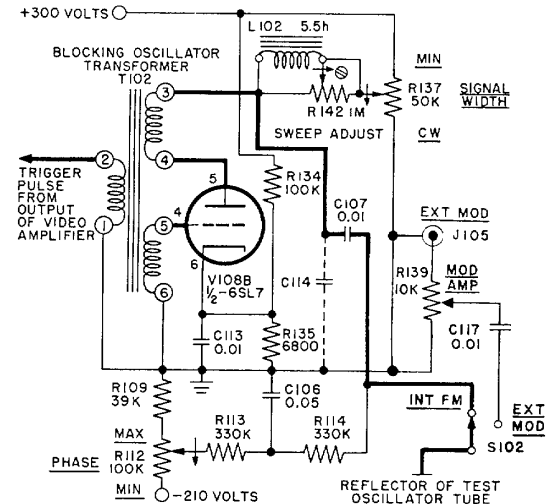

Figure 2-18. Blocking Oscillator Sweep and External Modulation Circuit

where it remains cut off until the next trigger pulse. When V108B is cut-off, C114 is charged through L102 and R142. L102 and R142 make the charge approximately linear. The voltage at C114 is therefore a sawtooth waveform that is coupled to the oscillator through C107. It delivers a modulating sawtooth sweep voltage through C107 and S102 (in INT FM position) to the reflector of the klystron test oscillator V104.

(3) The amplitude of the sweep voltage depends upon the maximum voltage across capacitor C114 and can be adjusted from 0 to +300 by the SIGNAL WIDTH potentiometer R137. The limits of the control are marked CW and MIN on the control panel. At the CW or grounded end, no voltage is fed to recharge C114. Consequently, a sawtooth sweep is not available to swing the test oscillator frequency. The MIN (sweep) end of R137 corresponds to a full +300 volts applied to C114. The theory of this is explained in par. 3d in which the klystron tube is described. These panel markings refer to the effect of the SIGNAL WIDTH control on the oscilloscope pattern used during receiver performance tests.

(4) When it is desired to modulate the test set with pulses (square waves, etc.), an external pulse generator producing a negative pulse of approximately 50 volts can be connected to the EXT MOD connector



## THEORY OF OPERATION

## Section 2 Paragraph 3 c (4)

and S102 put in the EXT MOD position. This puts the external modulation onto the reflector of the klystron through R139 and C117. R139 is the MOD AMP potentiometer and allows for the setting of the pulse amplitude on the klystron and thus the mode of oscillation of the klystron.

will overtake the slow moving electrons and bunching will take place just as the stream returns to the resonator. Thus RF energy will be delivered to the resonator, the frequency depending upon the spacing between bunches. Energy is taken from the tube by a coaxial probe that is terminated in the resonant cavity

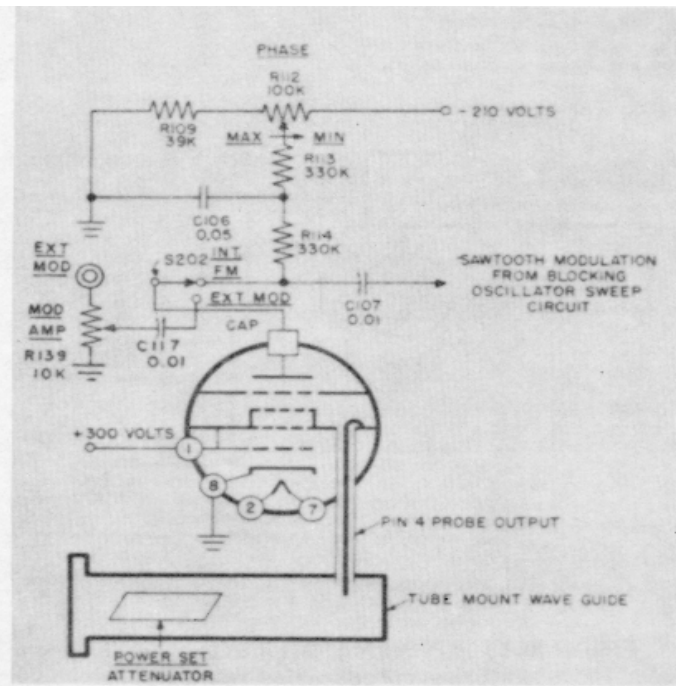

Figure 2-19. Test Oscillator Circuit

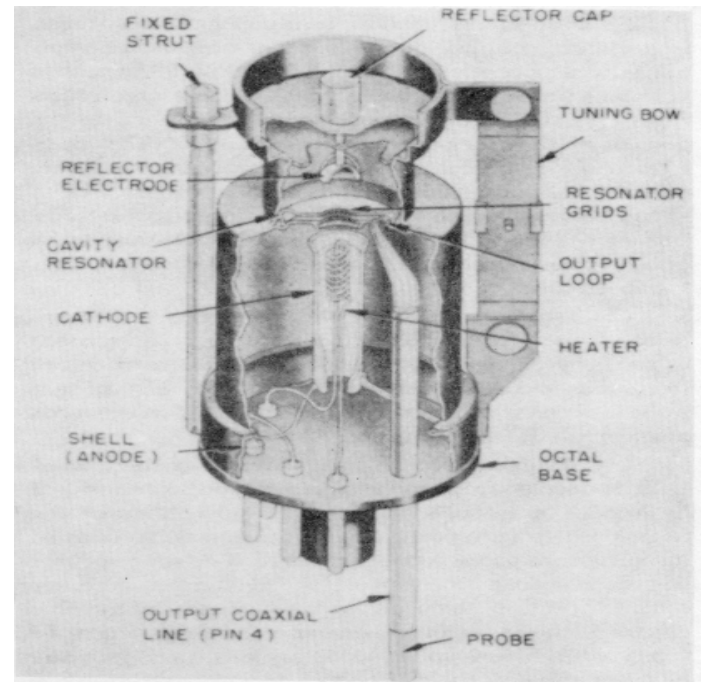

Figure 2-20. Test Oscillator Tube Cut-away View

### d. OSCILLATOR CIRCUIT. (See figure 2-19.)

(1) The type 2K25 reflex klystron tube V104 (See figure 2-20.) used in the test set is a velocity modulated microwave oscillator. It contains an electron gun that produces a focused electron beam of uniform velocity, a cavity resonator (tunable through the range of operating frequencies), and a reflector electrode that decelerates and returns the electron beam towards the resonator.

The electrons are emitted from the cathode and are accelerated by the positive potentials on the grid and the resonator grids. Random variations in electron emission tend to start the resonator into oscillation and produces an oscillating potential between the resonator grids. When this oscillating potential is positive the electrons are accelerated; when it is negative the electrons are retarded. The result is that the electrons in the stream that flow through the resonator grids towards the reflector travel at different speeds. Arriving near the reflector, which is maintained at a negative potential, the electrons are repelled. If the reflector voltage is correctly adjusted, the fast moving electrons

by a loop. When the tube is put in the socket of the tube mount, the coaxial probe extends into the wave guide and acts as an antenna to radiate power.

(2) There are two methods of tuning a reflex klystron tube. The first is to tune it mechanically by varying the volume of the resonator chamber. The tube is mechanically tuned by turning the squareheaded nut mounted on it and is covered by about 3 1/4 turns of the SIGNAL FREQUENCY knob.

(3) The other method of tuning the oscillator is to vary the reflector voltage. When the voltage is correct, the transit time and bunching of the electrons will sustain oscillation at the natural resonant frequency of the cavity. If the reflector voltage is varied slightly, the rate at which electron bunches arrive at the resonator cavity will change. This will cause a change in frequency, and also the power will drop as the frequency moves away from the natural resonant frequency of the cavity. (See figure 2-21.) Varying the reflector voltage

ORIGINAL

can cause the frequency of the oscillator to be swept over a range of approximately 25 to 75 megacycles.

(4) As its reflector voltage is varied, the tube will oscillate in different modes, the four lowest corresponding roughly to reflector voltages of minus 30,

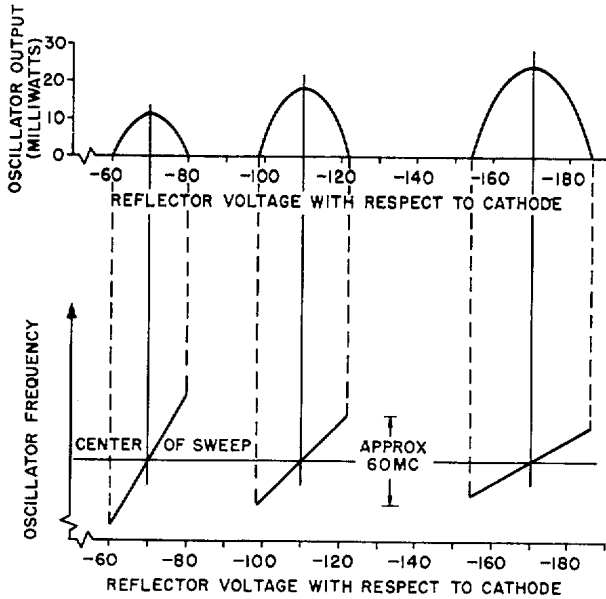

Figure 2-21. Reflex Klystron Characteristics

minus 75, minus 110, and minus 170 volts with respect to the cathode. The relation of power output and frequency to reflector voltage is shown for three modes in figure 2-21. These curves are general, and not precise for any one tube of the 2K25 type. They indicate that the power output of the tube is greater in the modes with more negative voltage on the reflector. However, the range of frequency sweep within each mode decreases with increasing negative reflector voltage. Between the half-power points of the minus 75 volt mode, the frequency range is approximately 60 megacycles. In the 110 volt mode, the frequency range is approximately 35 megacycles, and in the 170 volt mode, it is approximately 25 megacycles. Frequency data for the 30 volt mode have not been determined accurately because of erratic and undependable behavior. The reflex klystron 2K25 used in Test Set TS147D/UP does not use the full range of the available frequency excursion described in the foregoing data. (See par. 3d (3) and (4).)

(5) Figure 2-22 shows how the frequency of the oscillator tube is modulated by varying the reflector voltage. If the sawtooth voltage is applied to the reflector about the center value of 110 volts (DC level) as shown, the frequency of the oscillator will be swept through one or more modes and the output will be frequency modulated. The number of modes covered depends upon the amplitude of the sawtooth. This is determined by the setting of the SIGNAL WIDTH control.

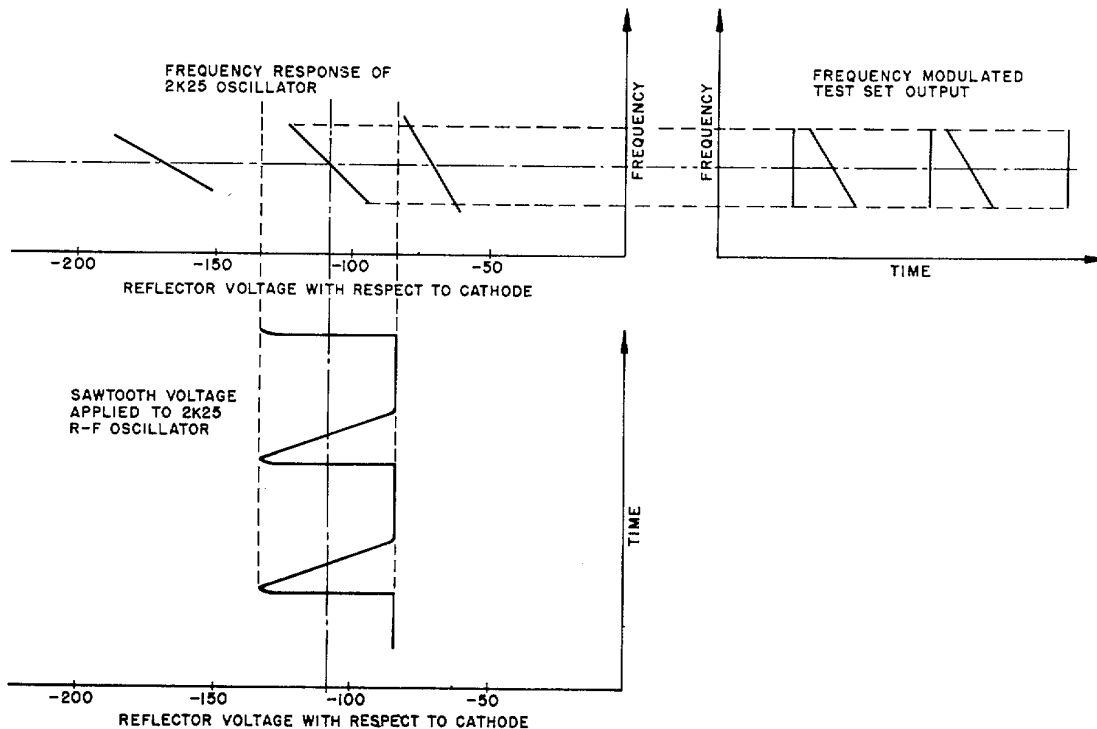
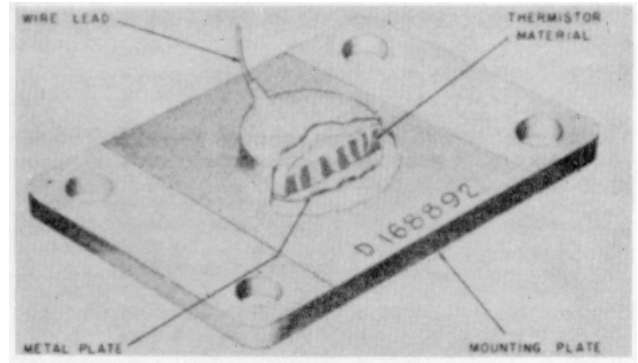

Figure 2-22. Test Oscillator Modulation

(6) The time at which the center frequency of a mode is reached occurs later as the negative DC level is reduced and vice versa. Such a change appears as a shift in the position of the frequency response curve along the horizontal axis of the oscilloscope. The PHASE knob controls the steady DC bias applied to the reflector which is added to or subtracted from by the sawtooth sweep voltage.

**e. THERMISTOR BRIDGE WATTMETER CIRCUIT.**

(1) GENERAL. --The thermistor bridge wattmeter is the power measuring device of the test set. It is composed of a Wheatstone bridge circuit having a thermistor element in one arm which varies its resistance with temperature. A thermistor (the name is a contraction of thermal resistor) decreases in resistance as the temperature increases. When current passes through the thermistor, a small amount of power is dissipated in it, which raises the temperature, thus lowering the resistance. This current may be caused by the DC bridge voltage, the RF field around the thermistor, or both. When the DC current in the circuit and the effects of the ambient temperature are properly controlled, the thermistor is used to establish



*Figure 2-24. Disc Thermistor*

**(2) BASIC BRIDGE CIRCUIT. (See figure 2-25.)**

(a) The basic bridge circuit consists of the equal resistors R115, R116, and R119 in three arms of the bridge, and the small bead thermistor (which at ambient temperatures has a resistance greater than 250 ohms) as the fourth arm. Current flows from the junction of R115 and R116 through the parallel arms to ground. When the bridge is in electrical balance, no current will flow through the meter since all the resistances are equal.

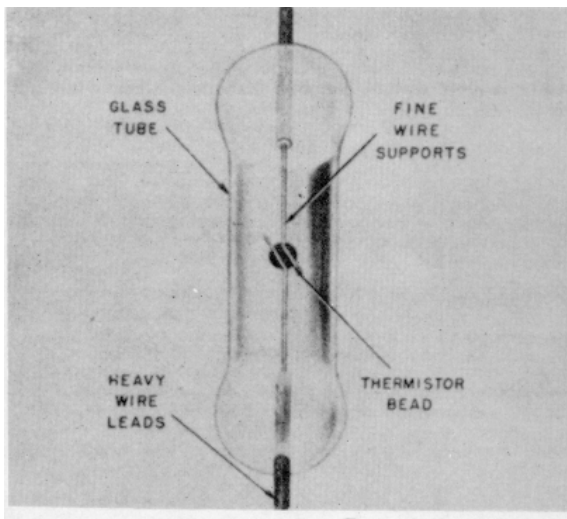

*Figure 2-23. Bead Thermistor*

a reference level of power. Figure 2-23 illustrates the bead type thermistor, the glass envelope' of which is about three-eighths of an inch long. Since a thermistor is sensitive to ambient temperature, the problem encountered in the design of such a bridge circuit is that of making the power calibration independent of external or room temperature. This is accomplished by the use of two disc thermistors. (See figure 2-24.) They are relatively insensitive to small values of current flowing through them; but due to their larger mass, are responsive to changes in ambient temperature.

**ORIGINAL**

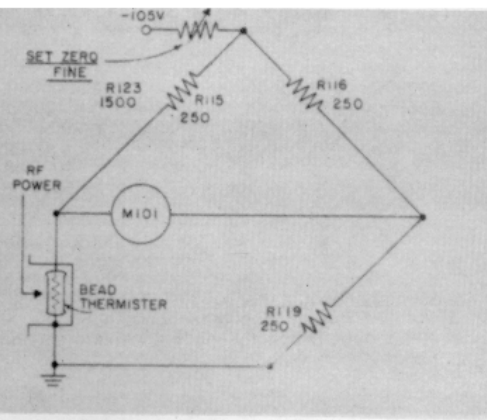

*Figure 2-25. Basic Thermistor Bridge Circuit*

(b) The initial change in resistance of the bead thermistor is made by adjusting the current through it. The constants of the bridge are such that when the meter reads at the extreme left of the scale at the point marked SET ZERO, actually 150 microamperes are flowing through the meter. The alteration of current through the bead thermistor is made at the SET ZERO-COARSE and FINE variable resistors R124, R123 which vary the voltage to the bridge and thus the current passing through the thermistor and the meter.

(c) Although the initial adjustment of current in the bridge is referred to as "balancing" the meter, it is in fact the adjustment of the bridge for an unbalance of a known amount. True balance is then brought about by applying one milliwatt of RF power to the bead thermistor, at which time the meter needle moves to the zero current point marked SET POWER on the meter scale.

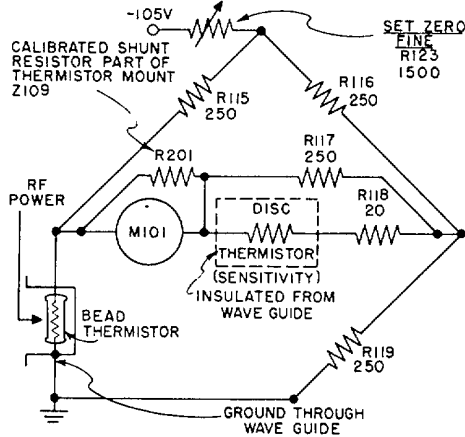

Figure 2-26. Thermistor Bridge Circuit Showing Sensitivity Compensation

(3) SENSITIVITY COMPENSATION.  
(See figure 2-26.)

(a) The sensitivity of the bridge circuit remains constant over a broad temperature range. However, due to the sensitivity of the thermistor for changes in ambient temperature, a method of compensation is required. This correction is accomplished by increasing the voltage across the bridge and automatically increasing the resistance of the meter arm when the temperature goes down and vice versa.

(b) Since thermistors have the characteristic of increasing in resistance with a decrease in temperature, a disc thermistor is put in series with the meter. (See figure 2-26.) Resistor R118 in series and resistor R117 in parallel with this thermistor have been inserted to get the correct rate of change in resistance with varying degrees of temperature.

(4) DC VOLTAGE COMPENSATION.  
(See figure 2-27.)

(a) To eliminate frequent resetting of the SET ZERO-FINE control, a way has been provided for automatically increasing the current through the bead thermistor with decreasing temperature. A disc thermistor, similar to that used in the meter arm, is put in parallel with the bridge.

(b) Since decreasing temperature causes increasing resistance of the thermistor, less current is shunted to ground which results in a smaller drop

through R125, R143, R124, and R123. Thus more voltage is applied to the bridge. A series and shunt resistor network (R120, R121, and R122) is used with this thermistor also to obtain the proper compensation characteristics over the required temperature range.

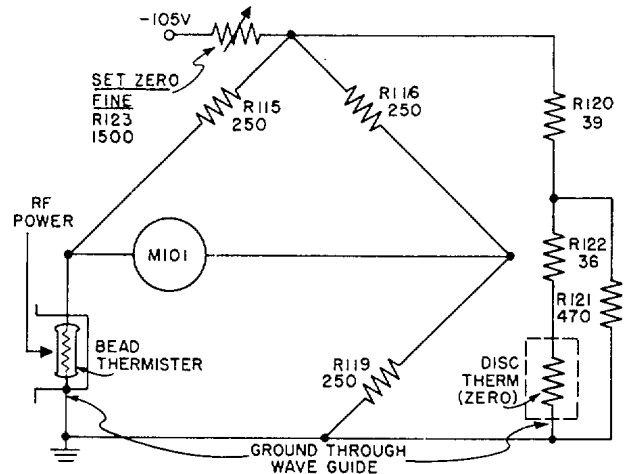

Figure 2-27. Thermistor Bridge Circuit Showing Voltage Compensation

(5) COMPENSATED BRIDGE CIRCUIT.

(a) The thermistor bridge used in the test set provides for both meter sensitivity and DC voltage compensation. (See figure 2-28.)

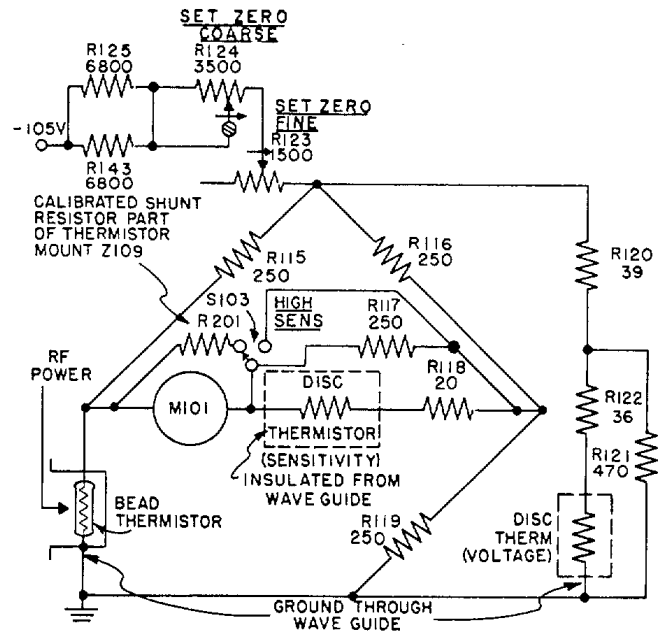

Figure 2-28. Complete Thermistor Bridge Circuit

(b) When the ambient temperature decreases, the resistance of the bead thermistor would tend to increase were it not for the voltage compensating thermistor whose resistance increases, allowing

additional voltage to be applied to the bridge. The additional current flowing through the bead thermistor will increase its temperature sufficiently to overcome the change in the ambient temperature, thereby holding the resistance of the bead arm of the bridge constant. In order not to throw the meter circuit out of calibration with the increased current flow in that section, another thermistor, whose resistance also increases with the temperature drop, is placed in series with the meter to correct the error.

(c) The compensating networks are designed for an average bead thermistor, the correction being fully automatic at approximately 0°C (32°F), 30°C (86°F), and 60°C (140°F). At intermediate points, the compensation is not exact, although it is satisfactory for practical purposes. These networks are not perfect for any one bead because of variations in the electrical characteristics of bead thermistors as a whole. As a result, the manual SET ZERO controls cannot be eliminated entirely.

(d) Resistor R124 (SET ZERO-COARSE) is a slotted control mounted within the test set and is accessible from the front panel. It is in series with the SET ZERO-FINE control R123 and is initially set for proper bridge voltage in conjunction with individual thermistor mounts.

(6) HIGH SENSITIVITY. --The thermistor bridge is used as the frequency meter indicator as explained in par. 2c(2). When measuring the frequency of short RF pulses, however, the meter deflection is not sufficient to give a good indication. Therefore, a momentary switch (S103) is provided that eliminates the sensitivity compensation and thus increases the meter deflection by about 4 times. The circuit for this position of S103 (HIGH SENS) is as shown in figure 2-27. S103 is a momentary switch to insure that excessive power is not applied to the bridge while the sensitivity

compensation is eliminated from the circuit and thus to prevent damage to the bridge.

f. POWER SUPPLY CIRCUITS.

(1) The power supply provides + 300, -105, and -210 volts for the electrical circuits. It consists of a full-wave rectifier (V101), an electronic regulator (V102 and V103), and a VR tube regulator consisting of V105 and V106. The rectifier supplies about 550 volts DC ungrounded, through a choke input L-filter. The VR tubes V105 and V106 on the negative side of ground act as a voltage divider and regulate the -105 and -210 volt supply. Also they provide negative bias for the regulator control tube in the electronic regulator. The regulator on the positive side of ground regulates and filters the +300 volt supply.

(2) The electronic regulator consists of a series regulator tube (V102) controlling the output voltage directly, and a regulator control tube (V103) controlling the grid voltage of the regulator tube. The regulator control tube (V103) is connected as a DC amplifier to amplify any voltage variations in the regulated output. The amplified variations, when applied to the control grid of the regulator tube (V102), cause it to change its voltage drop in a direction tending to compensate for the variation.

(3) The VR tube regulator consists of two OC3/VR105 tubes (V105 and V106) in series. In normal operation, each tube maintains a constant voltage drop of 105 volts so that the total voltage across the two in series is 210 volts. The 105 volt drop across V105 is used to supply the thermistor bridge circuit in the test set. The total voltage (210v) of the two VR tubes forms the DC reflector voltage supply for the test oscillator tube (V104).

SECTION 3  
INSTALLATION

**CAUTION**

**DUE TO THE HIGHLY COMPLEX NATURE OF TEST SET TS-147D/UP, IT IS SUGGESTED THAT ONLY A QUALIFIED TECHNICIAN SHOULD BE PERMITTED TO MAKE THE FOLLOWING OBSERVATIONS AND TESTS.**

**1. UNPACKING.**

Exercise extreme care when unpacking the Test Set TS-147D/UP, particularly when prying off the top of the wooden packing case. After the instrument has been unwrapped, take off the cover from the combination instrument and carrying case.

**CAUTION**

**SET THE POWER SET KNOB FULLY COUNTERCLOCKWISE (MAXIMUM ATTENUATION) AND THE TEST KNOB IN THE TRAN POSITION BEFORE TURNING ON THE SET.**

**SET THE DBM ATTENUATOR FULLY COUNTERCLOCKWISE (MAXIMUM ATTENUATION) BEFORE CONNECTING THE TEST SET TO A RADAR OR OTHER SOURCE OF EXTERNAL RADIO FREQUENCY POWER.**

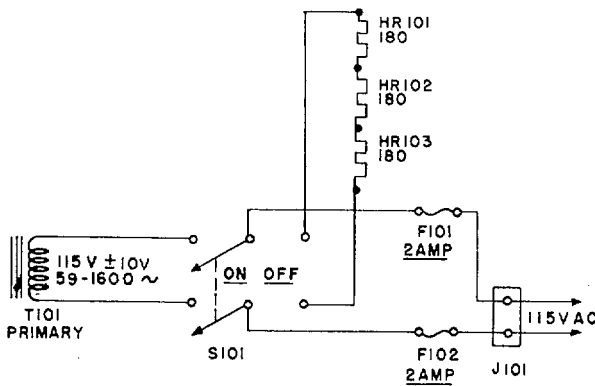

Figure 3-1. Primary Power Distribution Diagram

**2. INSTALLATION.**

**a. INSPECTION.**

(1) The cover contains the accessories and provision for storing operating spare parts, except for the spare thermistor mount which is to be fastened to the chassis with machine screws within the instrument at a

point behind the lower left corner of the front panel. (See figure 5-7.)

(2) Remove the chassis from the carrying case. To do this, keep the instrument flat with the front panel facing upward, unfasten the four thumb screws on the panel, and lift the chassis upward from the case, taking care not to bump the components against the cabinet flanges.

(3) Check all items against table 1-1. Inspect equipment thoroughly for possible damage during shipment. Check for broken or missing tubes and see that all connectors and tubes are properly seated.

(4) Rotate the SIGNAL FREQ knob to make sure that the coupling rotates the tuning nut on the oscillator tube (V104). There will be a firm tension on the knob when turned, with a slight backlash between the coupling and the tuning nut.

(5) With the instrument in the normal operating position, and no power applied, observe the needle of the bridge meter. It should be in the center of the meter scale at the SET POWER point. This setting, which indicates zero meter current, can be adjusted by the screw on the meter face.

**Note**

**WHEN THE THERMISTOR BRIDGE CIRCUIT IS IN OPERATION, THE METER NEEDLE WILL COME TO REST AT THE SET POWER POINT WHEN THE METER CURRENT IS ZERO.**

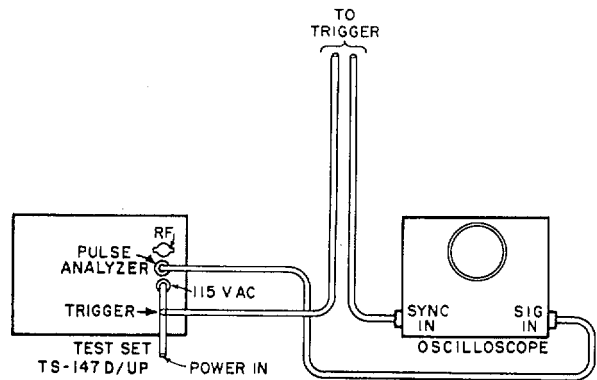

Figure 3-2. Preinstallation Check Diagram

**b. PREINSTALLATION TEST.**

(1) With the test set out of the carrying case, connect the power cord to the front panel receptacle and plug the other end into a source of 115 volts, 59

to 1600 cps AC power. Turn switch S101 to ON and allow one to two minutes for warm-up.

(2) During the warm-up period, the grain of wheat type dial lamps over the DBM and FREQUENCY dials should light as well as all tube filaments. The voltage regulator tubes (V105 and V106) should glow steadily. The needle of the bridge meter should deflect from the SET POWER point.

(3) After the warm-up period, with the TEST knob at TRAN, adjust the SET ZERO-FINE knob until the meter reads SET ZERO. If this is not possible, alter the position of the screw driver control at the front panel (SET ZERO-COARSE) until the meter needle is at the SET ZERO point with the SET ZERO-FINE knob in approximately mid-position.

(4) Turn switch S101 to OFF and remove plug from power source receptacle.

**CAUTION**

**THE TEST SET DRAWS CURRENT FROM THE AC LINE TO OPERATE THE CABINET HEATER WHEN THE POWER SWITCH IS IN THE OFF POSITION (SEE FIGURE 3-1).**

(5) Return test set chassis to its carrying case. Take care not to bump or injure components in the process.

c. LOCATION.

(1) Test Set TS-147D/UP is a portable instrument that requires no permanent location. It should be placed in such a position that the controls of the equipment being tested and those of the test set can be adjusted simultaneously. Also, the patterns on the oscilloscope should be visible. The temperature rise is such that the ventilation ports above and below the front panel must be kept unobstructed.

(2) If necessary, the test set can be strapped to a flat top bench by any convenient means, provided that at least 6 in. space on the top, rear, and each side is left clear for ventilation. The mounting feet insure adequate space on the bottom. With the cover removed, the space required is as follows: height 17.8 in., width 31.5 in., depth 14.0 in.

d. OUTLINE DIMENSIONS. --Figure 3-3 gives the outline dimensions of the test set.

**3. INITIAL ADJUSTMENTS.**

The equipment requires no critical initial adjustments before being put into operation. Performance checks, (See par. 4.) however, can be used to ascertain whether or not the test set is operating correctly.

**ORIGINAL**

**4. PERFORMANCE CHECK.**

a. Connect power cord to panel receptacle and power source as in para. 2b(1).

b. Set the following controls: (See figure 4-1.)

CONTROL	SETTING
EXT MOD-INT FM. ....	INT FM
SIGNAL WIDTH .....	Fully clockwise (CW).
PHASE	Fully counterclockwise (MIN).
TEST .....	RECV.
POWER SET .....	Fully counterclockwise (maximum attenuation)
SIGNAL FREQ.....	Middle of range

c. Turn the PHASE control slowly clockwise until the meter needle deflects to the right of the SET ZERO point. Note the magnitude of this deflection. If no deflection is observed, turn the POWER SET control about one-half turn clockwise and again adjust the PHASE knob as before. A deflection will indicate that the klystron tube is oscillating. Continue to adjust the PHASE control for maximum deflection. Adjust the POWER SET knob to bring the deflection to the SET POWER point at the center of the meter scale.

d. Continue to turn the PHASE control clockwise until the needle drops back to the SET ZERO position then again deflects toward the SET POWER mark. Note the value of each of these deflections. There should be at least three separate positions where the needle deflects in like manner, thereby indicating oscillations are taking place.

e. Adjust the PHASE control for the peak point of the largest deflection encountered in the previous paragraph. Adjust the POWER SET knob to move the meter needle to a point somewhat midway between the SET POWER mark and the right end of the meter scale. Start with the FREQUENCY knob in a fully counterclockwise position, then turn this control slowly clockwise until a dip is produced in the meter deflection. The dip should be at least 20% of half scale and should be quite sharp, approximately 1 mc wide. If a particular point on the frequency meter produces a very broad dip of greater amplitude, it will be caused by a spurious or unwanted mode of response. The true frequency meter reading will occur approximately 600 mc or 60 dial divisions higher. This will follow through for all frequencies within the range of the test set and the frequency meter. This condition may be used as a check on the correctness of tuning.

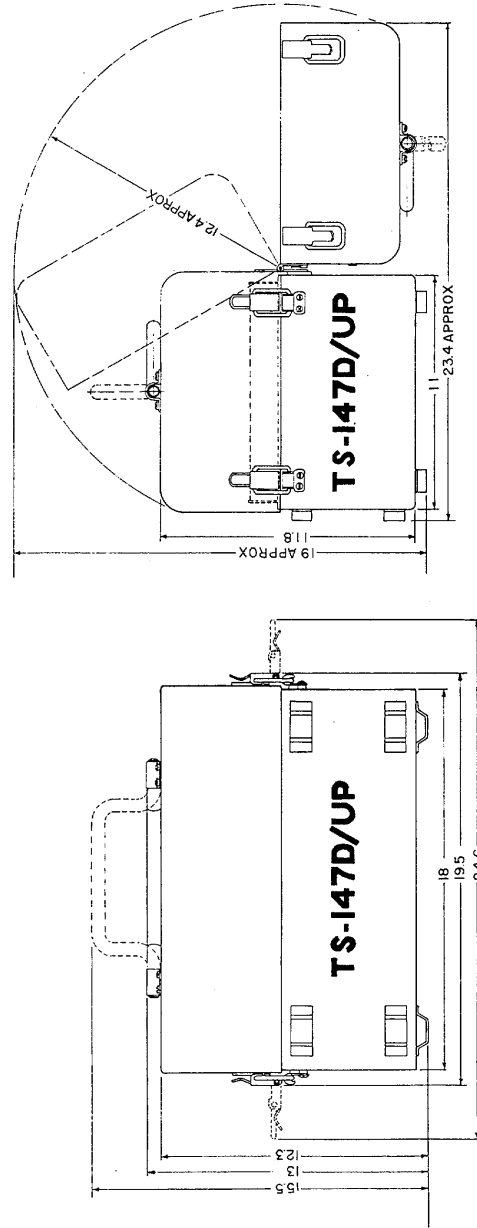

Figure 3-3. Test Set TS-147D/UP Outline Dimensional Drawing



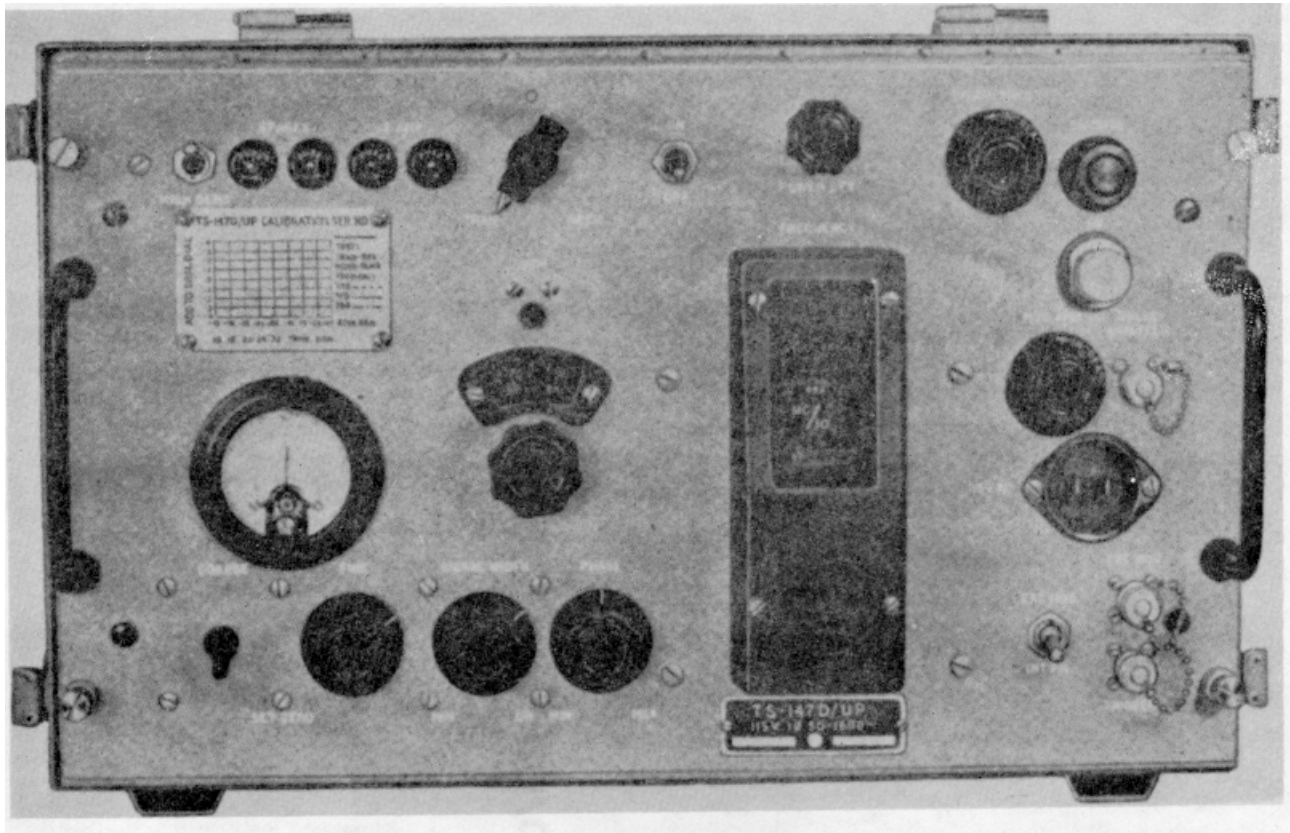

Figure 4-1. Test Set TS-147D/UP

SECTION 4

OPERATION

1. INTRODUCTION.

a. GENERAL.

(1) Test Set TS-147D/UP (See figure 4-1.) is a the portable power level wattmeter and microwave signal generator for testing and adjusting beacon and radar systems in the frequency band from 8500 to 9600 megacycles.

(2) The test set supplies microwave signals, either frequency modulated, or continuous wave, of known power level and frequency, and also accepts signals for power and frequency measurement. It can be pulse modulated from an external source.

(3) It contains a direct reading frequency meter and a power level wattmeter that, in conjunction with calibrated attenuators, reads power in dbm (decibels with reference to one milliwatt).

(4) In conjunction with an oscilloscope or synchroscope, the test set can be used for alignment and bandwidth measurements of radar receivers and for checking microwave plumbing. Using the FM signal of the test set, the horizontal sweep of an oscilloscope

is triggered so that the length of the trace is proportional to the frequency sweep of the FM signal. When the FM test signals are passed through the IF section or discriminator circuits of a radar and then displayed on the oscilloscope, the resulting pattern of the screen shows the receiver frequency response.

(5) A connector is provided for connection to an oscilloscope for viewing the envelope of an external pulsed signal.

(6) Some radar sets have a built-in directional coupler. If one is not provided, an external directional coupler of approximately 20 db insertion loss, such as Directional Coupler CU-205/U, CU-206/U, or CG-176/AP, should be installed. If none of these couplers are available, Pick up Antenna AT-68/UP, supplied with the set, may be used.

b. TESTS AND FORMULAS

(1) Tests that may be made on radar sets by using Test Set TS-147D/UP, are listed by paragraphs in table 4-1 together with necessary formulas and computation data.

TABLE 4-1. LIST OF TESTS AND FORMULAS

TEST	TITLE	PARAGRAPH	MODULATION
1A	Transmitter Average Power, $P_{AV}$ , Above + 10 dbm	6	
1B	Transmitter Average Power, $P_{AV}$ , Below +10 dbm	7	
2	Transmitter Frequency, $f_t$	8	
3	Receiver Frequency, $f_r$	9	FM
4	Receiver Bandwidth Measurement	10	FM
	Receiver Performance Figure, $P_m$ (Sensitivity)	11	FM
5	CW Signal Equal to Noise	12	CW
6	TR Recovery Time, Using FM	13	FM
7A	TR Recovery Time, Using CW	14	CW
7B	Transmitter Pulling and AFC Tracking	15	FM
8	Beacon Response of Radar	16	FM
9	Synthetic Target	17	FM
	Radar Receiver Tuning, Using FM	18	FM
	Space Loss with Pick-up Antenna	19	
	Pulse Analyzer	20	
	External Modulation	21	Pulse (external)
	Formula 1-Transmitter Average Power, $P_{AV}$ ,	22	
	Formula 2-Receiver Performance, $P_m$	23	
	Computing the Transmitter Performance Figure	24	
	Computing Rated Transmitter Average Power in dbm	25	
	Computing the Radar Overall Performance Figure S	26	
	Change in Overall Performance	27	

NOTE: General Operating Instructions are given in Paragraphs 1 through 5.

**2. OSCILLOSCOPE.**

**a. GENERAL.**-Although the radar system indicator may be used for display, a separate oscilloscope is preferable in most cases and is necessary for measurements of receiver bandwidth and recovery time. An oscilloscope or synchroscope which has a provision for a triggered start-stop sweep circuit known as "A" scan or equivalent (such as Oscilloscope TS-34/AP Series or TS-239/UP Series) may be used for this purpose.

**b. PRELIMINARY CONNECTIONS AND ADJUSTMENTS.**

(1) After the oscilloscope has been turned on, it should be set for an external triggered sweep, a start-stop type being preferable.

(2) Connect the trigger from the radar set, using RF cable assembly CG-530/U(6') (W102) or equivalent, to the Trigger or Sync. input of the scope. When the RF signal is used to trigger the test set, a trigger input to oscilloscope can sometimes be obtained by connecting from the TRIGGER connector on the test set to the trigger or Sync. input of the scope. This can be done only when the voltage and shape of the RF input are correct for the trigger circuit of the oscilloscope. Another consideration in determining the suitability of using this trigger is the input impedance of the trigger circuit of the oscilloscope. A low input impedance to the oscilloscope may stop the RF signal from triggering the test set.

(3) Connect the video output signal from the radar set to the Signal or Vertical input and adjust the gain for a convenient height on the screen.

(4) Set the Sweep Duration and/or the Horizontal Gain control until the pulse pattern on the screen is sufficiently enlarged and of a usable size. It may be necessary to delay the trigger on the oscilloscope in order to see the output pulse.

**Note**

THE ABOVE OSCILLOSCOPE ADJUSTMENTS AND CONNECTIONS ARE USED THROUGHOUT THE FOLLOWING TESTS WHENEVER AN OSCILLOSCOPE IS CALLED FOR.

**3. RADAR SET-PRELIMINARY CONNECTIONS AND ADJUSTMENTS.**

**a. GENERAL.**-Refer to the instruction book for the radar. The set should be turned on, but the antenna should not be rotating except when specifically required for a test.

**4. TEST SET TS-147D/UP-GENERAL OPERATING INSTRUCTIONS.**

(See figures 4-4, 4-5, 4-6, 4-7, and 4-8.)

**a. GENERAL.**-Test Set TS-147D/UP is a signal generator and a device for measuring the RF power

and frequency of radar equipment. To measure the radar output, it is necessary to couple the signal to the test set for measurement. Similarly, to measure the sensitivity and frequency alignment of a radar receiver, it is necessary to deliver the signal, as measured in the test set, to the receiver.

**b. MEASURING POWER WITH THE THERMISTOR BRIDGE WATTMETER.**

(See figure 4-5.)

(1) The thermistor bridge will measure the power output of the test set only when it is operating on CW. When externally pulse modulated, the average power output of the oscillator tube is insufficient to operate the bridge. (The average power of the pulsed output of a radar, however, is sufficient to show on the bridge.) Accordingly, when it is desired to deliver a measured level of pulsed power from the test set, it is always necessary to tune up on CW first and then switch to pulsed operation. If the proper control settings are made, the peak power of the pulses will be the same as the measured CW power.

(2) To make the initial adjustment of the wattmeter:

(a) Turn the POWER SET control fully counterclockwise (maximum attenuation);

(b) Turn the TEST knob to TRAN;

(c) Turn the DBM attenuator knob fully counterclockwise (maximum attenuation);

(d) Turn on the test set and adjust the meter needle to the SET ZERO point by adjusting the SET ZERO-COARSE and FINE controls;

(e) Allow the set to warm up, if necessary, and again adjust the meter needle to SET ZERO.

(3) To measure incoming power, as from a radar transmitter, after making the initial adjustment (See par. (2) above):

(a) Keep the TEST knob at TRAN;

(b) Turn the DBM attenuator knob clockwise until the meter needle reads SET POWER. At this point the power level at the bead thermistor is one milliwatt and the power level at the RF connector is the reading of the DBM attenuator in + dbm (decibels above one milliwatt).

(4) To measure outgoing power, as to a radar receiver, after making the initial adjustment (See par. (2) above.):

(a) Turn the DBM attenuator control fully counterclockwise (maximum attenuation).

(b) Adjust the TEST knob to the Red-Dot position or to REC V;

(c) Turn the POWER SET knob clockwise until the meter needle reads SET POWER. The SIGNAL WIDTH control must be at CW. (See also par. 4c.) At this point the power level at the bead thermistor is one milliwatt.

(d) Adjust the DBM attenuator until the desired result at the receiver is obtained.

**OPERATION**

The output at the RF connector will be the reading of the DBM attenuator in -dbm (decibels below one milliwatt).

**c. TUNING THE TEST SET OSCILLATOR.**

(1) There are two frequency adjustments for the oscillator tube (V104). The SIGNAL FREQ control tunes the resonant cavity within the tube (by mechanically changing its shape). (Clockwise rotation of the SIGNAL FREQ control decreases the frequency.) The other adjustment is the PHASE control which varies the reflector voltage of the tube and therefore the frequency of oscillation and the power output. The best procedure is to work primarily with the SIGNAL FREQ control in making frequency adjustments and to use the PHASE control to adjust for maximum power output at the particular frequency. Thus, when using the test set to deliver a measured power, adjust the PHASE control to give a maximum deflection on the meter when the klystron is operating on CW and then return the meter needle to the SET POWER point.

(2) When tuning the oscillator to a specific frequency, make a trial adjustment of the oscillator, measure the frequency, then reset the oscillator, etc. If the oscillator is within 10 mc of the desired frequency, usually the PHASE control need not be readjusted. Turn the SIGNAL FREQ control to the desired frequency. Do not set the frequency meter to the desired frequency and then try to tune the oscillator until a dip is observed on the power meter. This is a very unreliable method since the frequency and power output of the oscillator change rapidly as the SIGNAL FREQ and PHASE controls are turned. Consequently, a frequency adjustment usually will skip over the resonant point of the frequency meter.

**Note**

**TO AVOID RF LEAKAGE, AT ALL TIMES KEEP THE SHIELD ON THE KLYSTRON OSCILLATOR TUBE (V104).**

**d. DBM ATTENUATOR CALIBRATION CHART.**

(See figure 4-2.)

(1) Each DBM attenuator is individually calibrated and a correction curve is included with every test set. It is affixed to the inside of the cover of the carrying case over the list of contents decal.

(2) It will be seen that for the various dbm positions of the attenuator dial, positive or negative correction factors are indicated by the curves. These correction factors should be added to, or subtracted from (added algebraically to), the DBM dial readings to get the true attenuation for a particular measurement.

(3) Curves have been plotted for three frequencies, corresponding to each end (8500 and 9600 mc) and the center (9050 mc) of the operating range of the test set. The three curves in RED show the calibrations at these frequencies when the TEST knob is in the TRAN position. The three BLACK curves show (the corrections when the TEST knob is in the RECV position. (See figure 4-2.) 1

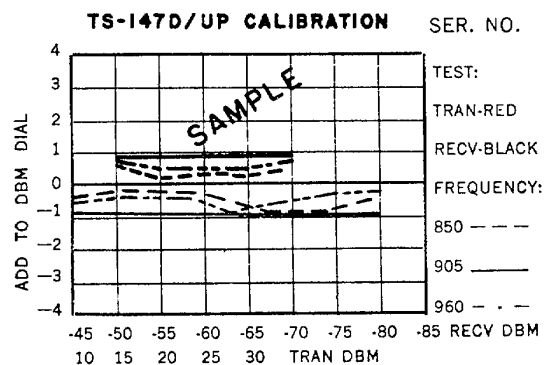

Figure 4-2. Typical Calibration Chart

**Note**

FIGURE 4-2 THE HEAVY LINES EXTENDING FROM +15 TO +35 DBM ON SURE 42 ARE FOR USE WHEN THE ST KNOB IS IN THE TRAN POSITION. THEY ARE PRINTED IN RED ON THE CALIBRATION CHARTS ISSUED WITH SE RADAR TEST SETS.

(4) Although for all practical purposes the corrections can be ignored, for accurate measurements these factors can be observed as given, or interpolated for other frequencies and added algebraically to the DBM dial readings. The formulas in par. 22 and 23 these corrections together with other factors pertinent to the accuracy of measurements.

**e. CONNECTING CORD CG-92A/U(8')**

(W101)

The eight foot RF transmission line Cord CG-92A/U(8') (W101) is used in all measurements that require connections to the RF connector on the front panel of the test set. A metal tag is attached to this cord with the insertion loss in db stamped thereon. The calibration of this cord should be performed frequently because of the unstable components of the type of coaxial cable of which this cord is constructed. An attenuation check is particularly important if the cord has been dropped, kinked, bent at sharp angles, handled roughly, or subjected to extremes in temperature. For the method of recalibrating this cord or any other similar cord, consult Section 5, par 9.

**5. PRELIMINARY CONNECTIONS AND ADJUSTMENTS.**

**CAUTION**

THE HIGH SENS SWITCH SHOULD EVER BE PUT IN THE MOMENTARY ON POSITION UNLESS FREQUENCY MEASUREMENTS OF SHORT DURATION RF SIGNALS ARE BEING MADE.

## OPERATION

## 4 Section Paragraph 5 a

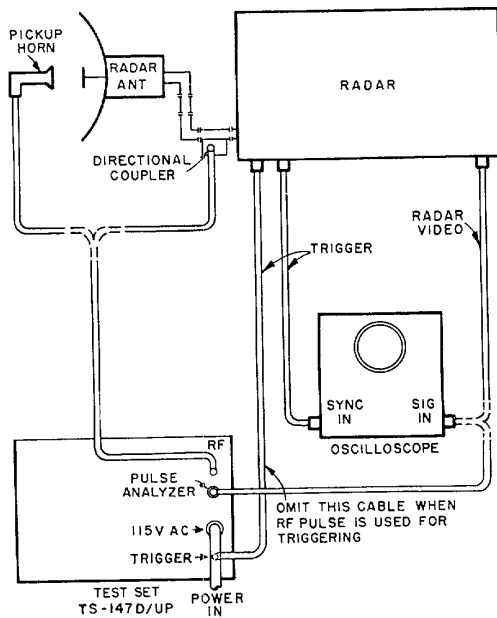

Figure 4-3. Operating Connection Diagram

### a. CONNECTIONS.

(See figure 4-3.)

(1) Attach cord CG-92A/U (8') (W101) between the RF connector on the front panel of the test set and the radar directional coupler or the Pick-up Antenna AT-68/UP (Z101). Put the TEST knob on TRAN and turn the DBM knob fully counterclockwise.

(2) Use power cord CX-337/U(6') (W102) to connect the 115v AC connector on the panel of the test set to a source of 115 volt, 59 to 1600 cps, power. Turn the 115v AC switch ON and wait for two minutes before operating the set.

(3) The following tests assume, unless otherwise specified, that the oscilloscope, radar, and test set are in operation as outlined in this paragraph and in par. 2, 3, and 4.

### b. FM OPERATION-TUNING THE TEST SET TO THE RECEIVER.

(1) The following tuning procedure is used in many of the FM tests given in this section. For the sake of brevity, it will not be repeated in the description of each test:

(a) An external trigger is not required unless the radar transmitter is not in operation, in which case a suitable external trigger must be supplied to the test set (at the TRIGGER connector) for FM operation.

#### Note

**DO NOT TRIGGER THE TEST SET SIMULTANEOUSLY FROM BOTH RF AND VIDEO TRIGGERS AS THIS WILL CAUSE ERRATIC OPERATION.**

(b) Adjust the radar receiver so that the AFC is on (if operative), and set the gain high enough to show small noise signals on the oscilloscope or radar indicator.

(c) Turn the TEST knob to the Red-Dot position (between TRAN and RECV).

(d) Turn the DBM dial to about -15 dbm.

(Appears as +15 dbm on dial.)

(e) Put the PHASE knob in mid-position.

(f) Turn the SIGNAL WIDTH to MIN.

(g) Set the EXT MOD-INT FM switch to

INT FM.

(h) Turn the SIGNAL FREQ knob and watch for the appearance of the signal on the scope.

(i) When the signal appears, turn the TEST knob to RECV and adjust the DBM knob to prevent saturation (See figure 4-9A.) and again adjust the SIGNAL FREQ knob for maximum signal.

(2) If no receiver signal is found on the scope over the range of the SIGNAL FREQ control (and the test set is known to be working properly), tune the radar receiver, as follows:

(a) Turn the AFC to manual.

(b) Adjust the local oscillator reflector or repeller voltage control to get maximum crystal current.

(c) If necessary, and as specified in the instruction book for the radar system, adjust the coupling to get crystal current.

(d) Tune for maximum target or echo box signal and simultaneous crystal current, using the local oscillator mechanical tuning.

(e) Readjust the reflector voltage when necessary to get crystal current. Repeat the steps in par. (2) (d) above.

(3) If test signals still cannot be seen, tune the receiver with the test set as outlined in par. 18.

### c. GENERAL OPERATING PROCEDURES.

(1) General functional operating procedures for using the test set as a frequency measuring device, a power measuring device, a CW signal generator, an FM signal generator, and a pulsed signal generator are given in figures 4-4, 4-5, 4-6, 4-7, and 4-8 respectively. These functions form the basis for performing all of the test procedures. Each specialized test is an application of one or more of the basic functions.

### 6. TEST 1A-TRANSMITTER AVERAGE POWER, $P_{av}$ , ABOVE +10 DBM.

(See figure 4-5.)

a. The average power is the product of the peak power of a single pulse multiplied by the duty cycle or ratio of the transmitter. The duty cycle is the fraction of operating time during which energy is actually

TABLE 4-2. FUNCTION OF CONTROLS AND CONNECTORS

NAME	TYPE	FUNCTION
HIGH SENS	Toggle Switch (Momentary)	Controls the sensitivity of the thermistor bridge. In the momentary ON position the thermistor bridge circuit has increased sensitivity. This increased sensitivity is used only when making frequency measurements of short duration RF pulses.
2 AMP SPARES TEST	Fuses Fuses Special Switch	The two fuses on either side of the power line. Two spare fuses for the power line. Opens and closes the wave guide to the test set oscillator and actuates a two position attenuator. In the TRAN position it cuts off the test set oscillator and sets the range of the DBM control at +7 to +30 dbm for transmitter power measurements. In the "Red-Dot" position the test set oscillator is on and the output power range is --7 to --45 dbm. In the RECV position the test set oscillator is on and the output power range is -42 to -85 dbm.
ON-OFF	Toggle Switch	115 volt AC power switch. In the ON position the test set is operating. IN THE OFF POSITION THE CABINET HEATERS ARE OPERATING.
POWER SET SIGNAL FREQ CRYSTAL	Special Special Crystal	Adjusts the initial power level of the test signal to balance the bridge. Tunes the klystron oscillator to the desired frequency. Detects RF pulses for use as a trigger for the test set oscillator or for RF pulse envelope observation.
DBM	Attenuator	Adjusts the level of input or output power. The dial is calibrated in dbm.
FREQUENCY	Tunable Cavity	Tunes the frequency meter. The thermistor bridge meter is used as the resonance indicator for the frequency meter. The frequency meter dial readings must be multiplied by ten to get the frequency.
RF	Type "N" Connector	RF input and output connector.
MOD AMP	Variable Resistor	Varies the voltage of a pulse applied to the EXT MOD connector to vary the frequency of the output pulse.
PULSE ANALYZER	"BNC" Connector	For use with an oscilloscope to view the envelope of an RF pulse.
115V AC SET ZERO- FINE AND COARSE	Connector Variable Resistors	Power line connector. Adjusts the current through the thermistor bridge to set the bridge meter reading to SET ZERO.
SIGNAL WIDTH PHASE	Variable Resistor Variable Resistor	Sets the amplitude of the sawtooth sweep applied to the klystron and therefore the amount of FM from zero (CW) to over 40 mc. Controls the DC reflector voltage of klystron oscillator tube. Adjusts time delay between trigger and center frequency of test signal. When the SIGNAL WIDTH control is set at CW, it selects the operating mode of the oscillator.
EXT MOD- INT FM	Toggle Switch	Selects either external modulation for pulses applied at the EXT MOD connector or internal modulation (FM or CW) of the test set.
EXT MOD	"BNC" Connector	Connector for coupling pulses to the test set for pulse modulating the oscillator.
TRIGGER	Connector	Connector for coupling video pulses to the test set for triggering the FM sweep.

**NOTE: The meter over the SET ZERO controls is used for the frequency meter resonance indicator and for establishing a reference power level in the thermistor bridge circuit.**

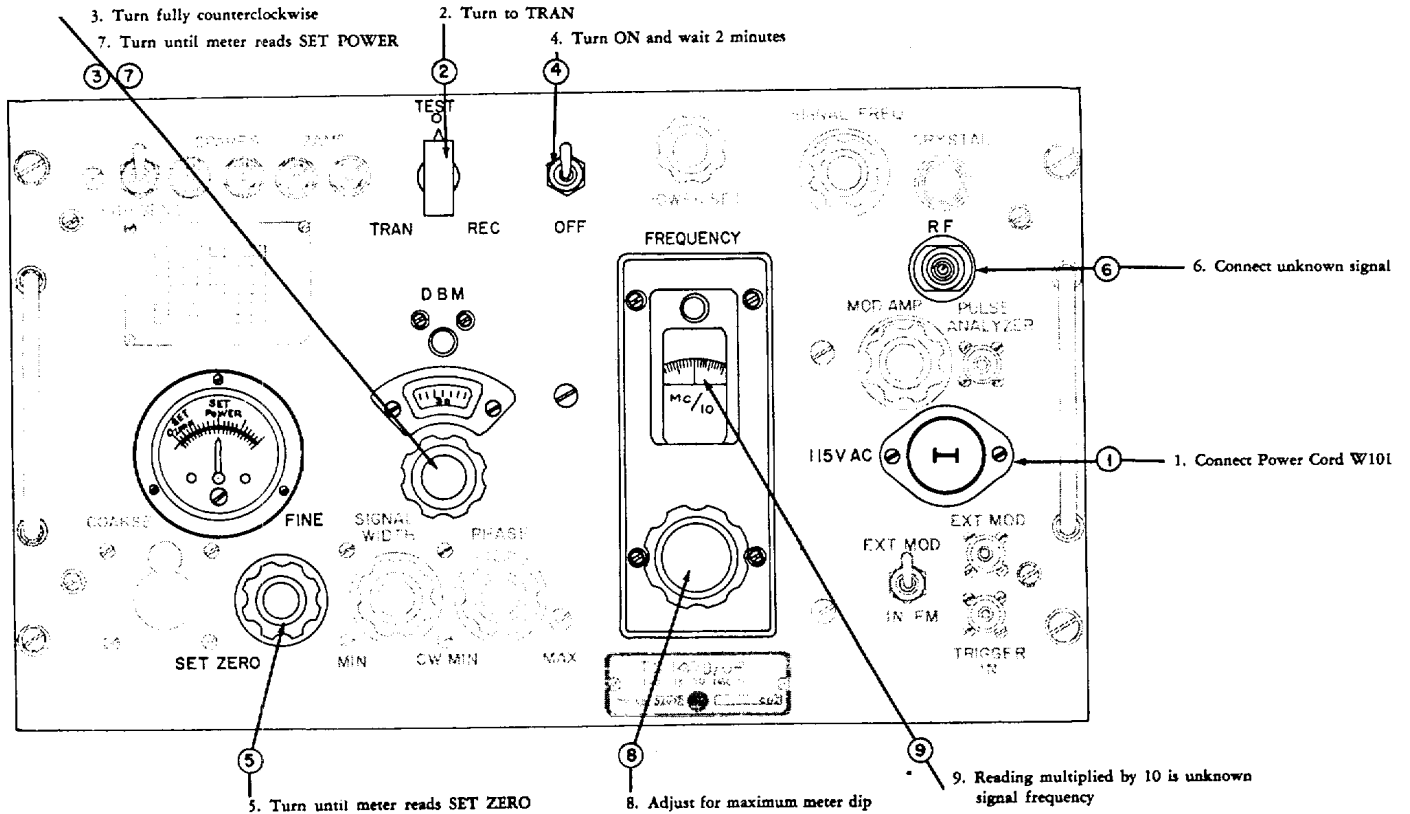

Figure 4-4. Simplified Procedure for Operating Test Set TS-147D/UP as a Frequency Measuring Device

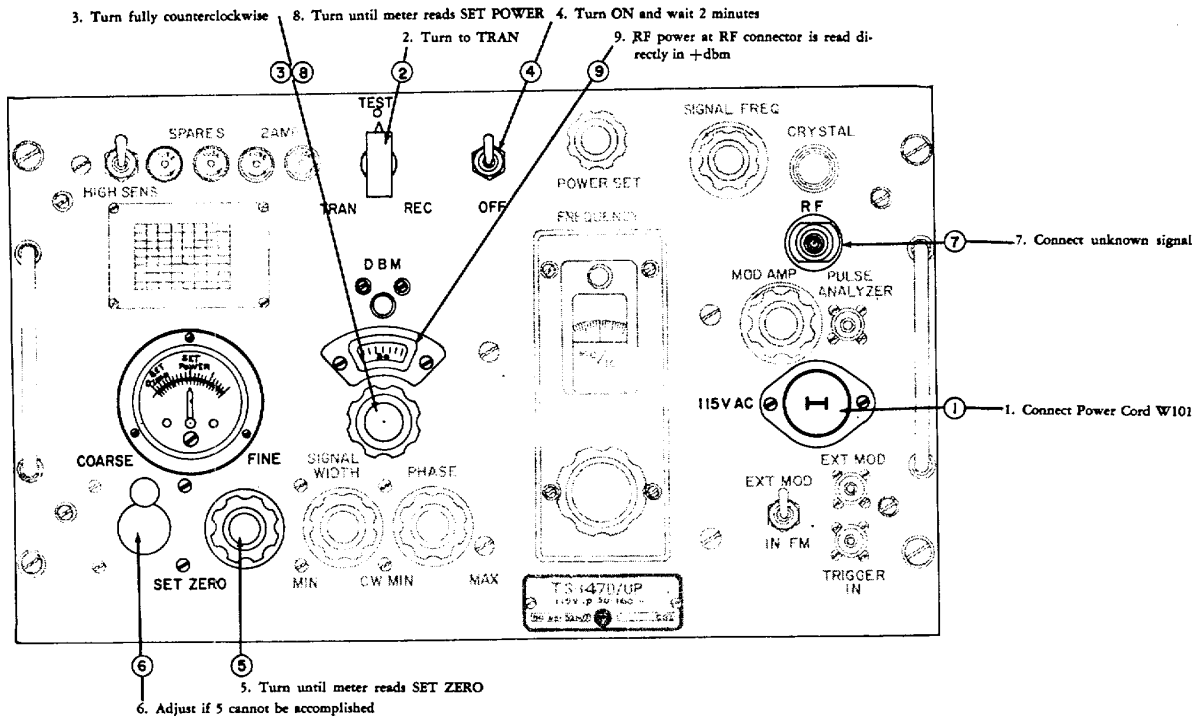

Figure 4-5. Simplified Procedure for Operating Test Set TS-147D/UP as a Power Measuring Device

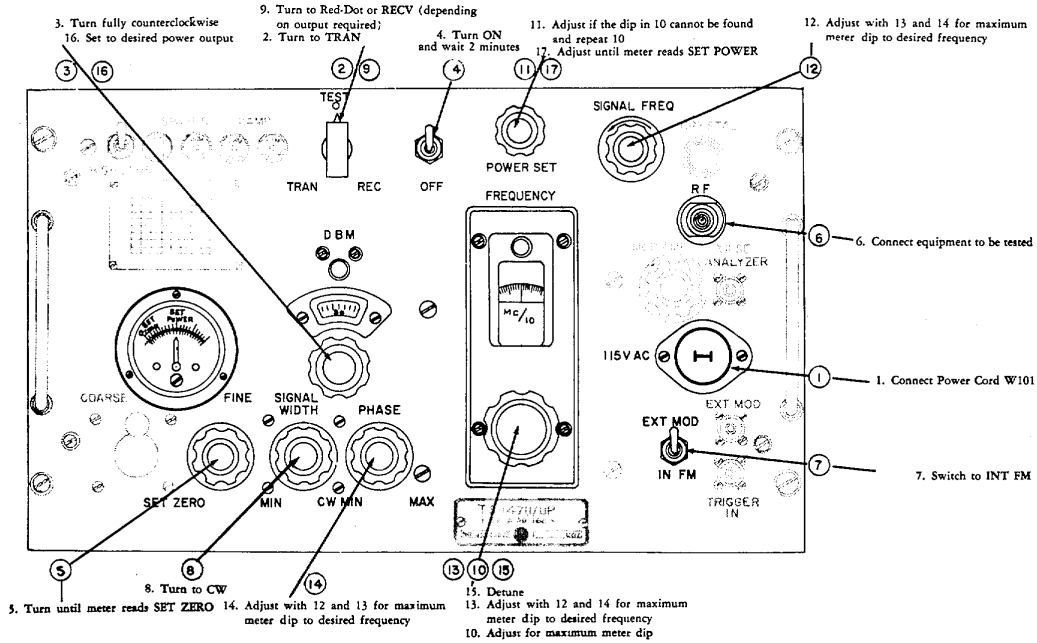

Figure 4-6. Simplified Procedure for Operating Test Set TS-147D/UP as a CW Signal Generator

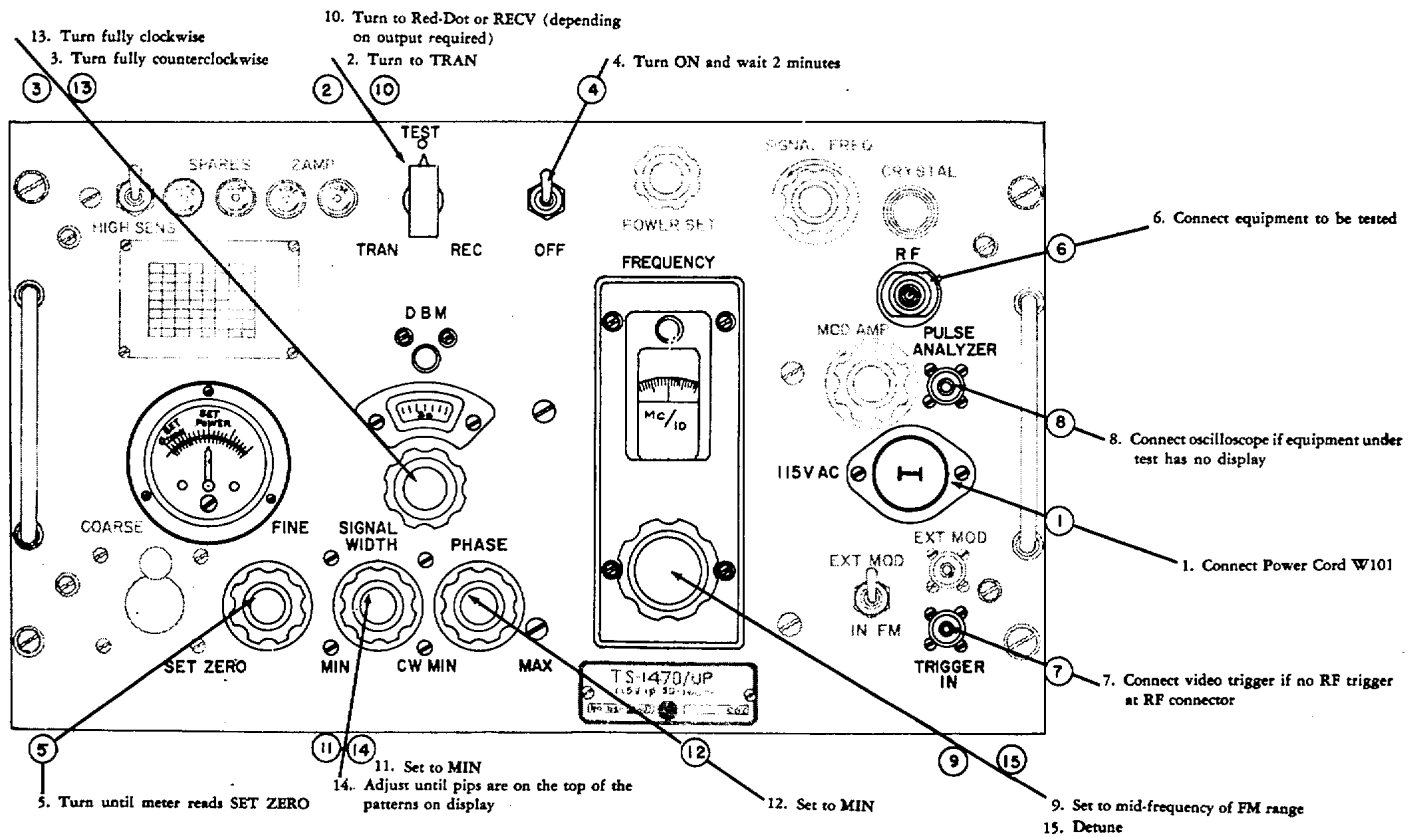

Figure 4-7. Simplified Procedure for Operating Test Set TS-147D/UP as a FM Signal Generator



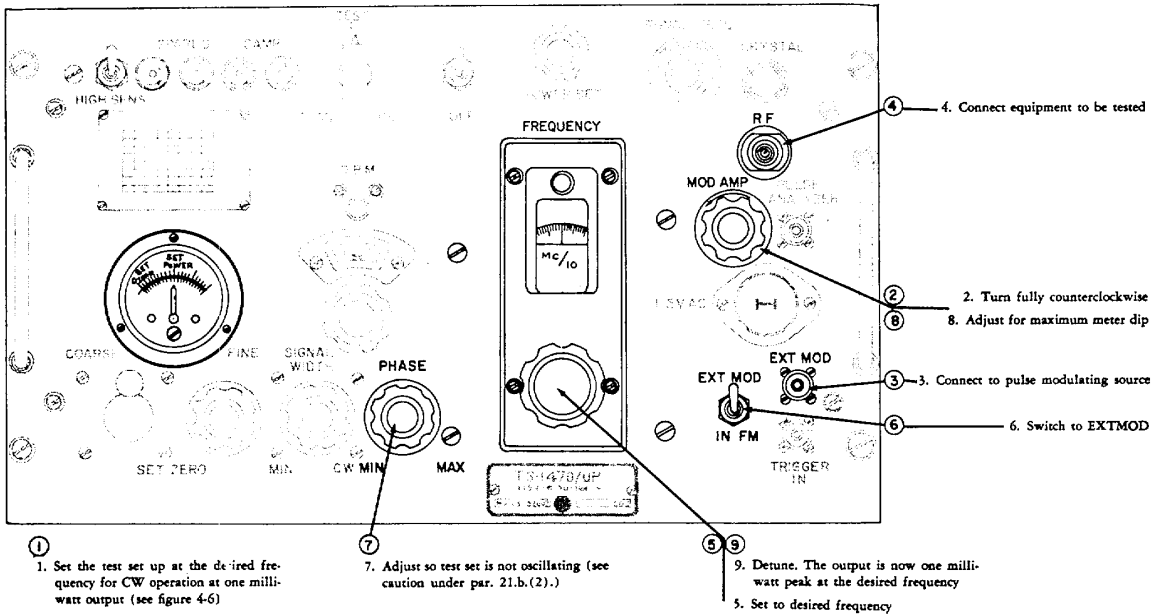

Figure 4-8. Simplified Procedure for Operating test Set TS-147D/UP as a Pulsed Signal Generator

being transmitted and is equal to the pulse recurrence frequency (PRF) multiplied by the length of duration of the pulse. If the power is on 1000 of the time (CW), the equivalent PRF is one, with an equivalent pulse length of one million microseconds. Thus the Pulse Length X PRF equals the virtual pulse length at a PRF of 1 or the Duty Cycle.

Example # 1:

PRF = 1000 (pulses per sec)

Pulse length = 2 microseconds

In one second the power is on for 2000 u sec or 0.002 sec. The duty cycle therefore is 0.002 or 1/500, which means:

The average power is 1/500 of the peak power; or  
The peak power is 500 X average power.

Example #2:

PRF = 1000

Pulse length = a group of 3 one u sec pulses Power is on for 1000 X 3 = 3000 u sec per sec.

Duty Cycle = 3000 u sec per sec

1000000 u sec per sec

= 0.003 which means:

That the full power is on 3 of the time; and  
1000

The average power is 3/1000 or 1/333 of the peak power; or

The peak power is 333 X average power.

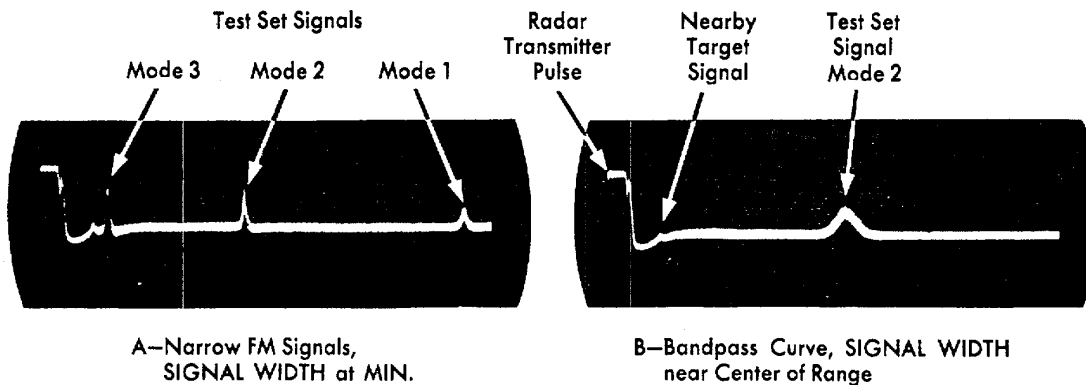

Figure 4-9. Frequency Modulated Test Set Signals

## OPERATION

b. The test set measures the average power directly by means of the thermistor bridge and the attenuators. It will indicate accurately the level delivered at the RF connector on the front panel. Since there is a power loss between the RF connector and the radar antenna, this must be compensated for in order to ascertain the correct power at the radar antenna. There is the space and antenna loss if the pick-up antenna is used or the directional coupler loss (usually about 20 db) if used in place of the pick-up antenna, plus the attenuation in the connecting cord. Any correction factor for the DBM attenuator must be added or subtracted as the case may be:

(1) Adjust the wattmeter (See par. 4b (2).)

(2) Turn the DBM dial clockwise until the meter pointer is on the SET POWER mark.

### CAUTION

**IN MEASURING POWER, THE TEST SET FREQUENCY METER MUST BE TUNED OFF THE FREQUENCY OF THE RECEIVED RADAR SIGNAL, BECAUSE AT RESONANCE IT ABSORBS PART OF THE SIGNAL, CAUSING INACCURACY.**

c. Record the plus reading of the DBM dial. This is the average RF power at the RF connector of the test set in db above one milliwatt.

d. Use formula 1, par. 22 to compute  $P_{av}$ , the transmitter average power.

e. Compare  $P_{a,r}$  with the value at which the radar is rated. If the rated value is given in watts, it may be converted to dbm by using the curve in figure 4-18. If the rated peak power is the only value known, this may be converted to rated average power by using the computation described in par. 25.

## 7. TEST 1B-TRANSMITTER AVERAGE POWER, $P_{AV}$ BELOW +10 DBM.

a. When transmitter power entering the set is between + 1 and + 10 dbm, the following procedure may be used:

(1) Adjust the wattmeter (See par. 4b (2).);

(2) Turn the DBM dial fully clockwise, then set it carefully to + 10 dbm;

(3) Read the meter to get power entering the test set in milliwatts. Each division on the meter dial represents an increment of approximately one milliwatt, the SET ZERO point is zero milliwatts, and the SET POWER point is ten milliwatts.

### CAUTION

**THE TEST SET FREQUENCY METER MUST BE TUNED OFF THE FREQUENCY OF THE RECEIVED RADAR SIGNAL, OTHERWISE A PORTION OF THE POWER WILL BE ABSORBED.**

(4) Use figure 4-18 to convert the value for power entering the test set from milliwatts to dbm. Use this value (in dbm) for  $T(\text{dbm})$  in formula 1, par.

## Section 4

### Paragraph 6 b

22, to get  $P_{av}(\text{dbm})$  the transmitter average power in decibels above one milliwatt.

## 8. TEST 2-TRANSMITTER FREQUENCY, $f_t$ .

(See figure 4-4.)

a. For maximum efficiency, the signals transmitted by a radar must be at the frequency to which the radar receiver is tuned. The FREQUENCY dial of the test set, directly linked to the plunger of the frequency meter cavity, indicates directly in megacycles /10 (tens of megacycles) the frequency to which the frequency meter is tuned:

(1) Adjust the wattmeter (See par. 4b(2).)

(2) Turn the DBM dial clockwise (reducing the attenuation on the incoming signal) until the meter pointer is at the SET POWER mark;

(3) Turn the FREQUENCY dial carefully to maximum dip of the bridge meter, making the final approach counterclockwise to minimize the effects of backlash. Record the FREQUENCY dial reading and multiply it by ten to convert it to the frequency in megacycles.

### Note

**WHEN MEASURING PULSED RF SIGNALS OF SHORT DURATION IT MAY BE FOUND THAT THE METER DOES NOT DIP SUFFICIENTLY TO INDICATE THE FREQUENCY. IF THIS IS SO, HOLD THE HIGH SENS SWITCH IN THE MOMENTARY ON POSITION AND AGAIN TURN THE FREQUENCY KNOB UNTIL A DIP IS OBSERVED.**

### CAUTION

**THE FREQUENCY METER HAS AN INHERENT FALSE SECONDARY MODE ABOUT 600 MC LOWER ON THE DIAL THAN THE PRIMARY MODE. THIS SECONDARY MODE GIVES A MUCH SMALLER DIP AND IS ABOUT FOUR TIMES AS WIDE AS THE DESIRED MODE. THE SECONDARY MODE MUST BE AVOIDED, WHEN MEASURING FREQUENCIES ABOVE 9000 MC.**

## 9. TEST 3-RECEIVER FREQUENCY, $f_r$ .

a. For maximum efficiency, a radar set receiver must be tuned to the frequency upon which the set is transmitting. The FREQUENCY dial reads directly in tens of megacycles. For tuning the radar receiver (local oscillator tuning) see par. 18.

b. Tune the test set to the receiver. (See par. 5b.)

c. Turn the SIGNAL WIDTH and PHASE knobs until the bandpass curve occupies about one-third of the screen width.

d. Adjust the FREQUENCY control so that the dip (showing the frequency to which the frequency meter is tuned) is on the top of the bandpass curve. (See figure 4-IOA.) Record the reading and multiply it by ten to get the radar receiver frequency,  $f_r$ , in megacycles

Since there are two frequencies which differ from the local oscillator (of the radar set) by the intermediate frequency, the frequency just found may differ from  $f_t$  (the transmitter or beacon frequency) by a factor of twice the intermediate frequency. If this is so, repeat the steps in this test, using the alternative signal (the beacon or transmitter frequency). (Clockwise rotation of the SIGNAL FREQ knob decreases the frequency.) If the frequency found still differs from the transmitter (or beacon) frequency, or is unsteady, AFC trouble is indicated. Look for defects in:

- (1) Local oscillator tuning; (See par. 18.)
- (2) Discriminator tuning;
- (3) AFC circuit;
- (4) Shock excitation of the first IF stage (AFC);
- (5) Faulty magnetron or improper transmitter tube voltages;
- (6) Defective plumbing.

**10. TEST 4-RECEIVER BANDWIDTH MEASUREMENT.**

a. In general, short range radars (such as fire-control units) require a wide band response, and long range

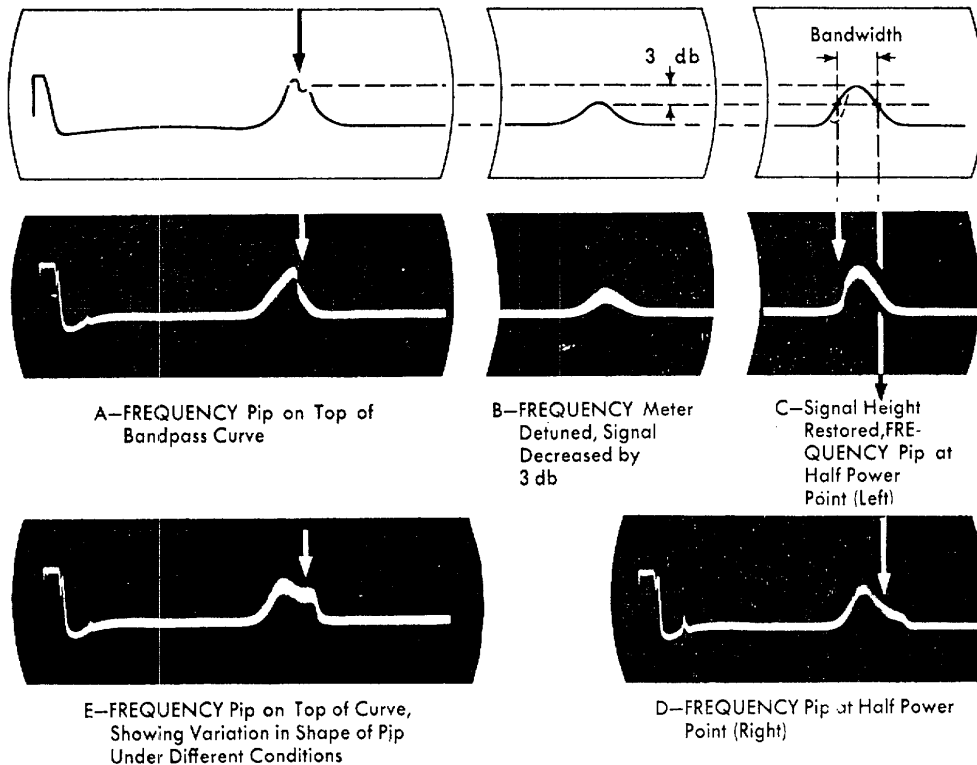

Figure 4-10. Receiver Frequency and Bandwidth Measurements

radars (such as early warning systems) require a narrow band response. The optimum bandwidth for a particular radar depends, among other factors, upon the function of the set: (See the instruction book for the radar under test.)

(1) Measure the receiver frequency,  $f_r$ , as in par. 9.

(2) In this test it is convenient to use the half-power height of the pulse. To get this height, increase the setting of the DBM meter by 3.0 dbm (making sure the FREQUENCY control is detuned) thus cutting

the power level at the receiver in half. Mark the half-power height (See figure 4-10.) and restore the DBM dial to its original setting.

(3) Move the FREQUENCY pip across the curve by turning the FREQUENCY knob and observe the frequency readings at the two points where the pip goes through the half-power line established in par. 10a(2). The frequency difference between the two points is the receiver bandwidth.

$$\text{Bandwidth: } B = f_1 - f_2$$

(4) Occasionally, when the frequency meter pip is tuned within the passband, the response curve on the oscilloscope is distorted so that it is difficult to set the positions of the frequency meter pip to the half-power points with accuracy. An alternative procedure is to calibrate the horizontal sweep in megacycles per inch and to measure the distance, and hence the frequency, directly between the two half-power points.

(5) To calibrate the horizontal sweep, measure the frequency at any two convenient points as far apart as possible on the response curve and mark these points on the scope. Measure the distance between these two points in inches using a pair of dividers and a scale graduated in hundredths of an inch if these are available. Divide the difference between the two frequencies by the distance in inches just obtained. The resulting calibration will be in megacycles per inch. This calibration is dependent upon the settings of the SIGNAL WIDTH and PHASE controls. Therefore, the setting of these knobs must not be changed after the calibration is made.

**11. TEST 5-RECEIVER PERFORMANCE FIGURE,  $P_m$  (SENSITIVITY), USING FM.**

a. Receiver sensitivity is expressed in -dbm (decibels below one milliwatt) and is a measure of the power of the weakest signal discernible on the radar scope. Receiver sensitivity,  $P_m$ , is found as the test set output (at the RF connector), less the power loss between the connector and the radar antenna owing to attenuation in the cable and the directional coupler or pick-up antenna loss, of the weakest signal discernible on the scope: (See par. 23.)

(1) Check the receiver frequency (see par. 9.), unless it is known that the radar receiver is tuned to its transmitter.

(2) Turn the radar AFC on (if operative) and set the radar receiver gain to show a part of the transmitter pulse and the noise.

(3) Tune the test set to the receiver. (See par. 5b.)

(4) Adjust the test set wattmeter (See par. 4b(2).)

(5) Turn the TEST knob to the RECV position, and turn the DBM knob clockwise. The FM signal will again appear on the scope.

(6) Broaden the bandpass curve to maximum by turning the SIGNAL WIDTH control clockwise to CW while at the same time turning the PHASE knob to hold the pattern on the screen. Detune the frequency meter.

(7) Adjust the POWER SET knob until the meter reads SET POWER.

(9) Turn the DBM attenuation control until the test set signal just disappears in the noise. (See figure 4-11. At the point where the signal just disappears, turn the knob in one-dbm steps and move the signal

back and forth with the PHASE knob in order to see it. At the last step where the signal is visible, record the reading of the DBM dial.

(10) Use formula 2 (See par. 23.) to find the Receiver Performance Figure  $P_m$  (dbm)

(11) The rated value for the receiver performance (see the radar instruction book) may be converted to dbm by using the chart, figure 18.

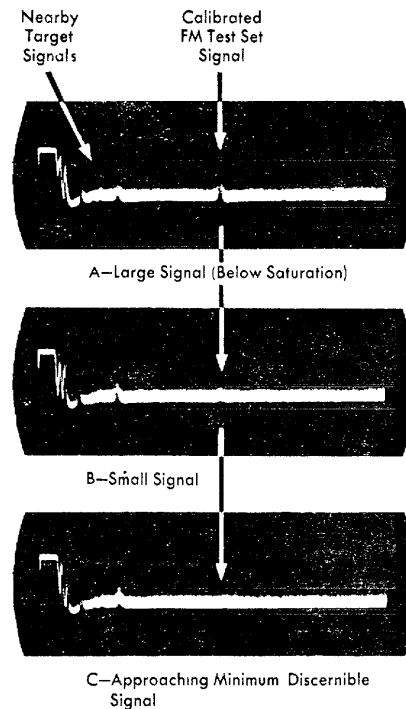

Figure 4-11. Measuring Minimum Discernible Signal Power

**12. TEST 6-CW SIGNAL EQUAL TO NOISE.**

**Note**

**THE "CW SIGNAL EQUAL TO NOISE" TEST IS A MEASUREMENT USED IN BENCH-TESTING RECEIVER SENSITIVITY. IT IS RELATED TO, BUT NOT EQUAL TO, THE RECEIVER PERFORMANCE FIGURE, (MINIMUM DISCERNIBLE SIGNAL POWER) USED IN FIELD MEASUREMENTS.**

a. Connect a voltmeter (20,000 ohms per volt sensitivity from ground to the cathode of the second detector tube of the radar receiver.

c. Check the balance of the test set wattmeter. (See par. 4b(2).)

d. Calibrate the second detector:

(1) Put the TEST knob on RECV and turn the DBM knob clockwise until the meter indicates power.

(2) Broaden the bandpass curve to a maximum by turning the SIGNAL WIDTH control clockwise to CW while at the same time turning the PHASE knob to hold the pattern on the screen. Detune the FREQUENCY meter.

(3) Adjust the POWER SET knob so that the meter reads SET POWER.

(4) Turn the radar receiver gain down, and then bring it up again until the "second detector" voltmeter first shows deflection.

(5) Turn the DBM dial in one-db steps. Record the DBM dial readings and the corresponding readings of the "second detector" voltmeter. Plot the DBM dial readings against the voltmeter deflections on graph paper. (As an approximation, this calibration of voltmeter readings vs dbm may be assumed to be a constant for all radars of the same type.)

e. With the DBM dial set for maximum attenuation, turn the receiver gain to a convenient level (less than half of saturation) and observe the reading of the "second detector" voltmeter.

f. Measure the CW signal equal to noise:

(1) Find the meter reading from the calibration curve (See par. 12d(5).) for a value of 3 db above the noise level obtained in par. 12e;

(2) Adjust the DBM dial to restore the CW signal as it was at the beginning of the test. (See par. 12d.) Then further adjust the DBM dial until the "second detector" voltmeter reads as in par. 12e. Record the reading of the DBM dial.

g. The formula by which CW signal equal to noise is computed is similar to formula 2 (See par. 23.) except that the value for  $M_{(dbm)}$  is positive, and  $P_{m(dbm)}$  becomes the  $P_{new(dbm)}$ , which equals the continuous wave power input (to the radar) that produces a power level equal to noise at the second detector. (See formula 2, par. 23.)

### 13. TEST 7A-TR RECOVERY TIME, USING FM.

a. During each transmission from a radar, a TR (Transmit-Receive) Switch prevents most of the transmitted signal from entering the receiver channels and blocking them. The time between the beginning of the transmitted pulse and the opening of the receiver channels again, by the TR switch, is the TR switch recovery time. If it is too long, responses from nearby targets may be blocked from the receiver:

(1) Tune the test set to the receiver; (See par. 5b.)

(2) Leave the radar AFC on, if operative, and adjust the gain for small noise signals. Adjust the test set DBM knob until the signal height is about half-way between noise and saturation;

(3) If present, the blanking pulse must be made inoperative; (See the radar set instruction book.)

(4) Move the signal towards the transmitter pulse by turning the PHASE knob counterclockwise toward MIN until the signal height starts to decrease. Then measure the range in microseconds of delay from the trailing edge of the transmitter pulse to the signal. This is the receiver recovery time, often referred to as the TR recovery time; (Do not confuse with TR switch recovery time.)

(5) From the instruction book for the radar set get the transmitter pulse length. The recovery time of the TR switch is the sum of the pulse length and the delay as measured above. (See par. (4) above.)

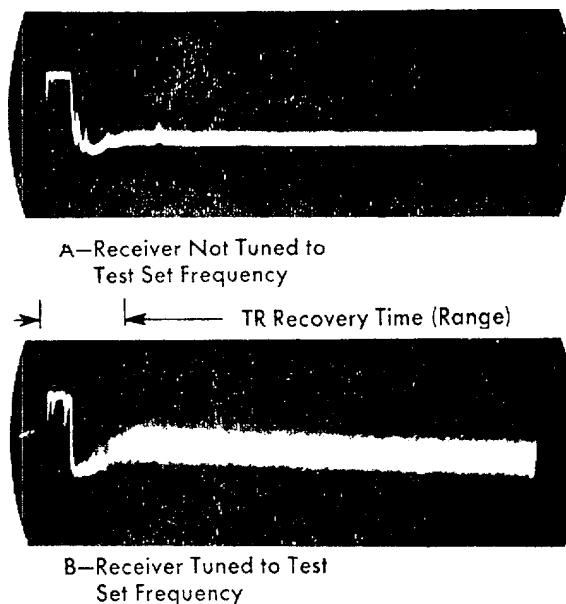

Figure 4-12. Receiver Tuning on CW and Alternate Method of Checking TR Recovery

### 14. TEST 7B-TR RECOVERY TIME, USING CW.

a. The following CW procedures are useful in special cases where the TR recovery time is short and it is not possible to phase the signal all the way into the transmitter pulse:

(1) Tune the test set to the receiver. (See par. 5b.)

(2) If present, the blanking pulse must be made inoperative. (See the radar set instruction book.)

(3) Detune the FREQUENCY meter. Turn the SIGNAL WIDTH knob clockwise to CW while holding the signal in sight with the PHASE knob.

(4) Note the point at which the signal begins to distort and measure TR recovery time as in par. 13a (4) and 13a (5).OR

(5) Perform Test 5, par. 11a (1) through par. 11a (9).

(6) Tune the SIGNAL FREQ knob for maximum signal height (See figure 4-12) keeping the signal below saturation.

## OPERATION

(7) The T'R recovery time is indicated by the range (time) at which the noise ("grass" height) starts to decrease (See figure 4-12B).

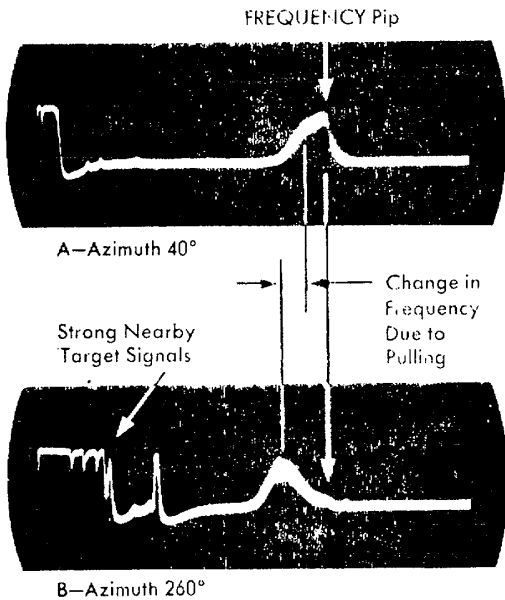

Figure 4-13. Checking Receiver Pulling and AFC Tracking

### 15. TEST 8-TRANSMITTER PULLING AND AFC TRACKING.

a. Transmitter pulling and faulty operation of the automatic frequency control circuits may cause periodic or random variations in frequency during operation of a radar:

(1) Tune the test set to the receiver. (See par. 5b.)

(2) Turn the PHASE knoll clockwise to put the signal near the center of the screen. Broaden the signal by turning the SIGNAL WIDTH knob partly clockwise. Set the FREQUENCY meter so that the pip is on top of the curve.

(3) Start the radar antenna. If the FM signal moves on the scope (See figure 4-13), transmitter pulling is indicated. It may be caused by faulty housing, bad rotating joints, etc. If the signal remains stationary on the screen, the AFC is tracking all right.

### 16. TEST 9-BEACON RESPONSE OF RADAR.

a. Most radars have a different pulse length and repetition frequency on beacon operation. Tests of beacons are similar to those on other radars:

(1) Switch the radar to BEA(CON and measure the crystal current, the rectifier current, and the modulator current. (See radar set instruction book.)

(2) Make Test 1 (See par. 6 or 7.) to determine transmitter average power.

## Section 4

### Paragraph 14 a (6)

(3) Make Test 2 (See par. 8.) to measure transmitter frequency.

(4) If there is no beacon or tuning cavity, tune the beacon receiver as in par. 18. Then perform Test 3. (See par. 9.) substituting the beacon for the transmitter frequency, to determine the receiver frequency for reception of the beacon signal.

(5) Follow the procedure of Test 5 (See par. 11.) to get the receiver performance figure for beacon reception.

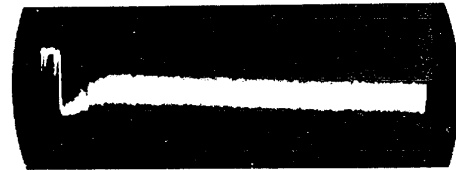

Figure 4-14. CW Jamming

### 17. SYNTHETIC TARGET.

a. GENERAL.-The test set may be used with FM in conjunction with the PHASE control to produce a synthetic target. (See par. 10, 11.) This is accomplished by sweeping the RECV passband. A trigger from the radar may be connected to the TRIGGER connector, or the RF signal itself may be made to sweep the oscillator. A close or distant target can be simulated by adjusting the PHASE control.

### 18. RADAR RECEIVER TUNING, USING FM.

a. This procedure is for use where automatic frequency control (AFC) is absent, or when the results of Test 3, (See par. 9.) are not satisfactory.

b. The receiver may be tuned with the frequency of the receiver local oscillator either above or below the transmitter frequency and differing from it by the intermediate frequency (the IF is usually 30 or 60 megacycles per second). It is important that the local oscillator be on the correct side of the transmitter frequency, as specified in the radar instruction book. In most radars, the local oscillator is at the intermediate frequency above the transmitter frequency. To check whether it is above or below, tune the local oscillator until the two tuning points at which the signals appear on the oscilloscope are found. The radar instruction book indicates which direction of rotation of the local oscillator frequency control increases the frequency. Since one of the two tuning points is below the transmitter frequency and the other is above, this information indicates which of the tuning points is the desired one

Radar <u>AN/RPS-15A</u> Serial No. <u>1725</u>		Observer <u>FBI</u>	Date <u>2/15/49</u>		
	<b>SEARCH</b>				
	Preliminary Procedure	Radar Modulator Current	.....	<u>7.5</u> ma	
		Radar Rectifier Current	.....	<u>9.0</u> ma	
		Radar Crystal Current	.....	<u>0.6</u> ma	
	Transmitter Average Power	DBM Dial Reading	.....	<u>+17.5</u> dbm	
		Cable Attenuation	..... A	<u>4</u> db	
		Coupling	..... C	<u>20</u> db	
		Total	..... P <sub>A</sub>	<u>+41.5</u> dbm	
		Rated	.....	<u>+44.5</u> dbm	
		Difference	.....	<u>-3</u> db	
	Transmitter Frequency	Reading	<u>936.5</u>	Frequency	..... f <sub>1</sub> <u>936.5</u> Mc
	Receiver Frequency	Reading	.....	<u>936.6</u>	
		Frequency	.....	f <sub>2</sub> <u>936.6</u> Mc	
	Receiver Bandwidth	Readings (1)	<u>936.5</u>	(2)	<u>936.7</u>
		Bandwidth, f <sub>1</sub>	<u>936.5</u>	f <sub>2</sub>	<u>936.7</u> B
				<u>2</u> Mc	
Receiver Performance Figure (Sensitivity)	DBM Dial Reading	.....	<u>-69</u> dbm		
	Cable Attenuation	..... A	<u>-4</u> db		
	Coupling	..... C	<u>-20</u> db		
	Total	..... P	<u>-93</u> dbm		
	Rated	.....	<u>-95</u> dbm		
	Difference	.....	<u>+2</u> db		
Overall Performance	Differences (b)	<u>-3</u> db	..... (f)	<u>+2</u> db	
	Overall Difference	..... (b-f)	<u>-5</u> db		
TR Recovery	Range	.....	<u>0.2</u> miles		
Transmitter Pulling; AFC Tracking	Transmitter Pulling: No <input checked="" type="checkbox"/> Yes <input type="checkbox"/>				
	AFC Tracking: Good <input checked="" type="checkbox"/> Poor <input type="checkbox"/>				
Beacon Response of Radar	Receiver Tuning				
Maintenance Notes:					

Figure 4-15. Sample Radar Performance Data Sheet

## OPERATION

If only one can be found, the other tuning point is outside the range of the local oscillator and the first is, necessity, the one to be used. The beacon local oscillator in a radar is usually at the intermediate frequency below the beacon frequency.

c. Put the radar on manual tuning and set the receiver gain high enough to show small noise signals on the scope.

d. On the test set, put the TEST knob to RECV, the DBM knob at about -50 dbm, the POWER SET knob near maximum attenuation (fully counterclockwise), and the PHASE knob near its mid-position.

e. Tune the receiver to the transmitter (or beacon) frequency as follows:

(1) Turn the test set SIGNAL WIDTH knob clockwise to CW.

(2) Obtain the greatest meter reading with the PHASE control. Adjust the POWER SET knob until the meter reads SET POWER. Leave the TEST knob on RECV.

(3) Adjust the SIGNAL FREQ knob to the transmitter (or beacon) frequency, resetting the PHASE knob when the meter drops as much as ten per cent. The frequency is checked by watching for a dip in the meter reading when the FREQUENCY meter is tuned to the transmitter (or beacon) frequency.

(4) Turn the SIGNAL WIDTH knob to MIN and the TEST knob to the Red-Dot position.

(5) On the radar, put the local oscillator at the extreme end of its tuning range and on the correct side of the transmitter (or beacon) frequency, as specified in the radar instruction book. Adjust the local oscillator for crystal current.

(6) On the radar, tune the receiver local oscillator mechanical tuner slowly toward the center of its range, re-setting the reflector voltage when the crystal current drops, and watching for the FM signal on the oscilloscope. Tune the mechanical tuner of the receiver for maximum FM signal and maximum crystal current.

(7) On the test set put the TEST knob on RECV and adjust the DBM attenuator, if necessary, to prevent saturation.

(8) Carefully broaden the SIGNAL WIDTH control while holding the signal in view with the PHASE control until the bandpass curve is obtained. Then adjust the radar local oscillator to get the frequency pip on top of the curve. (See figure 4-10A.)

f. Tune the TR and anti-TR for maximum test set signal. (While tuning, adjust the test set DBM attenuator to avoid saturation of the signal.) Adjust the crystal current for proper value. Re-adjust the local oscillator, TR, and anti-TR to compensate for interaction.

g. Switch the radar to AFC. If the pattern moves more than a few megacycles in frequency, adjust the AFC discriminator secondary. If the pattern disappears altogether on AFC, either the AFC is inoperative or the manual tuning is on the wrong side of the transmitter frequency.

## 19. SPACE LOSS WITH PICK-UP ANTENNA.

a. Space loss of the pick-up antenna is measured by comparison with the loss in a directional coupler. Therefore, this measurement can be easily made only on a radar system in which a directional coupler is used or when a directional coupler can be obtained temporarily. Once the space loss for a particular type of system is determined, it is unlikely that the measurement will have to be repeated for each system of the same type, provided the same antenna location is always used and that the distance chosen is not critical.

b. To assure that the antenna is placed at the least critical location, set the pick-up antenna at a point where a change of position of a given antenna produces a minimum change in the amount of the reading. This will usually occur when the pick-up antenna is placed between three and five feet away from the radar antenna and located at a maximum power point of the antenna pattern.

c. Connect the test set as shown in Figure 4-3, first using the directional coupler and then the pick-up antenna. In each case, measure the transmitter average power  $P_{AV}$  (See Test 1A, par. 6.) and record the results.

d. The loss (space loss plus antenna, transmission, line, etc. loss) for the pick-up antenna in conjunction with the particular radar system, is the difference between the DBM dial reading when connected to the directional coupler and the DBM dial reading when using the pick-up antenna, added to the db value of the directional coupler.

## 20. PULSE ANALYZER.

a. The rectified envelope of an RF pulsed signal can be viewed on an oscilloscope. This is accomplished by connecting the RF signal to the RF connector on the test set and connecting the oscilloscope video (or vertical) input connector to the PULSE ANALYZER connector on the test set.

## 21. EXTERNAL MODULATION.

(See figure 4-8.)

a. GENERAL.-The following procedure is used to produce RF pulsed signals in the test set. The modulating pulses must have a rise time not greater than 0.5  $\mu$ s and 50 volts amplitude if of positive polarity.

### CAUTION

### THE REPELLER OF THE KLYSTRON OSCILLATOR MUST NEVER BE ALLOWED TO GO POSITIVE.

(1) Set the test set up at the desired frequency for CW operation, see paragraph 4.c;

(2) Turn the POWER SET knob until there is no power indication;

(3) Connect the test set EXT MOD connector to a pulse generator that will produce the desired pulse characteristic with no more than 50 volts peak amplitude. Connect the signal generator synchronizing pulse to a scope sync input. Connect the PULSE ANALYZER connector to the oscilloscope vertical input;



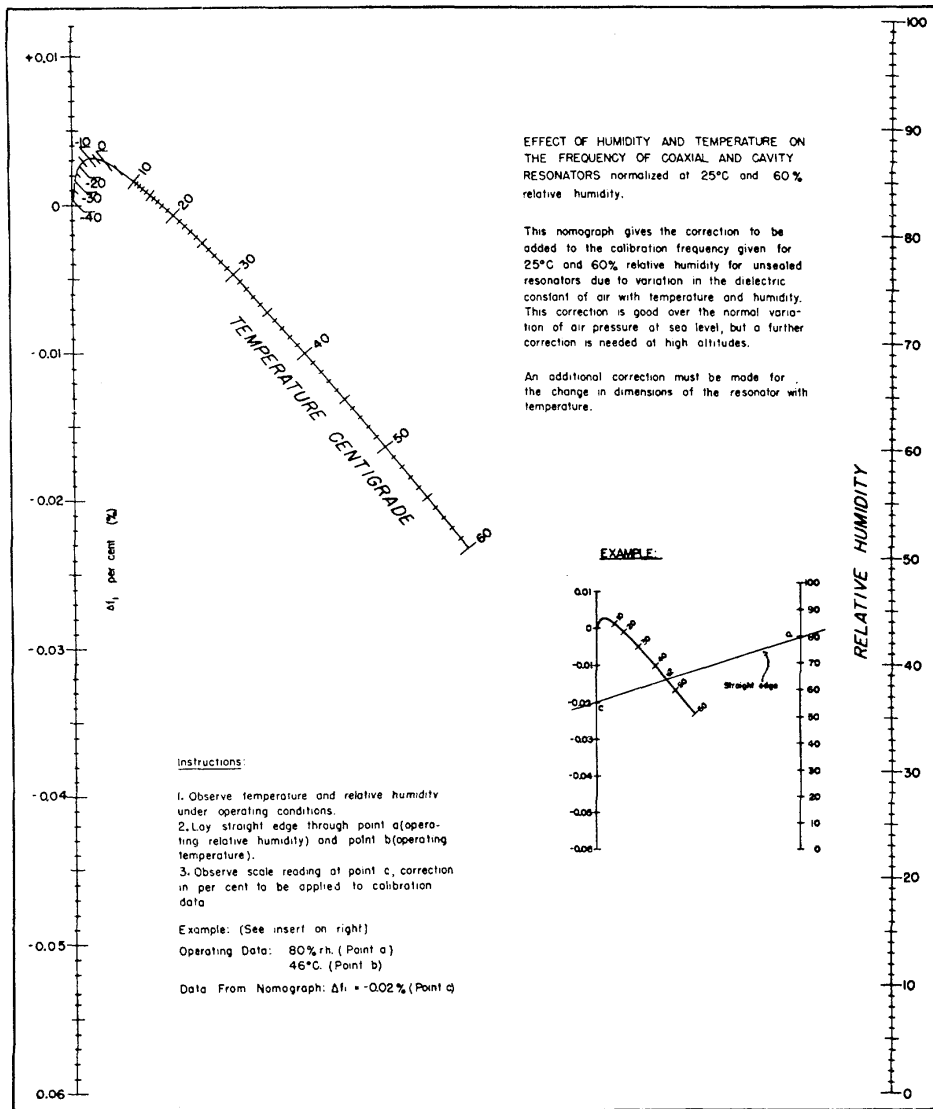

Figure 4-16. Frequency Meter Corrections for Dielectric Changes Due to Temperature and Humidity

**OPERATION**

**Section 4  
Paragraph 21 a (4)**

- (4) Set the MOD AMP control full counterclockwise;
- (5) Set the INT FM-EXT MOD switch at EXT MOD;
- (6) Turn the MOD AMP control until a pulse appears on the oscilloscope;
- (7) Adjust the PHASE control for the best shape and amplitude of pulse;
- (8) There is now an RF pulse available at the RF connector.

b. CALIBRATED PULSE.-The following procedure is used to produce RF pulsed signals of known frequency and power in the test set.

- (1) Connect the equipments as in (3) above;
- (2) Adjust the test set to 1 milliwatt output at the desired frequency for CW conditions;

**CAUTION**

**CARE MUST BE TAKEN WHEN ADJUSTING THE PHASE CONTROL. FOR A POSITIVE PULSE, THE PHASE CONTROL SHOULD BE TURNED CLOCKWISE, AND FOR A NEGATIVE PULSE, COUNTERCLOCKWISE TO STOP THE KLYSTRON FROM OSCILLATING.**

- (3) Adjust the PHASE control so that the test set is not oscillating (see caution above);
- (4) Switch to EXT MOD and, starting the MOD AMP control full counterclockwise, turn it until the klystron is oscillating at the desired frequency;
- (5) The output RF pulse is now of a power of 1 milliwatt peak.

**22. FORMULA 1-TRANSMITTER AVERAGE POWER, P<sub>AV</sub>**

$$P_{av (dbm)} = T_{(dbm)} + B_{(db)} + A_{(db)} + C_{(db)}$$

where:

- P<sub>AV (dbm)</sub> = transmitter average power (in decibels above 1 milliwatt).
- T<sub>(dbm)</sub> = average RF power entering the test set, in dbm (reading of the DBM dial).
- A<sub>(db)</sub> = total attenuation in db of the cable and any external attenuation between the test set and the directional coupler (or pick-up antenna).
- B<sub>(db)</sub> = DBM attenuator correction factor (plus or minus) from RED curves on the calibration chart. (Shown in figure 4-2 as heavy lines extending from + 10 to +30 DBM. )
- C<sub>(db)</sub> = coupling of the directional coupler in db. (Or loss between the radar antenna and the pick-up antenna.)

**23. FORMULA 2-RECEIVER PERFORMANCE, P<sub>m</sub>.**

$$P_{m(dbm)} = M_{(dbm)} + B_{(db)} = A_{(db)} - C_{(db)}$$

where:

- P<sub>m(dbm)</sub> = receiver performance figure in db below 1 milliwatt (-dbm). This is the minimum discernible signal power converted to dbm.
- M<sub>(dbm)</sub> = peak power output of the test set in dbm. This is the "total -dbm" scale reading.
- A<sub>(db)</sub> = total attenuation of the cable and any external attenuators between the test set and the directional coupler, in db.
- B<sub>(db)</sub> = DBM attenuator correction factor (plus or minus) from BLACK curves on calibration chart.
- C<sub>(db)</sub> = coupling of the directional coupler in db. (Or loss between the radar antenna and the pick-up antenna.)

Example:

$$\begin{aligned} M_{(dbm)} &= -60 \\ A_{(db)} &= 3 \\ B_{(db)} &= -1 \\ C_{(db)} &= 20 \\ P_{m(dbm)} &= (-60) + (-1) - (3) - (20) \\ &= -60 - 1 - 3 - 20 = -84 \text{ dbm} \end{aligned}$$

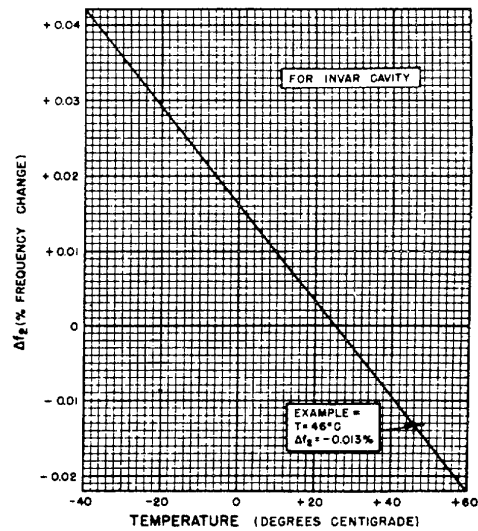

Figure 4-17. Frequency Meter Corrections for Dimensional Changes Due to Temperature

**24. COMPUTING THE TRANSMITTER PERFORMANCE FIGURE.**

Convert the transmitter average power figure, P<sub>av</sub> (See Test 1, par. 6.) to the transmitter performance figure as follows:

$$P_{pk(dbm)} = P_{av(dbm)} + N_{(db)}$$

Where:

**OPERATION**

$P_{pk(dbm)}$  = transmitter performance figure in db above 1 milliwatt (+dbm) (transmitter peak power converted to dbm).

$P_{av(dbm)}$  = transmitter average power in db above 1 milliwatt (+dbm).

$N_{(db)}$  = number of db to be added to the average power in dbm to convert it to peak power in dbm. (See figure 4-19.)

Example:

$P_{av}$  (dbm) = 41.5  
 Pulse Length = 1 u sec  
 Pulse repetition frequency = 650/sec  
 From figure 4-19,  $N_{(db)}$  = 31.8 db  
 $P_{pk(dbm)}$  = 41.5 dbm + 31.8 db  
 = +73.3 dbm

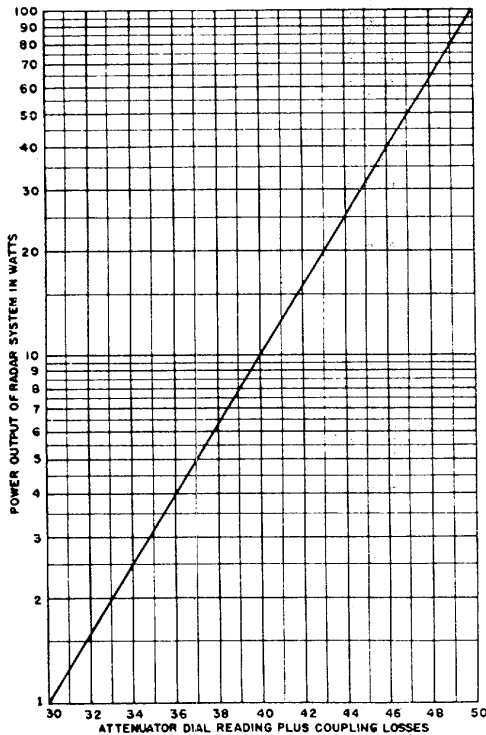

Figure 4-18. DBM to Watts Conversion Chart

**25. COMPUTING IRATED TRANSMITTER AVERAGE POWER IN DBM.**

a. If the rated transmitter average power is known in watts or kilowatts, it can be converted to dbm by use of the chart, figure 4-18. If the rated peak power is the known value, proceed as follows:

(1) Use figure 4-18 to convert rated transmitter peak power from watts or kilowatts to dbm to get the rated transmitter performance figure  $P_{pk(dbm)}$ .

(2) The following formula is used to convert the rated transmitter performance figure to rated average power:

$$P_{av(dbm)} = P_{pk(dbm)} - N_{(db)}$$

Example:

Rated  $P_{pk}$  = 40kw

From figure 4-18,  $P_{pk(dbm)}$  = +76.0 dbm (by extrapolation)

For pulse length of 1 u sec,

Pulse repetition frequency of 650 pulses/sec.

$N_{(db)}$  = 31.8 db (from figure 4-19)

Rated  $P_{av(dbm)}$  = +76 dbm - 31.8 db  
 = +44.2 dbm.

**26. COMPUTING THE RADAR OVERALL PERFORMANCE FIGURES.**

a. The performance figure,  $S$ , is a measure of the ability of a radar to detect small or distant targets. The effect of external factors such as atmospheric conditions, geometry of the target, and ground and water reflections, is not included.

b.  $S_{(db)} = P_{pk(dbm)} - P_{m(dbm)}$

Example:

$P_{pk(dbm)}$  = +73 dbm  
 $P_{m,(dbm)}$  = -93 dbm  
 $S_{(db)}$  = +73 dbm - (-93 dbm)  
 = 166 db

**Note**

**WHEN BEACON OPERATION IS BEING TESTED, THE OVERALL PERFORMANCE FIGURE,  $S$ , DOES NOT APPLY AND THE INDIVIDUAL PERFORMANCE FIGURES FOR TRANSMITTER AND RECEIVER ARE USED.**

c. Compare the radar performance figure  $S_{(db)}$  with the expected performance figure. The expected figure can be obtained from the expected values of  $P_{pk(dbm)}$  and  $P_{m(dbm)}$  or the value obtained when the radar is known to be operating correctly.

Example:

If the expected radar performance figure  $S_{(db)}$  equals 171 db, and the measured radar performance figure  $S_{(db)}$  equals 166 db, the radar performance is down 5 db.

**27. CHANGE IN OVERALL PERFORMANCE.**

For routine measurements and to save time, change in overall performance can be found by adding the differences between the rated and actual values for transmitter average power and receiver performance figure.

THEN MEASURING BEACON PERFORMANCE, IF  $P_{pk(dbm)}$  OR  $P_{av(dbm)}$  IS DOWN, OR INSTANCE, BY 2 DB, AND  $P_{m(dbm)}$  IS DOWN 1.5 DB, THE RANGE AT WHICH THE RADAR COULD TRIGGER A BEACON IS DOWN TO 79% OF NORMAL AND THE RANGE AT WHICH THE RADAR

Section 4  
Paragraph 27

COULD RECEIVE A BEACON SIGNAL IS DOWN TO 84% OF NORMAL.

Note  
REFER TO THE INSTRUCTION BOOK THE EQUIPMENT UNDER TEST OTHER TESTS AND MEASUREMENTS.

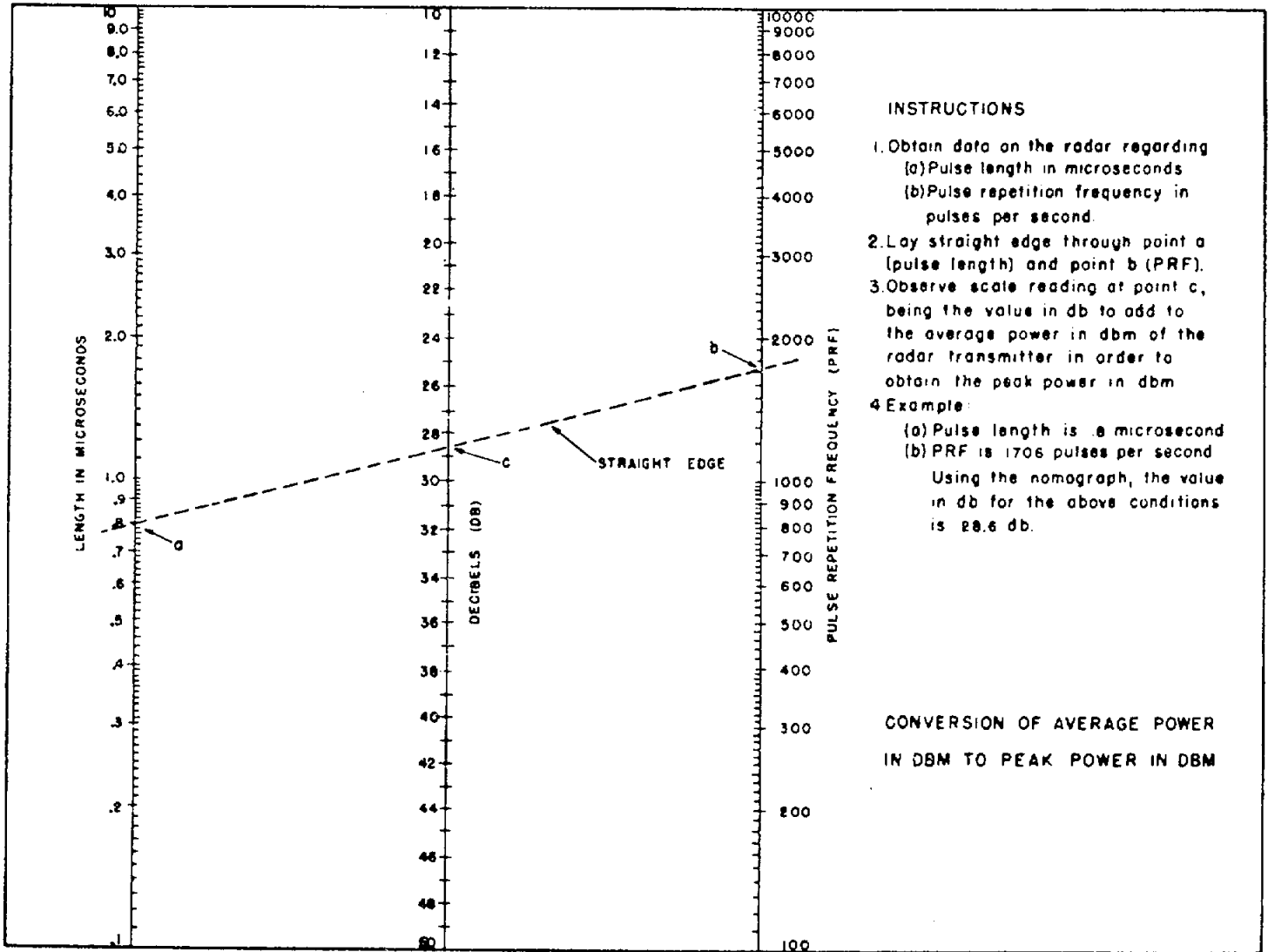

Figure 4-19. Average-to-Peak Power Conversion Chart

**THIS PAGE MISSING FROM ORIGINAL DOCUMENT**

**PAGE #  
5-0**

## SECTION 5

## MAINTENANCE

**1. OPERATOR'S MAINTENANCE.**

a. Because of the highly complex nature of Test Set TS-147D/UP there are no Operator's Maintenance procedures as such. All maintenance procedure performed as Preventive Maintenance or Corrective Maintenance, and must be performed by qualified technicians only.

b. As a rule, the operator of this test set will be a qualified technician.

**2. PREVENTIVE MAINTENANCE.****Note**

**THE ATTENTION OF THE MAINTENANCE PERSONNEL IS INVITED TO THE REQUIREMENTS OF CHAPTER 67 OF THE BUREAU OF SHIPS MANUAL.**

**a. GENERAL.**

(1) Maintenance personnel must at all times avoid disturbing the position or adjustment of any assembly. If the calibration of any part is inadvertently changed, the only practical procedure is to replace the entire assembly with another calibrated unit as covered under corrective maintenance.

(2) Keep the case and panel clean. Avoid solvents or acids that might have a bad effect upon the finish, insulation, fungus protection, etc.

(3) The eight foot RF cord CG-92A/U(8'), which has its attenuation marked on a metal tag, should be recalibrated (See par. 9.) at frequent intervals because of the unstable components in the type of coaxial cable of which this cord is constructed. An attenuation check is particularly important if the cord has been dropped, kinked, bent at sharp angles, handled roughly, or subjected to sudden and extreme changes in temperature.

**b. SEMIANNUAL INSPECTION.**

(1) With the front panel of the test set facing upward, unfasten the four thumb screws and lift the chassis from the carrying case, taking care not to bump any of the components against the cabinet flanges.

(2) Using an approved blower or other source of air for the purpose, blow the dust out of the equipment, observing the caution in par. 2a(1).

(3) After about 500 hours or at semiannual periods, all tubes in the unit should be tested. Any tube showing subnormal characteristics should be replaced.

c. LUBRICATION.-Lubrication is not required for any part of this equipment.

**3. CORRECTIVE MAINTENANCE, GENERAL.****WARNING**

**THE HIGH VOLTAGES USED IN THIS EQUIPMENT ARE DANGEROUS TO LIFE. OBSERVE ALL SAFETY REGULATIONS.**

a. Test Set TS-147D/UP is a calibrated measuring instrument, precisely manufactured. Consequently, field maintenance is necessarily limited to trouble shooting in the electrical circuits and the replacement of complete assemblies in the RF plumbing section, and these only by competent technicians. Maintenance personnel must at all times avoid disturbing the fixed adjustments of any of the calibrated assemblies, otherwise shipment to a repair base may be necessary. If the calibration of any part is inadvertently changed, the only practical procedure is to replace the entire assembly with another calibrated unit.

b. General inspection and testing of the test set can be done by following the method outlined in Section 3, par. 2 and 4. The performance characteristics for normal operation are given in Section 1, par. 5, under Reference data.

**WARNING**

**ALWAYS REMOVE THE POWER CORD PLUG FROM THE AC SUPPLY SOURCE BEFORE ANY WORK IS COMMENCED OR THE CHASSIS IS REMOVED FROM THE CARRYING CASE. VOLTAGE IS PRESENT EVEN WHEN THE SWITCH IS OFF.**

c. When it is necessary to operate the test set out of its carrying case for trouble shooting or making tests, the usual precautions should be observed. When the ON-OFF switch (S101) is in the OFF position, AC line voltage is being supplied to the stand-by heaters. When the set is operating, there is 1700 volts AC across the high voltage winding of the power transformer as well as at the socket of the high voltage rectifier V101. There are points in the power supply section where the voltage is over 700 volts DC and places throughout the set where it is 300 volts. Never probe in the interior of the unit with anything metallic such as a screwdriver, etc. Obtain a rod of non-conducting material such as bakelite for the purpose.

**4. REMOVAL OF UNITS.****a. GENERAL.**

(1) Test Set TS-147D/UP has wave guide plumbing components, mounted on the rear of the panel, a power supply and voltage regulator strip, and a video

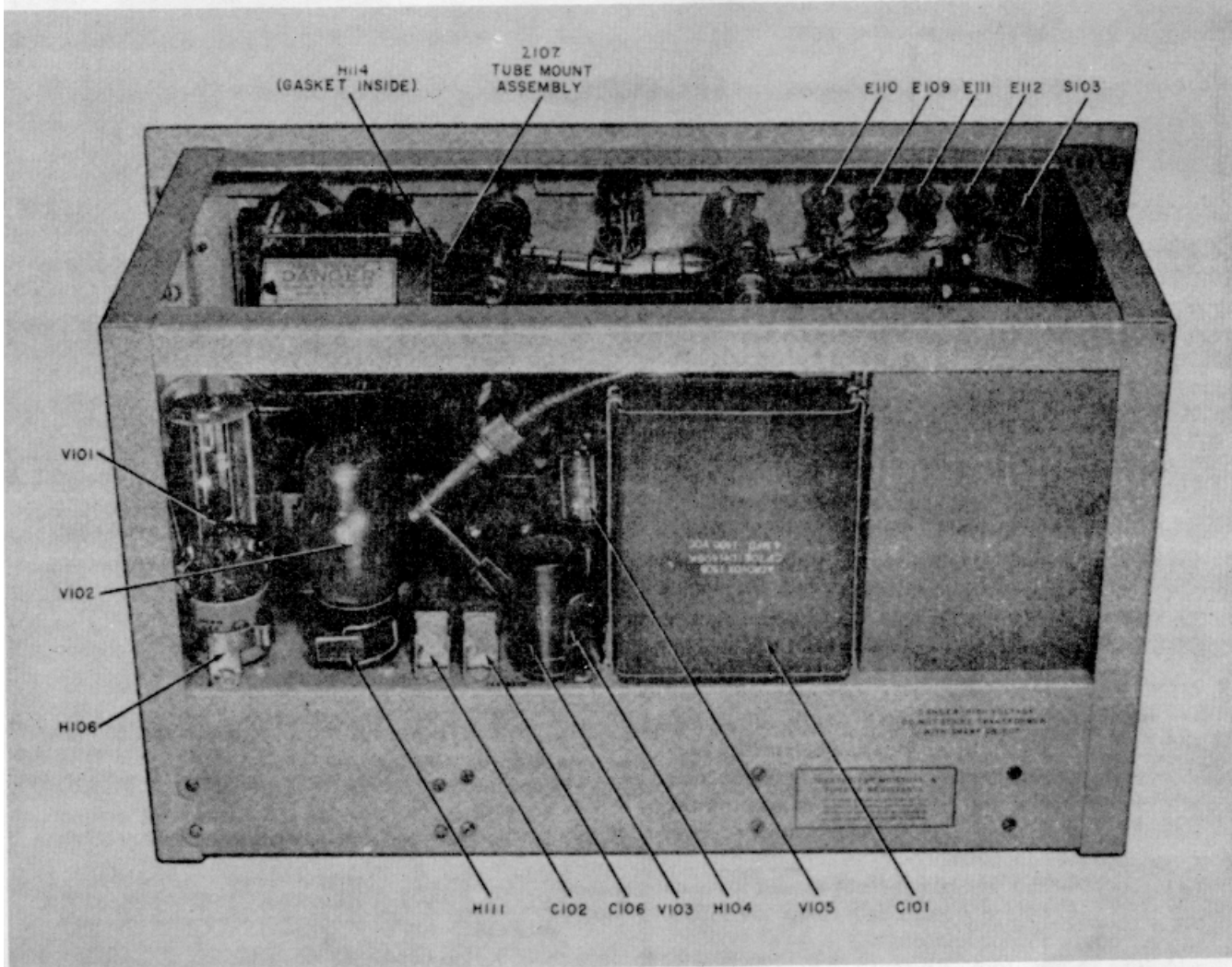

Figure 5-2. Test Set Chassis Rear View

amplifier subassembly (U101) which contains the trigger amplifier and blocking oscillator.

(2) It is removed [from the carrying case by laying the instrument on its back with the front panel facing upward, loosening the four thumb screws on the panel of the test set, and lifting the chassis from the case with the two handles provided, taking care not to bump the components against the cabinet flanges. With the test set out of the case, parts of the video amplifier (U101) are accessible through an opening in the right end of the test set chassis.

**5. RF PLUMBING.**

**a. GENERAL.**

(1) The illustrations in Section 2 (See figures 2-2 to 2-16 inclusive.) show the following nine RF plumbing components of the test set:

(a) Tube mount assembly;

(b) Frequency meter assembly;

(c) Thermistor mount;

(d) DBM calibrated attenuator;

(e) "E" bend, wave guide elbow;

(f) "H" bend, wave guide elbow;

(g) "E" bend, wave guide elbow;

(h) Dual or step attenuator;

(i) RF output and crystal detector section.

(2) It will almost never be necessary to remove and replace parts of the RF plumbing for any reason, unless the test set has been subjected to rough handling, such as being dropped, or the mechanical adjustments have been disturbed by jarring or tampering.

(3) The following assemblies (See figures 5-5 and 5-6.) can be removed and replaced with new parts without affecting the calibration curve supplied with each test set:

(a) Tube mount assembly;

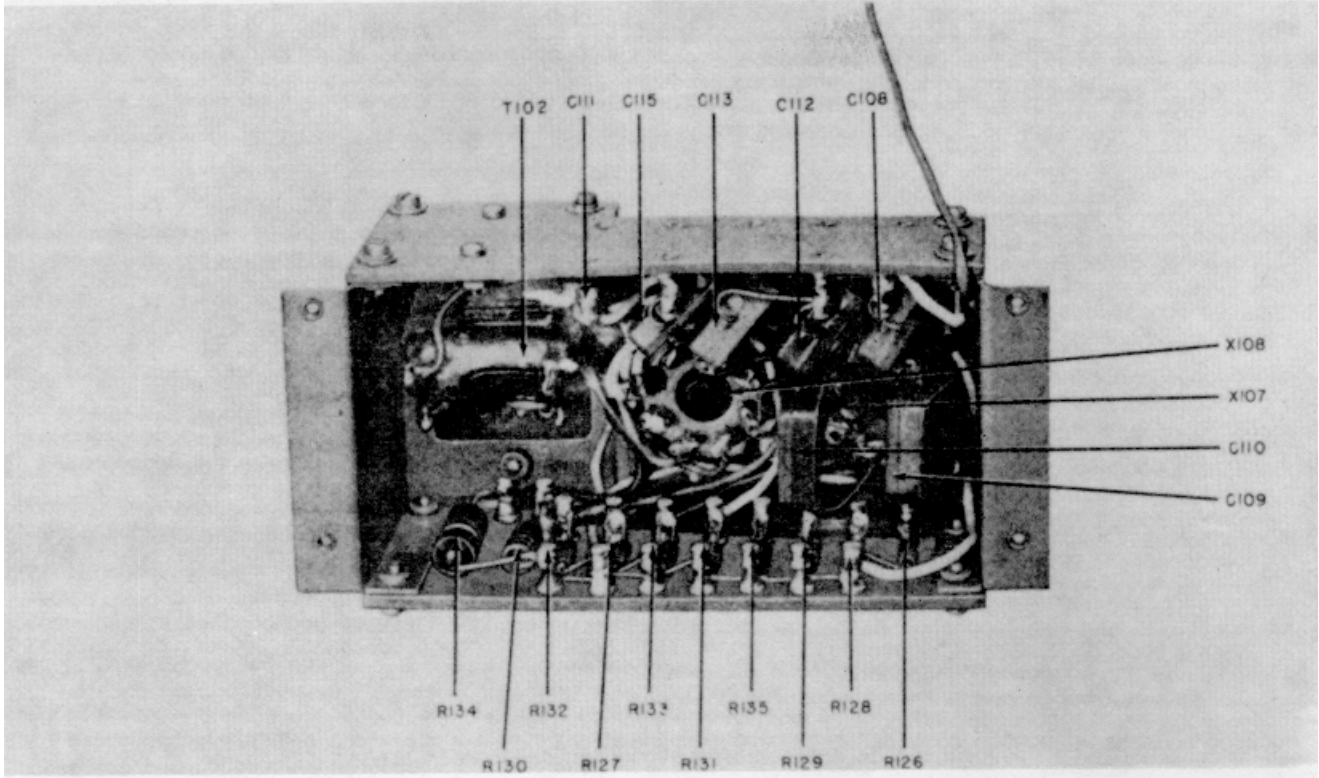

Figure 5-3. Video Amplifier Sub-Assembly, Bottom View

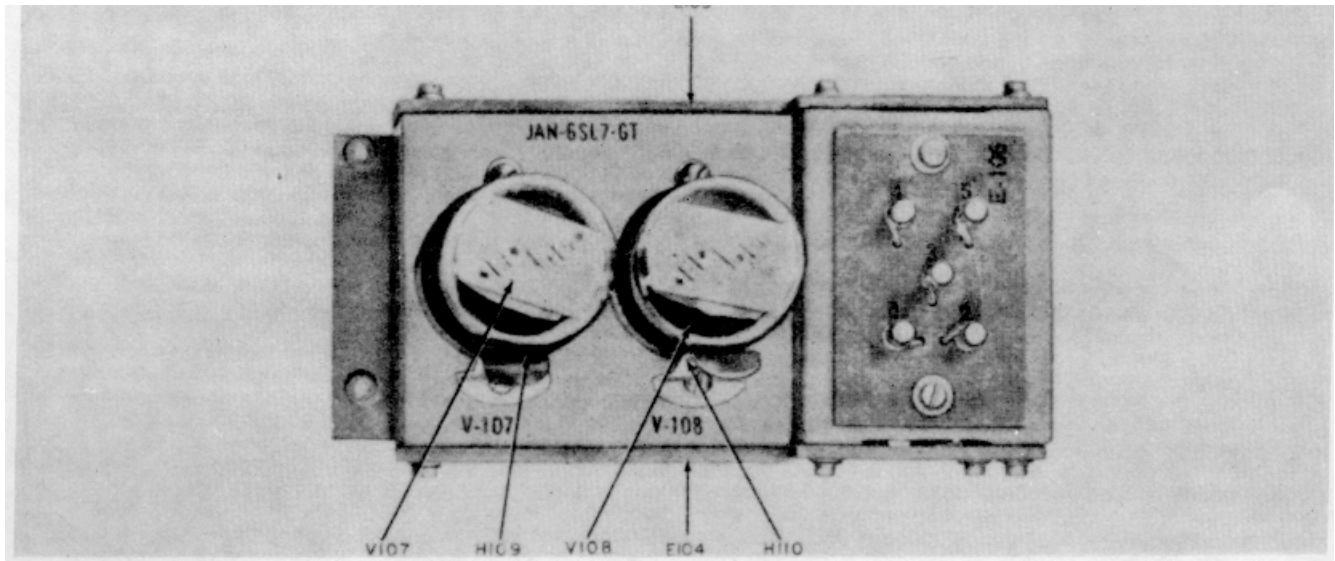

Figure 5-4. Video Amplifier Sub-Assembly, Top View



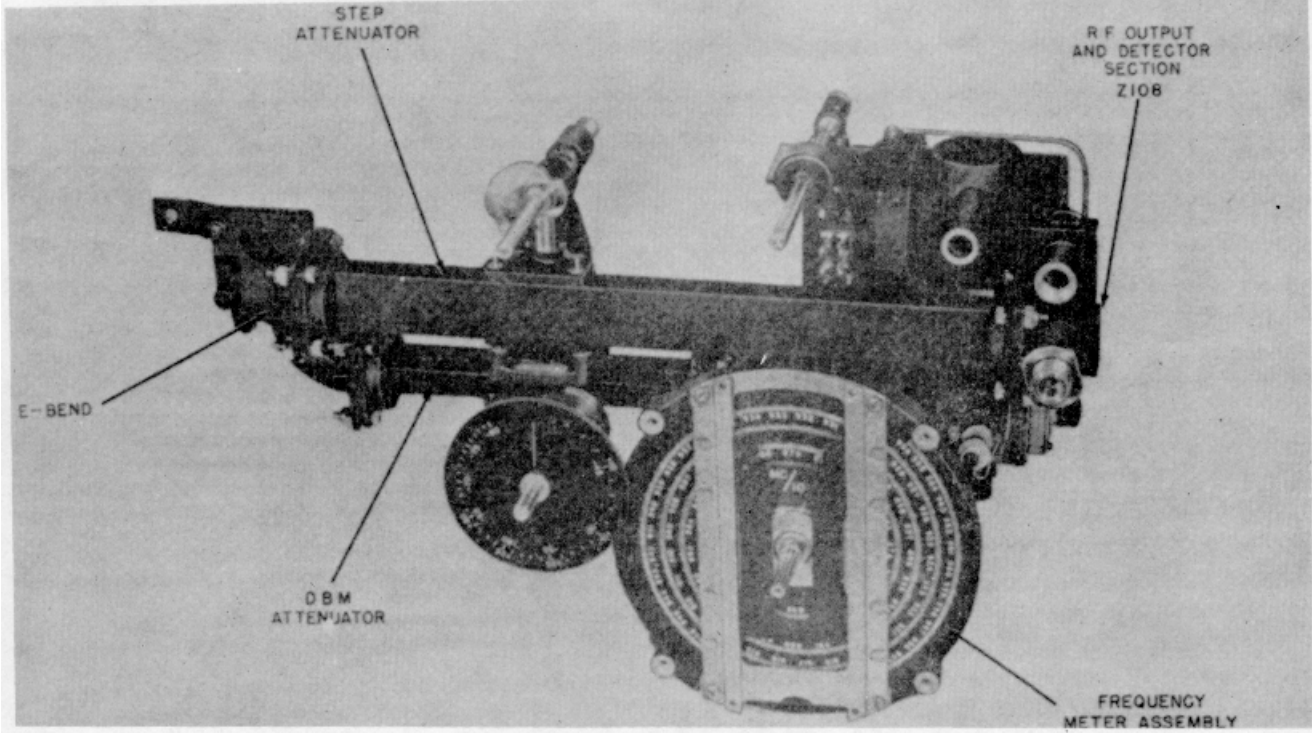

Figure 5-5. Assembled Wave Guide, Front View

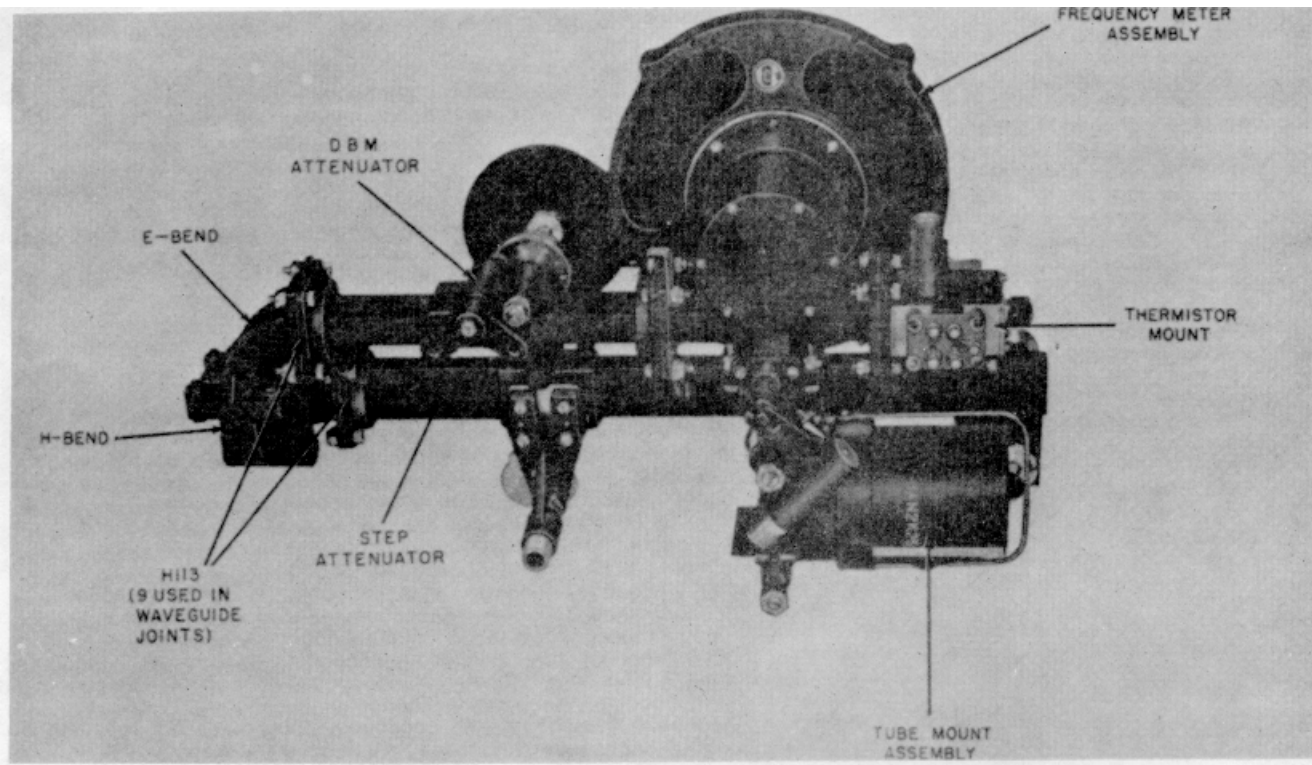

Figure 5-6. Assembled Wave Guide, Rear View

## MAINTENANCE

## Section 5

### Paragraph 5 a (3) (b)

#### (2) RF OUTPUT AND DETECTOR SECTION.

- (b) Frequency meter assembly;
- (c) "E" bend, wave guide elbow;
- (d) "H" bend, wave guide elbow;
- (e) "E" bend, wave guide elbow;
- (f) RF output and detector section.

(4) Replacement of the following assemblies will affect the calibration of the instrument:

- (a) Thermistor mount;
- (b) DBM calibrated attenuator;
- (c) Dual or step attenuator.

(5) If one or more of the assemblies listed in par. (4) above are removed and replaced with others, the calibration curve supplied with the instrument will be affected somewhat. If the three items are acquired as a calibrated unit, they should be accompanied by a calibration chart, in which case, the three assemblies and the curve should be substituted for the originals.

(6) Whenever any wave guide sections are removed, always use new gaskets between the flange joints when reassembling. Be sure to mount the gaskets in the right direction, otherwise a large part of the opening will be blocked, which will cause very high standing wave voltage ratio in the wave guide.

(7) The three wave guide elbows, marked EBEND, H-BEND, and E-BEND (Z104) in figure 2-2, need never be separated, and should be removed as a unit where they join the dual or step attenuator on top and the DBM calibrated attenuator on the bottom.

(8) If the RF cutoff (See figure 2-2.) does not entirely open when the TEST knob is turned to the Red-Dot or RECV positions, the trouble will usually be caused by the flexible shaft slipping in the end fittings or a binding flexible shaft between the TEST switch and the RF cutoff. Loosen the knurled locking nuts at the cable ends, and shift the position of the flexible shaft slightly, then retighten the locking nuts while moving the TEST knob between the TRAN and Red Dot positions to be sure the shaft is being locked in a non-binding position. Watch out for binding in the RECV position.

(9) Most of the RF plumbing assemblies can be removed and replaced without too much trouble. However, it will be found necessary to unfasten the front panel from the chassis when removing the following:

- (a) Frequency meter.
- (b) DBM calibrated attenuator.
- (c) RF output and detector section.

#### b. REMOVING AND REPLACING ASSEMBLIES.

##### (1) FRONT PANEL.

(a) Remove the 6/32 machine screw on the power supply shelf between V105 and V106 by unloosening the hex nut from the bottom. This screw ties a bracket from the wave guide to the power supply shelf.

(b) Remove the machine screw from the cable clamp next to the 115v AC receptacle, at the rear of the front panel.

(c) Remove the four black binding head machine screws which fasten the front panel to the chassis frame. These will be seen near the ends of the panel in front.

(d) The front panel now can be moved away slightly from the chassis frame.

(e) When restoring the panel, be careful not to kink or mash the wires between the panel and chassis frame.

(a) Unfasten the front panel as in par. 5b(1).

(b) Remove the SIGNAL FREQ knob and shaft, the cover of the oscillator tube mount, and the klystron tube (V104). (See par. 7b.) (c) Use a 13/16 inch open end wrench to loosen and unscrew the RF connector on the front panel and remove the rubber washer.

(d) Unscrew the CRYSTAL holder from the front panel and remove the rubber washer.

(e) Unsolder the wires from the crystal contact, at the rear of the output and detector section, and the shield lug from under the screw on the back of the CRYSTAL holder.

(f) Remove the four nuts and bolts from the flange connecting the dual or step attenuator with the RF output and detector section. Then the RF output and detector section assembly can be taken out.

(g) When replacing this assembly with another, be sure to use a new gasket. Mount the gasket in the proper direction at the flange joints of the wave guide.

##### (3) DBM CALIBRATED ATTENUATOR.

(a) Unfasten the front panel as in par. 5b(1).

(b) Remove the DBM knob at the front of the panel.

(c) Remove the eight nuts and bolts from the flanges of the wave guide.

(d) Remove the voltage regulators (V105 and V106).

(e) The attenuator assembly can now be removed by moving the panel out somewhat from the chassis and sliding the attenuator toward the rear and upward.

(f) When replacing the attenuator assembly, be sure that the red hairline of the DBM window is aligned with the white index line of the dial which should appear under the hairline when the attenuator shaft is turned to the extreme clockwise position (minimum attenuation). If it does not, loosen the two screws holding the DBM window on the rear of the panel, and move the window until exact alignment is obtained. This operation will permit the new assembly to be installed without laboratory calibration.

(g) When another assembly is received as a spare part, the calibrated dial may not be attached to the attenuator shaft. In that case, be sure that the serial number on the back of the new dial corresponds to the marking on the attenuator wave guide, as each one is specifically engraved to conform with the individual attenuator.

(h) The new dial can be slipped on the

shaft and the new assembly returned to the position of the former one in the test set.

(i) After all parts have been restored and tightened, the dial should be fastened to the shaft, by the two Allen socket head set screws, in the space between the panel window and the frequency meter casting. The dial must not rub after the attenuator shaft has been turned to the extreme clockwise position (minimum attenuation). The set screws should be tightened when the white index line on the minimum attenuation end of the dial is exactly vertical and aligned with the red hairline on the window. If, at that time, it is found that the red hairline is not directly over the white one, loosen the two small screws holding the DBM window on the rear panel slightly and move it until it is in alignment. The DBM attenuator with its associated dial will now read as originally calibrated.

(4) FREQUENCY METER.

(a) Remove the TEST, POWER SET, DBM, and FREQUENCY knobs.

(b) Remove the SIGNAL FREQ knob and shaft. (See par. 7b (3).)

(c) Unscrew and remove the CRYSTAL holder and rubber washer.

(d) Unscrew and remove the RF connector and rubber washer, using a 13/16 inch open end wrench.

(e) Remove the frequency meter window frame.

(f) Remove all tubes from the power supply shelf.

(g) Loosen the knurled lock nuts and remove the flexible shaft. Tie the RF cutoff in a closed position (plunger in) with a rubber band.

(h) Remove the wave guide flange screws from the tube mount and lay back the assembly, being careful not to cut or break the wires.

(i) Remove the thermistor mount taking the same care with the wires.

(j) Remove the bracket to the power supply shelf and the flange screws holding the DBM attenuator to the frequency meter wave guide.

(k) Remove the machine screw, between the FUSE holder and the thumb screw on the front panel which holds the wave guide bracket.

(l) Unfasten the front panel. (See par. 5b (1).) (m) Loosen only, the four frequency meter mounting screws on the front panel.

(n) Pull the panel out at the bottom and away from chassis. It will remain fairly close to the chassis frame at the top.

(o) Remove the four mounting screws from the front panel while holding the frequency meter assembly. When loose, slide the frequency meter assembly down and remove it from the bottom of chassis.

(p) Replace the frequency meter in the reverse order taking care not to break, kink, cut, or mash the wires. Use new gaskets between wave guide flanges and use care to install them in the right direction.

(q) Set the dial stop at the end of the frequency meter range and lock. Check to see if the dial stop sets the frequency properly.

6. OPERATING MAINTENANCE REPAIR PARTS.

a. GENERAL.-Certain parts of the set are considered to be operating maintenance repair parts. These parts may be replaced by maintenance personnel.

b. GASKETS.-Gaskets for the wave guide gasket flange joints are to be replaced if they are found to be corroded or when re-assembling the plumbing. A new gasket should always be mounted so that it does not block the wave guide.

c. THERMISTOR MOUNT ASSEMBLY.

(See figure 2-10.)

(1) A new thermistor mount is installed as follows:

TABLE 5-1. RATED TUBE CHARACTERISTICS

TUBE TYPE	FILA- MENT VOLT- AGE (V)	FILA- MENT CUR- RENT (A)	PLATE VOLT- AGE (V)	GRID BIAS (V)	SCREEN VOLTS (V)	PLATE CUR- RENT (MA)	SCREEN CUR- RENT (MA)	AC PLATE RESIST- ANCE (OHMS)	VOLT- AGE AMPLI- FICA- TION (MU)	TRANSCON- DUCTANCE (UMHOS)		EMISSION	
										NORM	MIN	15 (MA)	TEST VOLT (V)
OC3/VR105	—	—	Voltage Regulator starting at 135v. Operating: volts 105, current 5 to 40 ma.										
2K25	6.3	0.44	Resonator 300 v Reflector -130 v to -185 v Power 33 mw 250 v (4th Mode) -84 v to -122 v Output 25 mw										
5R4GY	5.0	2.0	900 volts RMS/plate, 150 ma dc output, condenser input to filter. 950 volts RMS/plate, 175 ma dc output, choke input to filter.										
6SH7	6.3	0.3	100 250	- 1.0 - 1.0	100 150	5.3 10.8	2.1 4.1	350,000 900,000		4000 4900			
6SL7GT EACH SECT.	6.3	0.3	250	- 2.0		2.3		44,000	70	1600			
6Y6G	6.3	1.25	135 200	-13.5 -14.0	135 135	58.0 61.0	3.5 2.2	9,300 18,300		7000 7100			

Paragraph 6 c (1) (a)

(a) Take off the four nuts from the screws that fasten the thermistor mount flange to the frequency meter flange, using an 11/32 inch open end wrench. Unclamp and remove V101 and V102 to facilitate loosening the nuts. The thermistor mount can now be released from the plumbing and pulled away from the assembly.

(b) At the thermistor mount, unsolder the seven wires from the terminals numbered 1, 2, 3, 4, and 5. The remaining wires need not be removed as they will be found intact on the replacement mount.

(c) Solder the seven wires to the replacement mount in the same positions as on the original mount. (The Wiring Diagram, figure 5-12, shows the color coding.)

(d) When attaching the new mount to the frequency meter flange, use a new gasket and make sure that it is properly oriented with respect to the length and width of the wave guide. Be sure to replace the new mount in the same position as the old one was in before disassembly.

d. FUSES.-Two spare fuses are supplied to replace the two fuses in the primary circuit of the power transformer. These spares are contained in the holders marked SPARES on the front panel.

e. CRYSTALS.-To replace a crystal, unscrew the knurled cap marked CRYSTAL on the panel, put a new crystal into the holder in the cap, and replace the cap.

f. DIAL LAMPS.-To replace a 3.0 volt lamp used to illuminate the FREQUENCY and DBM dials on the control panel, unscrew the defective lamp from the front panel and screw in a new lamp. These lamps are very fragile. Consequently, care is required during replacement.

7. TUBE INFORMATION.

(See tables 5-1, 5-2, and 5-3.)

a. GENERAL.-All the tubes with the exception of the klystron oscillator (V104) are easily accessible and

TABLE 5-2. DC RESISTANCE CHART

NOTE: ALL VALUES TO GROUND

SYMBOL DESIGNATION	TYPE	PIN NUMBER							
		1	2	3	4	5	6	7	8
V101	5R4GY	—	150K	—	11K	—	11K	—	150K
V102	6Y6G	—	∞	150K	150K	2.5M	—	∞	30K
V103	6SH7	—	0.1	—	130K	0	90K	0	2.5M
V104	2K25	30K	0.1	—	—	—	—	0	0
V105	0C3/VR105	—	*5500	—	—	0	—	—	—
V106	0C3/VR105	—	10K	—	—	*5500	—	—	—
V107	6SL7GT	4700	62K	1K	100K	62K	0	0.1	0
V108	6SL7GT	100K	62K	1K	11	30K	6800	0.1	0

\* Varies with SET ZERO-COARSE and -FINE controls.

K = 1,000 ohms.

M = 1,000,000 ohms.

can be removed and replaced without detaching other parts.

b. KLYSTRON OSCILLATOR TUBE (V104). (See figures 2-2, 2-6, 2-7, 5-6, and 5-8.)

WARNING

**BE SURE THAT THE 115V AC POWER IS DISCONNECTED FROM THE TEST SET BEFORE ATTEMPTING TO REMOVE V104, AS THE METAL SHELL ENVELOPE IS AT + 300 VOLTS DC TO GROUND AND ANYWHERE FROM 360 TO 510 VOLTS (DEPENDING UPON CONTROL SETTINGS) BETWEEN THE TUBE SHELL AND THE REFLECTOR CAP CONNECTION ON THE TOP OF THE TUBE.**

(1) The tuning range of the test set is covered by about 3-1/4 turns of the SIGNAL FREQ knob coupled to the adjusting nut on the klystron oscillator (V104).

This nut lengthens or shortens the distance between the ends of the adjustable struts which in turn varies the volume of the resonator chamber of the 2K25 klystron tube. When the adjustment nut is turned fully clockwise and the tube is at the low frequency end of the tuning range, the expanded bows of the tube are at their shortest dimension, end to end. Continuing to turn the nut will cause the tension to increase to a point where the nut will bind. Any attempt to turn the nut further will damage the tube. When a stop is reached at the counterclockwise or high frequency end, the split adjustable strut sections are together, and further turning of the adjusting nut will strip the threads of the screw on the tube.

(2) During normal operation, the 2K25 klystron tube will get very hot, beyond the point which the human hand can tolerate, and will remain so for some time after the test set has been turned off. It is

## MAINTENANCE

therefore advised that the test set be turned off and the shielding cover removed until such time as the tube can be comfortably handled.

(3) While steadying the SIGNAL FREQ knob with the right hand, disengage the snap-slide fastener behind the panel with the left. It is then possible to remove the knob and shaft as a complete unit.

(4) Release the snap-wire and take off the cover of the tube mount sub-assembly. Disconnect the connection to the cap, then push the clamping spring away from the tube base and carefully pull the tube from the socket.

(5) When putting a new tube into the socket,

## 5 Section Paragraph 7 b (2)

make sure that the output probe of the tube fits into the enlarged hole (pin 4) in the octal socket. Be careful not to bend the probe in the process, otherwise the tube will be rendered useless. Replace the tube cap connection and replace the tube clamp to the bare. Pi-t the cover back on the tube mount sub-assembly.

(6) Push in the SIGNAL FREQ knob and shaft with a gentle twisting motion engaging the tuning nut on the oscillator tube. Secure the shaft of this tuning control by means of the snap-slide fastener with the left hand while steadying the knob with the other.

TABLE 5-3. DC VOLTAGE CHART

**NOTE: ALL VALTUES TO GROUND EXCEPT WIHERE NOTED  
(USE VOLTMETER OF 20,000 OHMS, VOLT SENSITIVITY)**

SYMBOL DESIGNATION	TYPE	PIN NUMBER							
		1	2	3	4	5	6	7	8
V101	5R4GY	—	600	—	860AC	—	860AC	—	600
V102	6Y6G	—	*	590	590	230	—	*	300
V103	6SH7	—	6.3AC	—	-5	0	160	0	230
V104	2K25	300	6.3AC	—	—	—	—	0	0
V105	0C3/VR105	—	-105	—	—	0	—	—	—
V106	0C3/VR105	—	-210	—	—	-210	—	—	—
V107	6SL7GT	0	235	2.2	-1	185	0	6.3AC	0
V108	6SL7GT	0	235	2.2	0	300	18	6.3AC	0

\* 6.3 volts AC between pins marked with an asterisk.  
Line voltage 115v AC.

## 8. ADJUSTMENTS.

a. GENERAL.-The SET ZERO--COARSE potentiometer (R124) is the only adjustment in the test set that can be made by maintenance personnel without danger of changing the calibration or linearity of the instrument.

b. SET ZERO COARSE POTENTIOMETER (R124).

(1) When it is found that the SET ZERO-FINE control will not permit the meter needle to read SET ZERO, as when first attempting to operate the test set under frigid conditions, it may be found necessary to use the SET ZERO--COARSE potentiometer. When the instrument has reached a normal operating temperature, it may again be necessary to readjust the SET ZERO-COARSE potentiometer to somewhere near its original setting.

(a) With the test set out of its carrying case, apply 115 volts AC and allow about two minutes to warm up.

(b) Put the TEST knob on TRAN.

(c) Put the SET ZERO-FINE control in the middle of its range (white index mark up).

(d) Use a screw driver to alter the SET ZERO -COARSE potentiometer until the meter reads SET ZERO.

c. SWEEP ADJUST POTENTIOMETER (R142).

(1) The purpose of this control is to produce linearity in the slope of the sawtooth sweep wave for the klystron oscillator (V104). It is shown in figure 5-10 and is mounted underneath the power transformer. It has been preset at the factory while checking the linearity on a synchroscope and secured in that position with brown cement. It will never require adjustment unless inductance L102, capacitor C114 (wiring capacity to ground) or both are changed. Under normal conditions, the tolerances are such that even though the inductance L102 is replaced, no readjustment need be made in the setting of R142. The method follows however if the sawtooth sweep must be adjusted for linearity:

(a) Turn on the test set and, while it is warming up, set up the following:

(b) With the INT FM-EXT MOD switch in the INT FM position, connect an oscilloscope or synchroscope vertical or signal input to the reflector side of C107. (With the test set upside down, C107 is mounted on the last contacts of terminal strip E101 over the power transformer; and the reflector side is closer to the transformer.) Use a suitable positive source to trigger both the test set at the TRIGGER connector (J102) and the horizontal input or start/stop sweep of the oscilloscope (or synchroscope).

(c) Turn the SIGNAL WIDTH control to MIN and the PHASE control to MAX.

(d) After the warm-up period of about two minutes, use a screwdriver to set the SWEEP ADJUST potentiometer (R142) so that the sawtooth wave reaches 100v at 50 u sec. This setting should produce a linear sweep.

**9. CALIBRATION OF ATTENUATION OF CORD CG-92A/U (8').**

a. The eight foot Cord CG-92A/U(8') (W10I) which has its attenuation marked on an attached metal tab, should be recalibrated at frequent intervals, because of the unstable components of the type of coaxial cable of which this cord is constructed. An attenuation check is particularly important if the cord has been dropped, kinked, bent at sharp angles, handled roughly, or subjected to extremes in temperature.

b. Connect any 52 ohm cord between the RF connector of the test set and the radar directional coupler as shown in figure 4-3. Make TEST 1A, Section

4, par. 6, to get the average power,  $P_{av}$ , in dbm entering the test set.

c. Connect the cord to be calibrated in series with the one used in par. 9b above, using a UG-29B/U or UG-30B/U connector and again measure the average RF power,  $P_{av}$  in dbm entering the test set.

d. The difference between the DBM dial readings in the above two tests will give the attenuation of the cord that is being calibrated.

**10. TROUBLES AND REMEDIES, TEST SET TS-147D/UP.**

a. The principal troubles incident to the Test Set TS-147D/UP are listed in table 5-4 together with the appropriate causes and remedies.

TABLE 5-4. TEST SET TS-147D/UP TROUBLES AND REMEDIES

SYMPTOMS	PROBABLE CAUSES	REMEDIES
<p>a. Meter cannot be balanced by SET ZERO-FINE control.</p> <p>b. Meter off scale to right.</p> <p>c. Meter off scale to left.</p> <p>d. Meter off scale to left. (1) VR tubes (V105 and V106) glowing very brightly. (2) F101 or F102 overloaded.</p> <p>e. Meter reads SET POWER (zero current). (1) Bridge circuit inoperative. (2) Control grid of V103 glowing. (3) V102 overheating.</p> <p>f. One dial lamp cut, other still on.</p> <p>g. No test signal output indication on bridge meter.</p> <p>h. Test signal power output cannot be controlled by POWER SET knob.</p> <p>i. No frequency modulation of test signal output.</p> <p>j. Test oscillator signals on oscilloscope appear jittery.</p>	<p>(1) SET ZERO-FINE control (R124) needs adjustment. (2) See symptoms b, c, d, and e,</p> <p>(1) Short circuit across bead in thermistor mount assembly (Z109).</p> <p>(1) Open bead-thermistor in Z109. (2) See symptom d.</p> <p>(1) Any short circuit from -1-300v supply to ground.</p> <p>(1) Any short circuit from -210v supply to ground.</p> <p>(1) Either 1101 or 1102 burned out.</p> <p>(1) Defective oscillator tube (V104). (2) R.F cut-off jammed. (3) Bridge circuit inoperative.</p> <p>(1) Broken glass strip in power-set attenuator of tube mount (Z107).</p> <p>(1) Sweep not being triggered by RF in-put. (a) Transmitter output weak. (b) Defective crystal CR101. (c) Weak amplifier tube. (d) Defective blocking oscillator transformer.</p> <p>(2) Sweep not being triggered by video trigger (IFF). (a) Lack of or weak trigger voltage source. (b) Weak amplifier tube.</p> <p>(3) Test oscillator circuit fault.</p> <p>(1) Ripple present at reflector of Test oscillator tube (V104). (2) Weak triggering of sweep generator. (3) Multiple triggering sweep generator.</p>	<p>(1) Adjust R124.</p> <p>(1) Replace Z109.</p> <p>(1) Replace Z109.</p> <p>(1) Correct short circuit. (a) Check polyiron terminal block in tube mount (Z107) for voltage breakdown.</p> <p>(1) Correct short circuit.</p> <p>(1) Replace burned out lamp.</p> <p>(1) Replace V104. (2) Check cut-off mechanism and flexible shaft. (3) See symptom e. (1) Replace tube mount (Z107).</p> <p>(1) Check amplifier and crystal (CR101). (a) Check transmitter output power. (b) Replace CR101. (c) Replace V107 and V108. (d) Replace T102.</p> <p>(2) Check amplifier. (a) Check trigger source. (b) Replace V108.</p> <p>(3) Check SIGNAL WIDTH potentiometer (R137) and capacitor C107. (1) Check filter of - 210v section of power supply. (2) Check crystal (CR101) and amplifier. (3) Check trigger source. (4) Check R134 and R135. (5) Switch the radar system under test to a new repetition rate.</p>
	<p>5-10</p>	<p>ORIGINAL</p>

TABLE 5-5. WINDING DATA

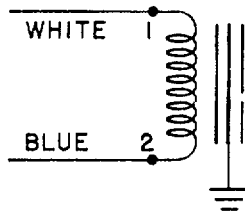
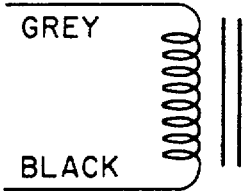
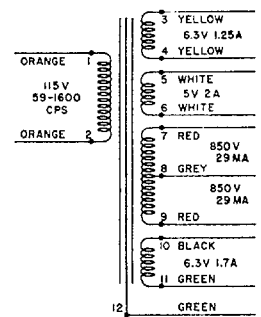
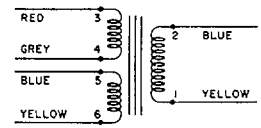
DESIG-NATION SYMBOL	GCC PART NO.	DIAGRAM	WINDING	WIRE SIZE	TURNS	DC RESIST-ANCE IN OHMS	IMPEDANCE RATIO	HIPOT AC VOLTS	REMARKS
L101	P320-B-23 (B-50404)		Single	AWG37	2,208	390	—	2,500	Inductance: 7.5 by +15% -5% with ten volts RMS @ 120 cps and 0.045 am-pere DC thru winding. Finished w/ fosterite process.
L102	P320-B-22 (B-50413)		Single	AWG36HF	3,000	227	—	1,780	Inductance: 5.5 by +20% -10%. Fin-ished w/fos-terite proc-ess.
T101	P320-C-20 (C-50374)		Primary Secondary 1 Secondary 2 Secondary 3 Secondary 4	23HF 22HF 21HF 37F 3x25HF	365 22 18 6010 ct 22	3.57 ±10% 0.230 ±10% 0.155 ±10% 1812 ±15% 0.165 ±10%	— — — — —	1,500 1,500 1,500 2,700 1,500	
T102	P320-B-160 (B-50374)		Primary Secondary 1 Secondary 2	33 33 38	90 90 135	2.6 ±10% 2.8 ±10% 14.5 ±10%	— 1:1 1:045	1,000 1,000 1,000	With 1, 3, and 5 grounded and a positive pulse applied at 2, a positive pulse will come out at 4 and 6.



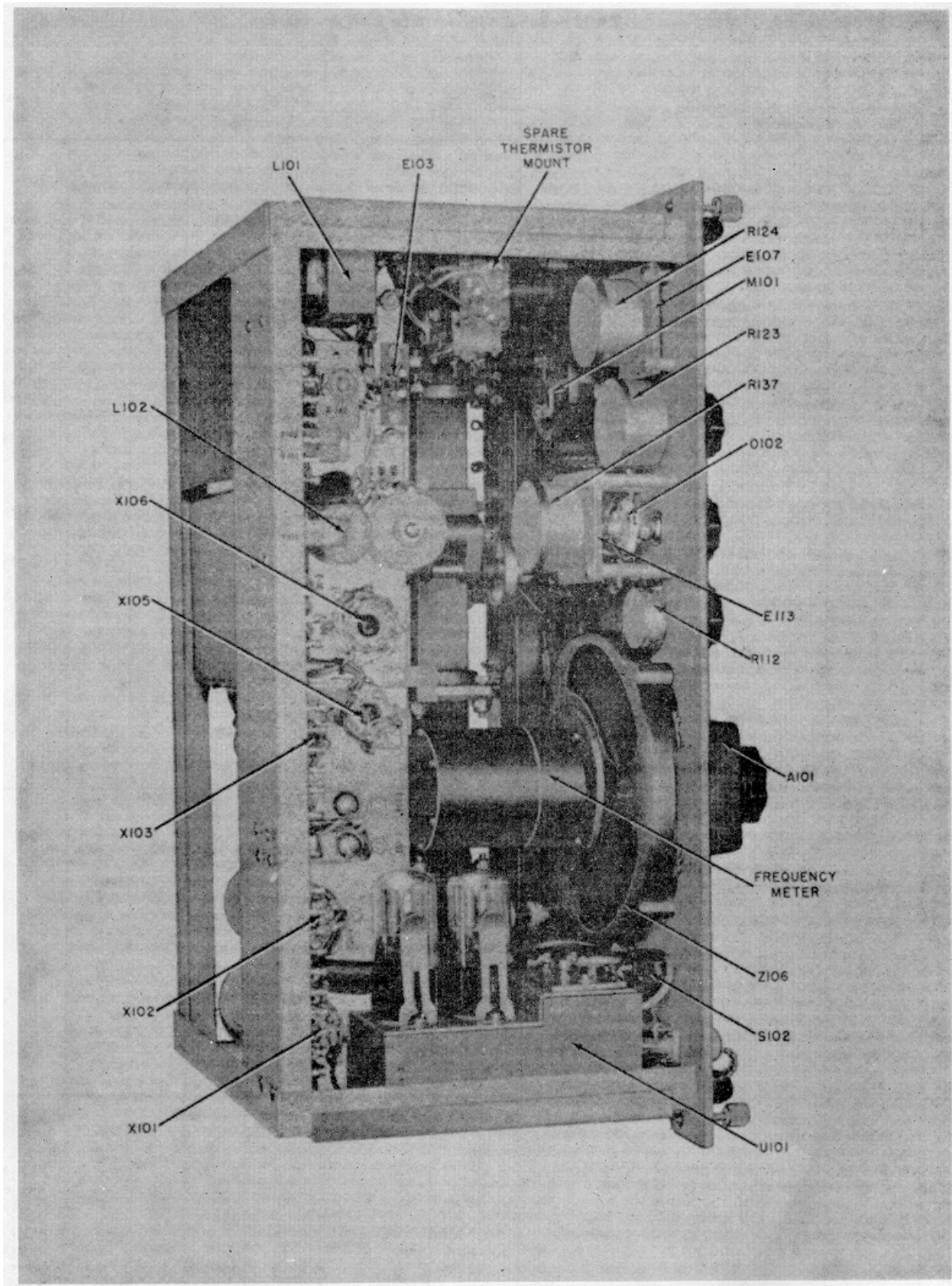

Figure 5-7. Test Set Chassis Bottom-Rear View

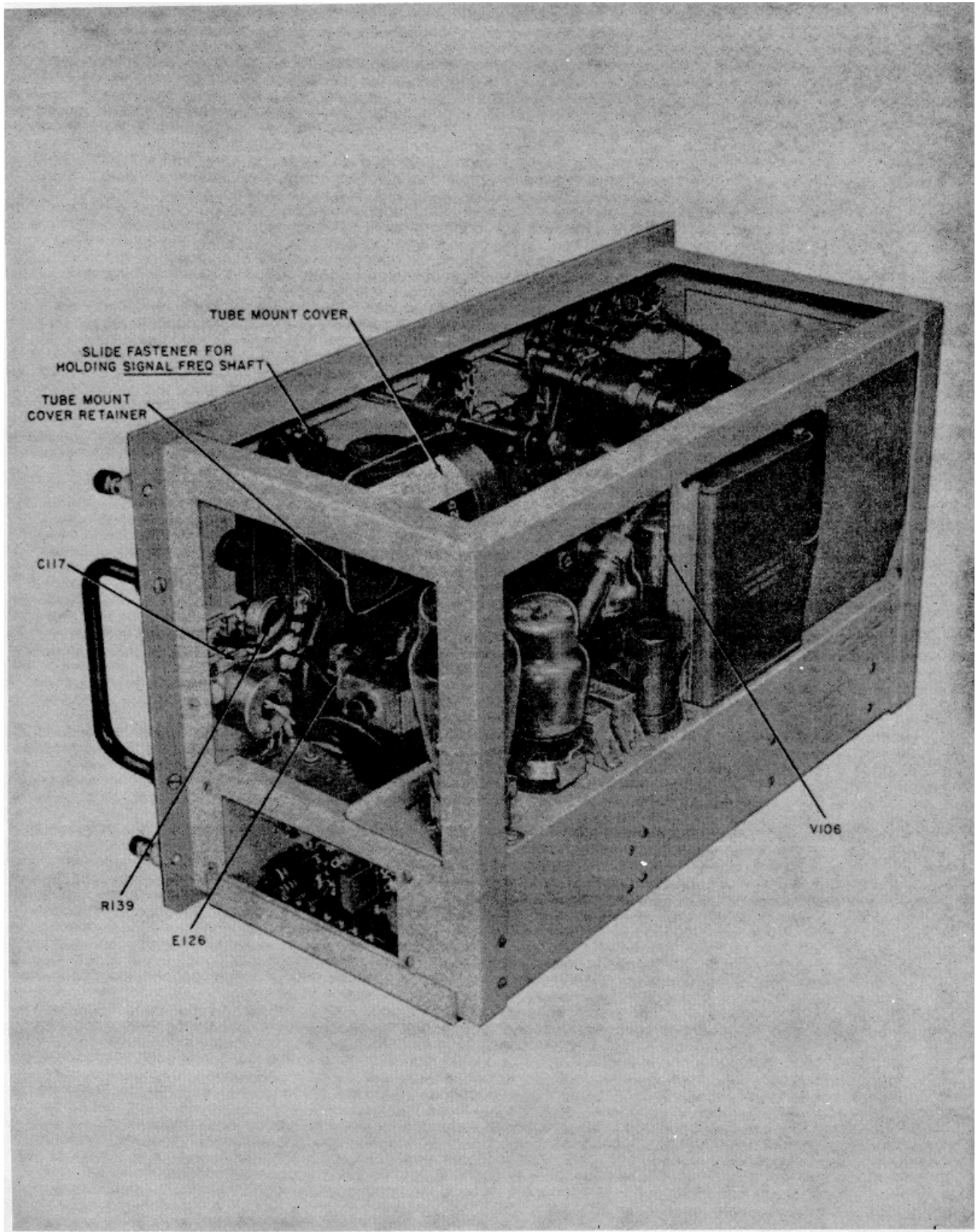

Figure 5-8. Test Set Chassis Right End View

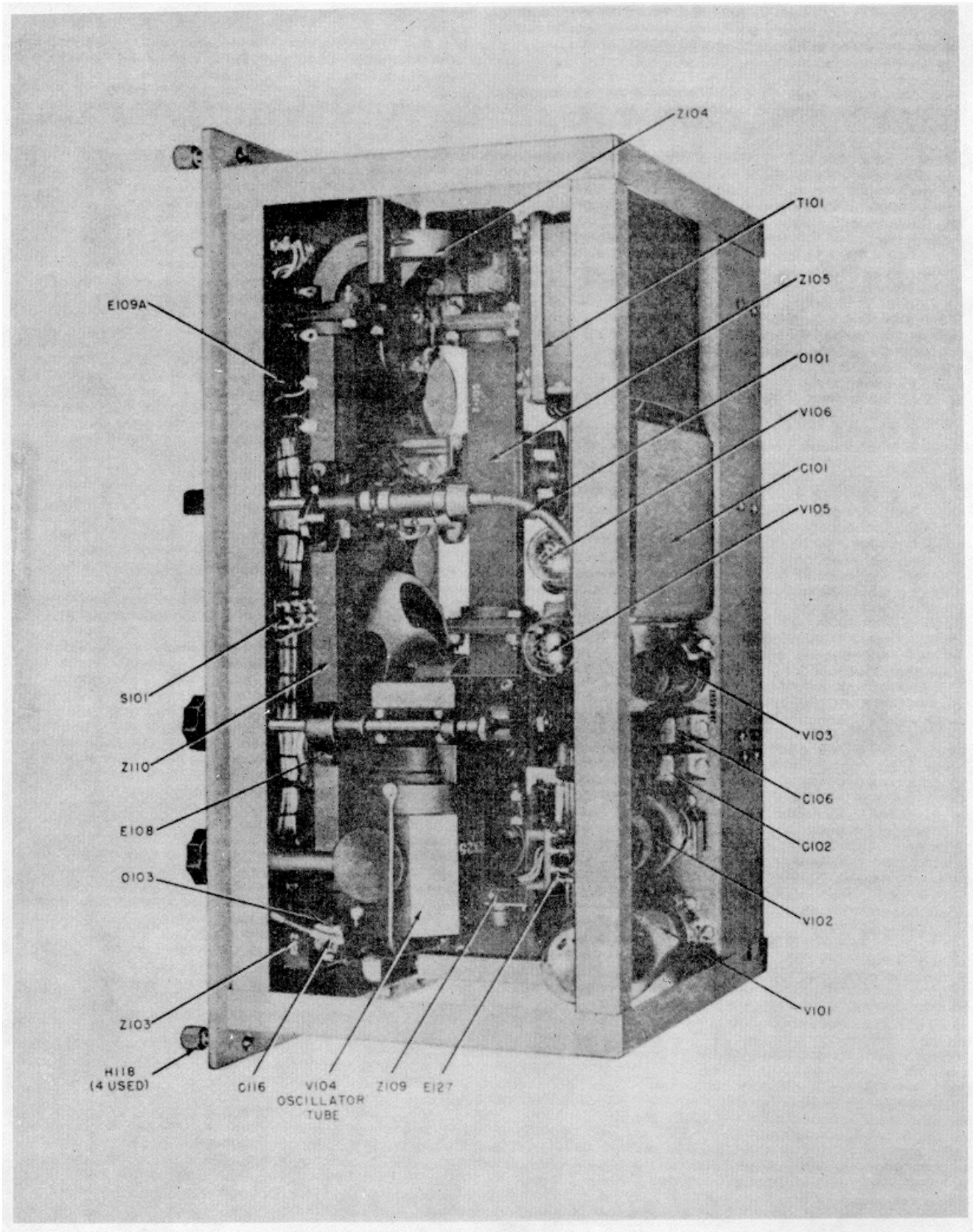

Figure 5-9. Test Set Chassis Top-Rear View

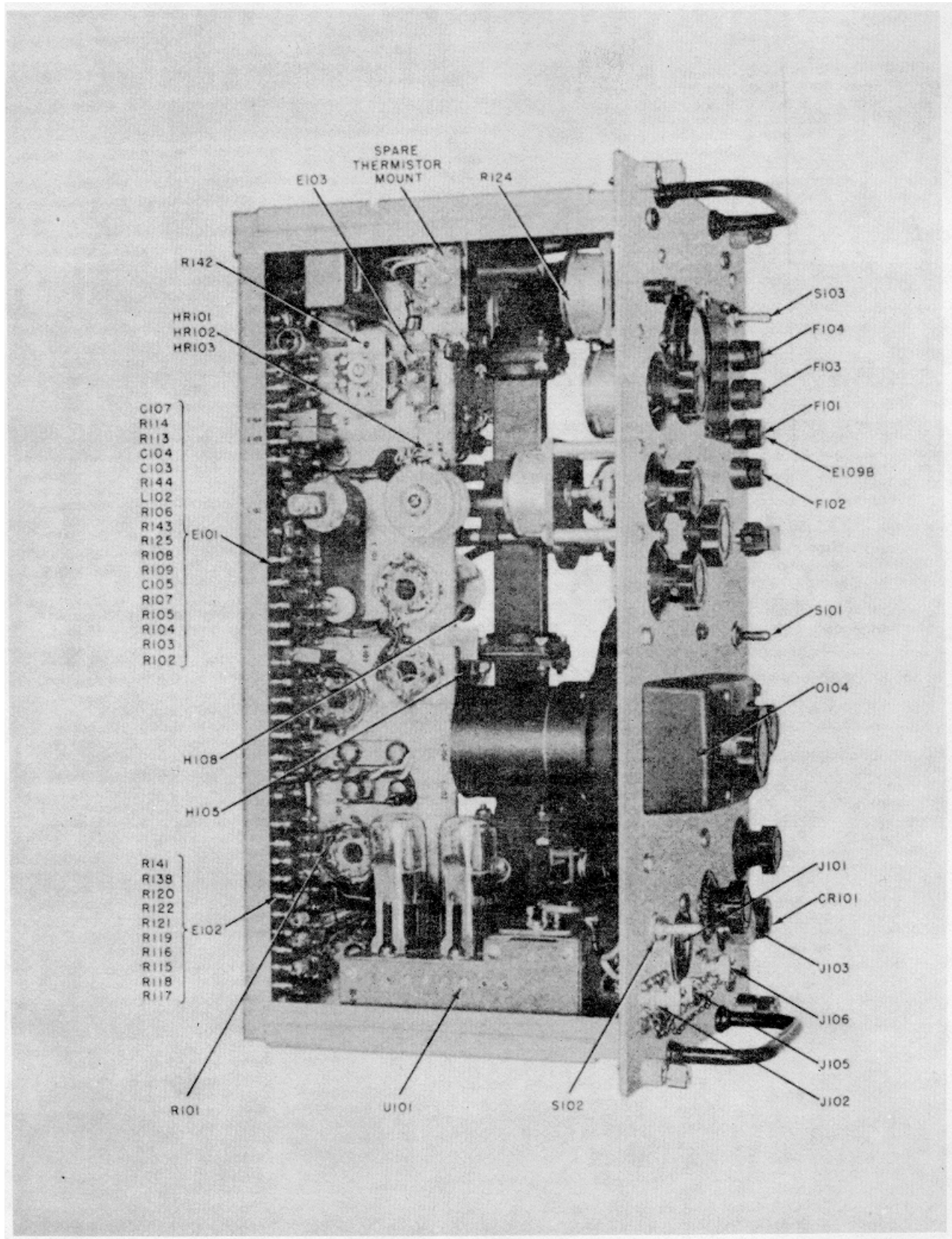

Figure 5-10. Test Set Chassis Bottom-Front View

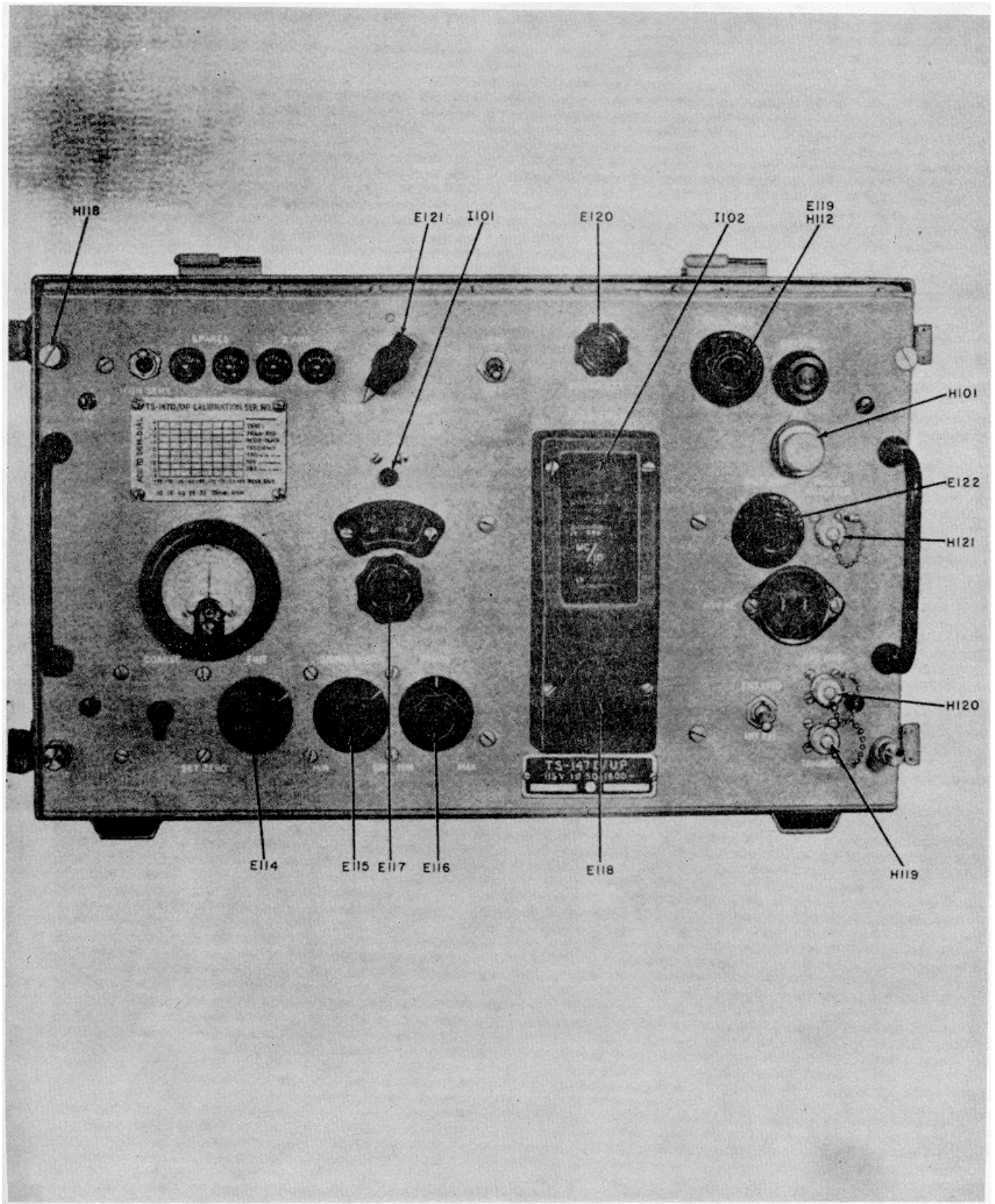

Figure 5-11. Test Set Front Panel View

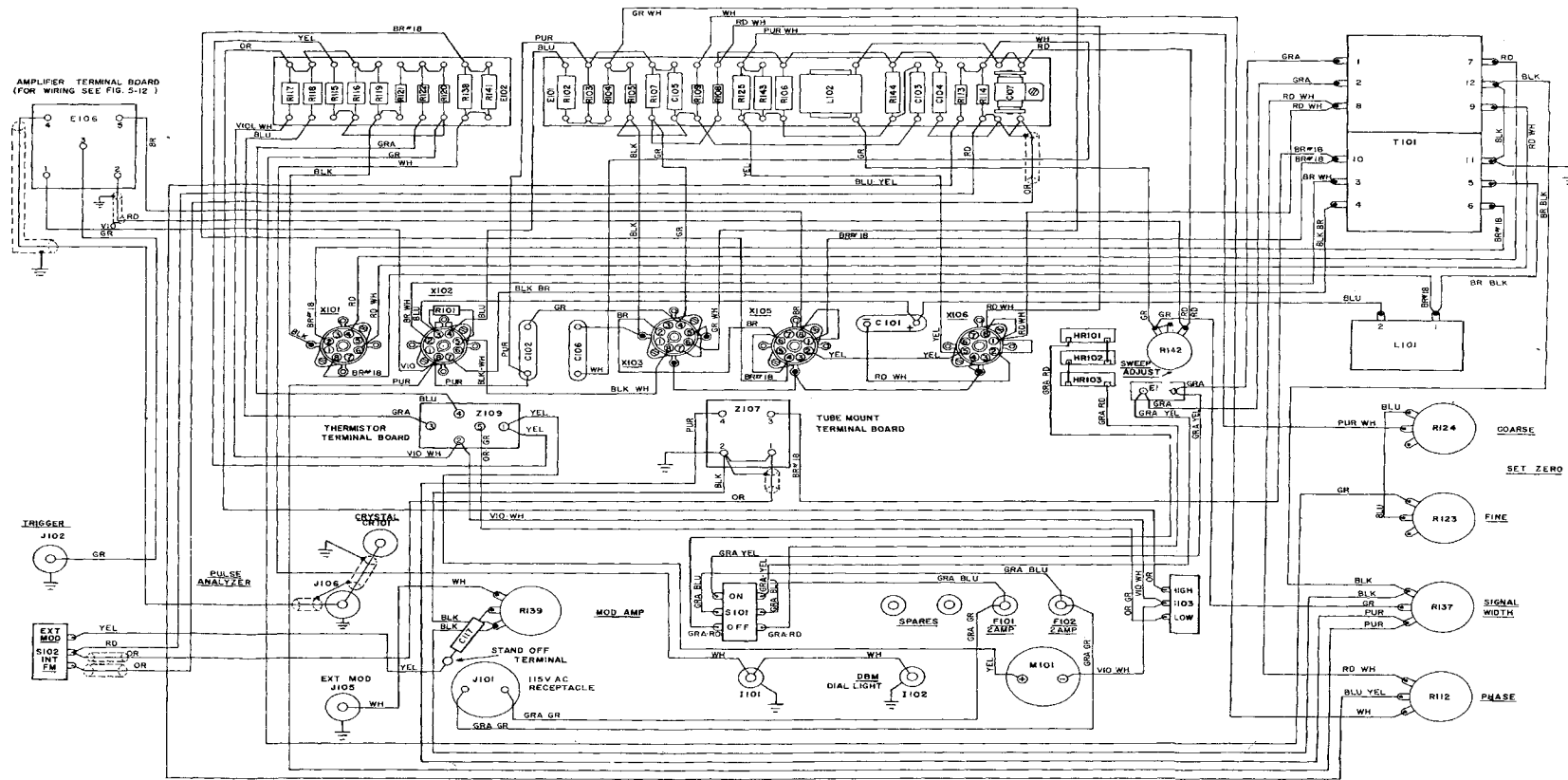

Figure 5-12. Power Supply chassis and Control Panel Wiring Diagram

ORIGINAL

5-17,5-18

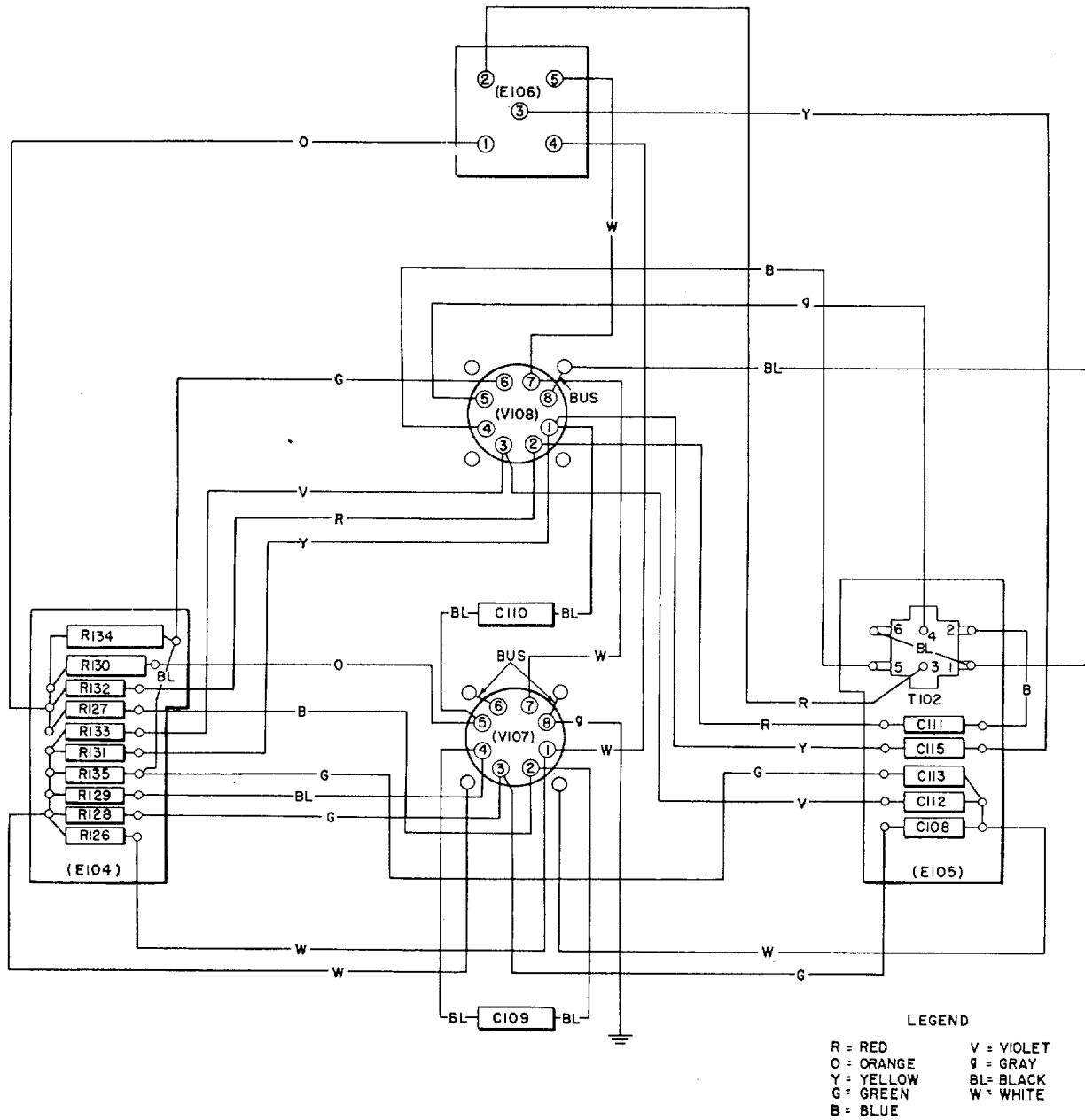

Figure 5-13. Video Amplifier Sub-Assembly, Practical Wiring Diagram

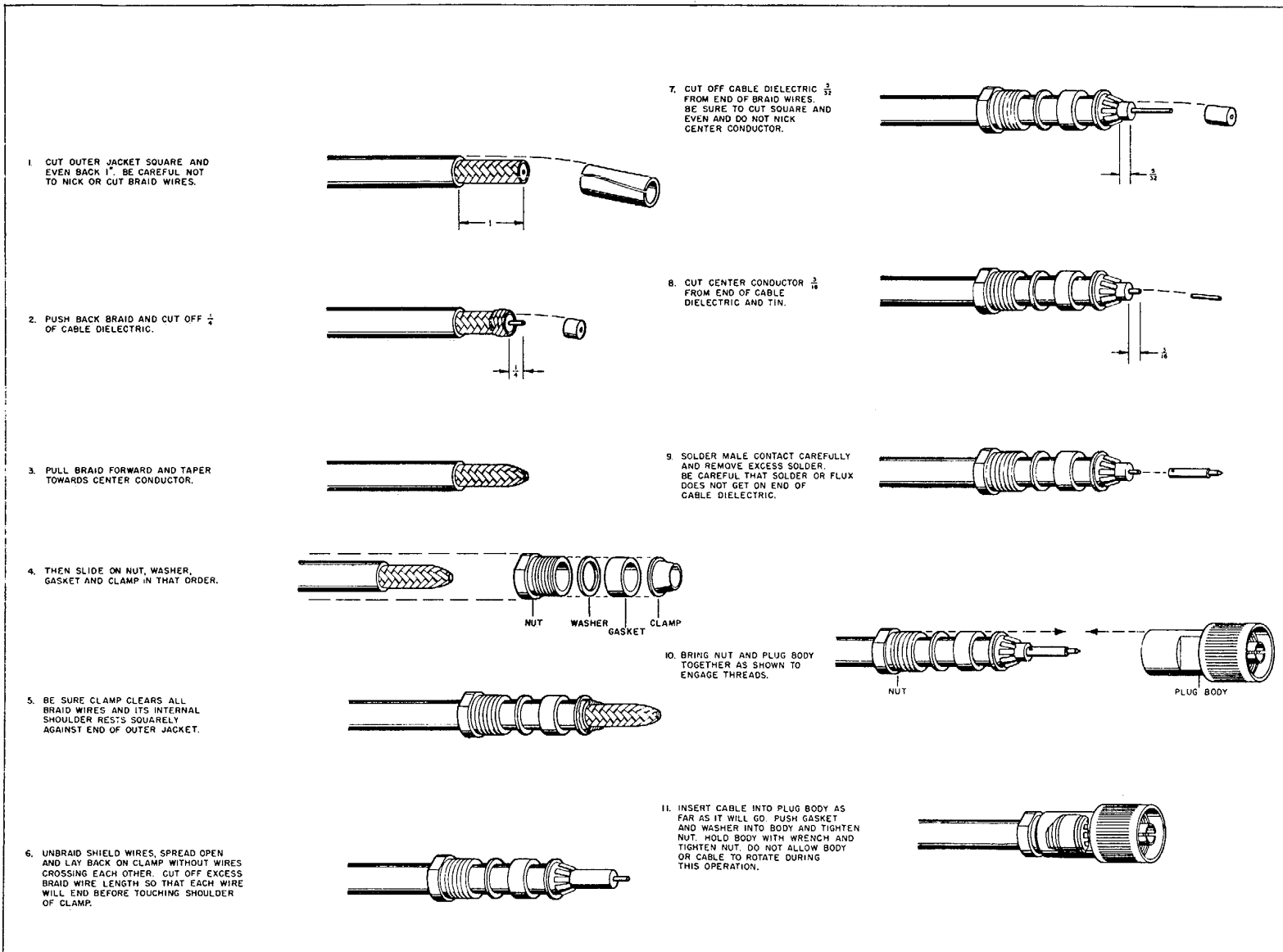
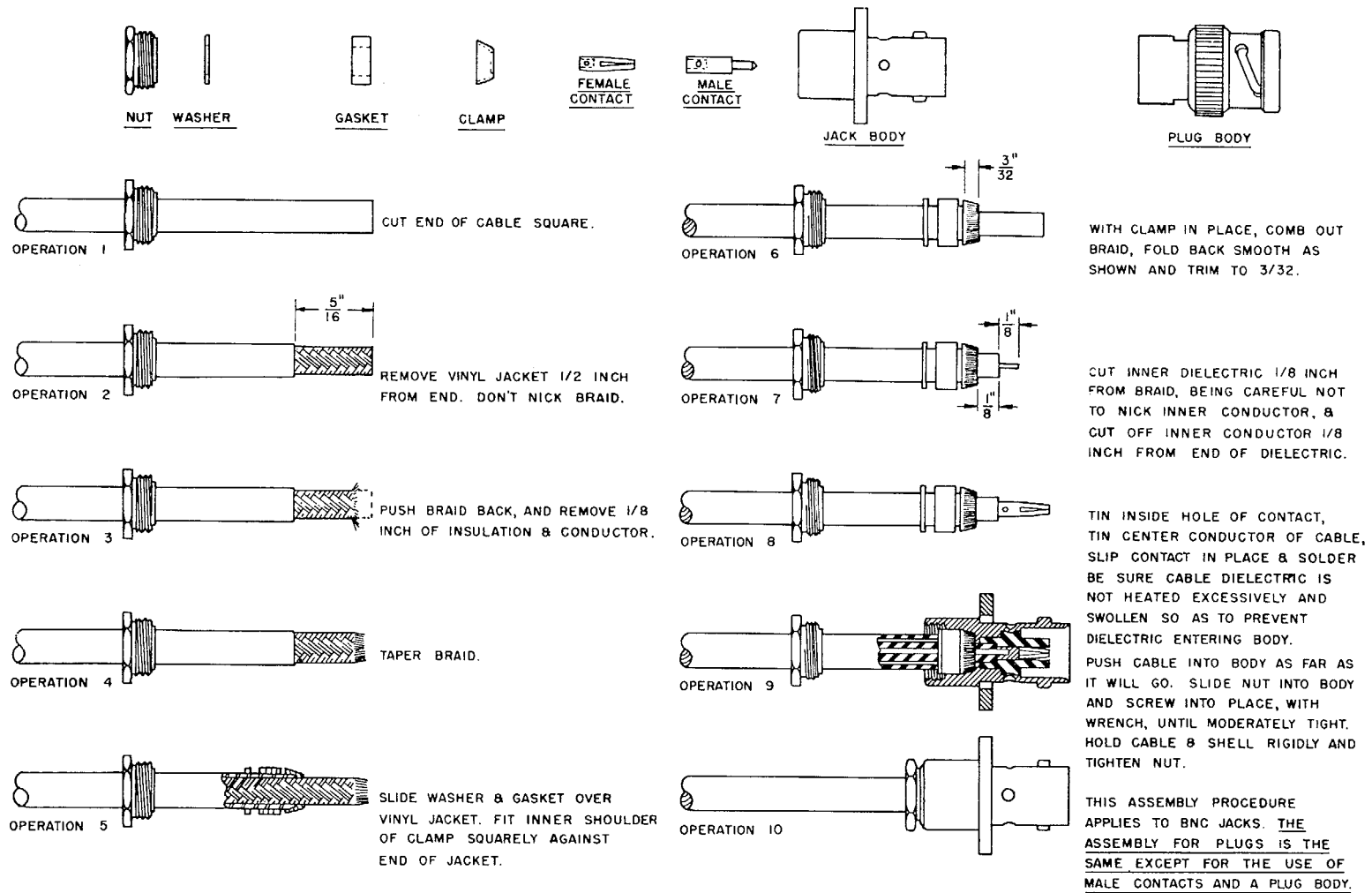

Figure 5-14. Cord CG-92A/U(8'), Fabrication Notes





THE ABOVE PROCEDURE APPLIES TO THE FOLLOWING CABLES.

- RG - 58/U (SINGLE BRAID) 195 O.D.
- RG - 55/U (DOUBLE BRAID) 206 O.D.
- RG - 62/U (SINGLE BRAID) 242 O.D.

Figure 5-15. Assembly of BNC Type Connectors

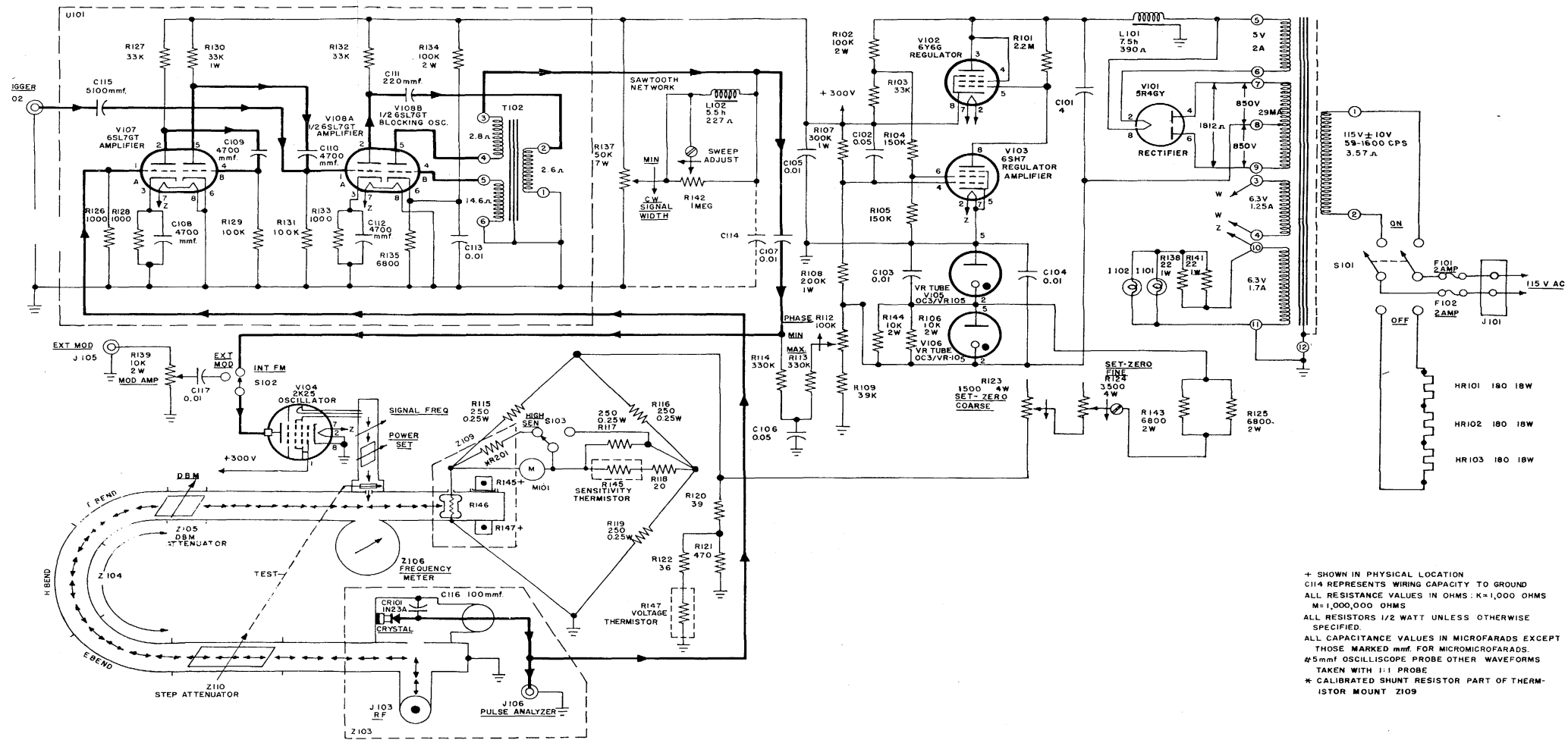

Figure 5-16. Test Set TS-147D/UP Complete System Schematic

SECTION 6  
PARTS LISTS

TABLE 6-1. WEIGHTS AND DIMENSIONS OF SPARE PARTS BOXES

Information Not Available

TABLE 6-2. SHIPPING WEIGHTS AND DIMENSIONS OF SPARE PARTS BOXES

Information Not Available

TABLE 6-3. LIST OF MAJOR UNITS

SYMBOL GROUP	QTY	NAME OF MAJOR UNIT	TYPE DESIGNATION
101 thru 199 and R201	1	Test Set	TS-147D/UP

NOTE: Equipment operates on 115v AC (+ 10%) 59-1600 cycles.

TABLE 6-4. TABLE OF REPLACEABLE PARTS

REF SYM	AF, STD NAVY, SIG CORPS STOCK NUMBER	NAME OF PART AND DESCRIPTION	FUNCTION
<b>STRUCTURAL PARTS</b>			
A101	* - - - - - -	HOUSING, gear drive: aluminum, black anodize finish ; 6-1/4" h x 2-1/2" wd x 1-5/16" deep; has 1-3/8" wd x 2-9/16" lg window; one 5/16"-32 thd hole for grain of wheat type bulb; one 3/8" dia hole to pass tuning shaft; four 0.151" dia mtg holes on 1-7/8" x 4-1/4" ctrs; GCC Dwg P320-C-1057 (C-50448)	Housing for FRE- QUENCY meter drive mechanism
A102	- - - - - -	CASE, test set: Navy type CY-1302A/UP; c/o one combination operating and transit case and one cover; aluminum, light grey enamel finish; outside dimen approx 12-13/16" h x 11" wd x 19-1/2" lg o/a; four feet on bottom of case and four feet on face of case; four inverted "J" type latches, two ea end to retain cover in closed position; case marked "TS-147D/UP" on both ends and front; cover is detachable and has folding flush type handle on top; cover marked "TS-147D/UP" on top; cover has four strikes, two ea end to engage latches on main body of case; GCC Dwg P320-D-412 (D50302)	Combination operating and transit case for Test Set TS-147D/UP
A103	- - - - - -	COVER, test set case: aluminum, light grey enamel finish; hinged; cover removable from case; outside dimen approx 18-7/32" lg x 5-1/2" h x 11-5/16" wd o/a; inside of cover has mounting strip to hold operating spares; strip is covered by hinged plate; plate has List of Contents decal and calibration card mounted on it; four strikes, two ea end, to lock cover in place; cover has flush type folding handle on top; cover marked "TS- 147D/UP" on top; GCC Dwg P320-E-415 (E-50322)	Cover for and p/o Navy type CY-1302A/UP test set case; also serves as container for op- erating spares
<b>CAPACITORS</b>			
C101	3300-317 643 038 - - 3DB4-296	CAPACITOR, fixed: paper; JAN type CP70E1DH405K; 4 mf $\pm$ 10%; 1500 vdcw; JAN-C-25	Power Supply filter
C102	3300-316 163 390 N16-C-44257-2900 3DA50-217	CAPACITOR, fixed: paper; JAN type CP69BIEF503K; 50,000 mmf $\pm$ 10%; 600 vdcw; spec JAN-C-25	R107 bypass
C103	3300-376 143 900 N16-C-33622-5227 3K3510311	CAPACITOR, fixed: mica; JAN type CM35C103K; 10,000 mmf $\pm$ 10%; 300 vdcw; spec JAN-C-5	V105 bypass
C104		Same as C103	V105 and V106 bypass
C105		Same as C103	+300V bypass
C106		Same as C102	PHASE control bypass
C107	3300-317 680 193 N16-C-11252-100 3DA10-484	CAPACITOR, fixed: paper; 10000 mmf +20% -10%; 600 vdcw; HS metal case; 7/16" dia x 1" lg; mineral oil impregnated; axial leads 1-1/2" lg; Aerovox #638MG-.01; include Aerovox clamp #13888-202; GCC Dwg P320-A-1089 (B-50412)	Couple blocking oscil- lator T102 to V104 when S102 is in INT FM position
C108	3300-376 151 835 N16-C-32646-6818 3K3547241	CAPACITOR, fixed: mica; JAN type CM35D472K; 4700 mmf $\pm$ 10%; 500 vdcw; spec JAN-C-5	V107A cathode bypass

\*Not furnished as a maintenance part. If failure occurs, do not request replacement unless the item cannot be repaired or fabricated. Drawing numbers shown in ( ) apply to Contract NObsr 57567.

TABLE 6-4. TABLE OF REPLACEABLE PARTS

REF SYM	AF, STD NAVY, SIG CORPS STOCK NUMBER	NAME OF PART AND DESCRIPTION	FUNCTION
C109		Same as C108	Couple V107A to V107B
C110		Same as C108 Couple	V107B to V108A
C111	3300-376 017 410 N16-C-29370-7606 3K2022142	CAPACITOR, fixed: silver mica; JAN type CM20D221J; 220 mmf $\pm 5\%$ ; 500 vdcw; spec JAN-C-5	Couple V108A to T102
C112		Same as C108	V108A cathode bypass
C113		Same as C103	V108B cathode bypass
C114		CAPACITOR, parasitic; stray wiring capacity, for reference purposes only	Sawtooth charging
C115	3300-376 152 600 N16 C-32720-7533 3K3551232	CAPACITOR, fixed: mica; JAN type CM35C512J; 5100 mmf $\pm 5\%$ ; 500 vdcw; spec JAN-C-5	Couple TRIGGER to V108A
C116	3300-313 889 996 N16-C-99245-7408 3D9100-269	CAPACITOR, fixed: silver mica; button type; 100 mmf $\pm 10\%$ ; 500 vdcw; 0.447" dia ( $\pm 0.010$ ") x 0.070" thick ( $\pm 0.010$ "); solder lug term 9/32" lg at right angle to case; Erie #370BA; GCC Dwg P320-A-457 (A-50599)	Crystal bypass
C117	- - - - 3DA10-505	CAPACITOR, fixed: paper; 10.000 mmf, +20% --10%; 600 vdcw; 0.235" dia x 3/4" lg o/a; axial wire leads, one ea end; Gudeman #XF1811; GCC Dwg P320-A-1094 (CFP-121)	Couple EXT MOD (J105) to V104 when S102 is in EXT MOD position
<b>CRYSTALS</b>			
CR101	*3300-234 137 225 N16-T-51723-5 2J1N23A	CRYSTAL, rectifying; silicon crystal; JAN type 1N23A; spec JAN-1A; GCC Dwg P320-A-349 (XTAL-6002)	Detector
<b>MISCELLANEOUS ELECTRICAL PARTS</b>			
E101	*3300-387 257 796 - - 3Z770-36.6	BOARD, terminal: YN25 phenolic; 38 stand-off solder lug term; w/o barriers; 9-3/16" lg x 1-7/8" wd x 1/8" thick; eleven 9/64" dia mtg holes; GCC Dwg P320-B-357 (B-50420)	Component mounting board
E102	*3300-387 257 414 - - 3Z770-20.14	BOARD, terminal: YN25 phenolic; 20 stand-off solder lug term; w/o barriers; 4-3/8" lg x 1-5/8" wd x 1/8" thick; four 0.140" dia mtg holes on 4" x 7/8" centers; GCC Dwg P320-A-360 (A-50710)	Resistor mounting board
E103	* - - - - - -	BOARD, terminal: YN25 phenolic; 2 stand-off solder lug term; w/o barriers; 1-1/2" lg x 1/2" wd x 1/8" thick; two 0.128" dia mtg holes 1-3/16" center to center; GCC Dwg P320-A-456 (A-50422)	Terminal board
E104	*3300-387 257 210 - - 3Z770-17.10	BOARD, terminal: YN25 phenolic; 17 stand-off solder lug term; w/o barriers; 4-5/8" lg x 2" wd x 1/8" thick; board five 0.140" dia mtg holes; GCC Dwg P320-A-163 (A-50378)	Component mounting
E105	*3300-387 256 610 - - 3Z770-9.10	BOARD, terminal: YN25 phenolic; 9 stand-off solder lug term; w/o barriers; 4-5/8" lg x 2" wd 1/8" thick; five 0.140" dia mtg holes; GCC Dwg P320-A-116 (A-50372)	Component mounting board
*Not furnished as a maintenance part. If failure occurs, do not request replacement unless the item cannot be repaired or fabricated. Drawing numbers shown in ( ) apply to Contract NObstr 57567.			

**PARTS LISTS**

**6 Section  
E106-E116**

*TABLE 6-4. TABLE OF REPLACEABLE PARTS*

REF SYM	AF, STD NAVY, SIG CORPS STOCK NUMBER	NAME OF PART AND DESCRIPTION	FUNCTION
E106	* - - - - - -	BOARD, terminal: YN25 phenolic; 5 stand-off solder lug term; w/o barriers; 2-1/8" lg x 1-3/8" wd x 1/8" thick; two 0.140" dia mtg holes 1-3/4" center to center; GCC Dwg P320-A-114 (A-50380)	Terminal board
E107	* - - - - - -	INSULATOR PLATE: YN25 phenolic; square; 2" lg x 2" wd x 1/8" thick; four 0.154" dia mtg holes on 1-5/8" x 1-5/8" centers; one 13/32" dia shaft hole in center of plate; one 5/32" dia hole 9/16" to left of vert center line to accept "no-slip" pin on resistor (R124) mounted on plate; GCC Dwg P320-A-1064-1 (A-50469-1)	Mount for R124
E108	*3300-287 641 475 - - 2Z3262-36	BLOCK, terminal: D-1 (MP2312) polyiron; four feed-thru type term; w/o barriers; 5/8" lg x 0.805-0.810" wd x 0.493-0.498" high; excluding term; two mtg flanges, one ea end 3/32" deep x 1/16" wd; marked "1" "2" "3" "4" ea side; GCC Dwg P320-B-284 (B-50690)	Tube mount (Z107) terminal assembly
E109	*8800-619 660 N17-F-74266-9081 3Z3282-42.11	HOLDER, fuse: extractor post type; holds one cartridge type fuse 1-1/4" lg x 1/4" dia o/a; black molded phenolic body; copper cont, bright alloy plated; coil spring under cont; 250v, 15 amp; 2-9/64" lg x 11/16" dia o/a; 1/2"-24 thd body for panel mtg in 1/2" dia hole; two solder lug term; cap has hole for test prod; Buss type #HKP; GCC Dwg P320-A-1073 (FH-13004)	Hold F101
E109A	- - - - - -	BODY, fuse holder: extractor post type; holds one cartridge type fuse 1-1/4" lg x 1/4" dia o/a; black molded phenolic body; copper cont, bright alloy plated; coil spring under cont; 250v, 15 amp; 1-19/32" lg x 11/16" dia o/a; 1/2"-24 thd body for panel mtg in 1/2" dia hole; two solder lug term; GCC Dwg P320-A-1073 (FH-13004)	p/o E109
E109B	- - - - - -	CAP, extractor post type fuse holder: black bakelite; copper cont, bright alloy plated for 1/4" dia fuse; bayonet type locking; straight knurl; neoprene gasket 21/32" OD; marked "FUSE" w/ccw arrow in white fill; has hole for test prod; o/a dimen of cap 21/32" dia x 21/32" lg; GCC Dwg P320-A-1073 (FH-13004)	p/o E109
E101		Same as E109	Hold F102
E111		Same as E109	Hold F103
E112		Same as E109	Hold F104
E113	- - - - - -	INSULATOR PLATE: YN25 phenolic; square; 2" lg x 2" wd x 1/8" thick; four 0.154" dia mtg holes on 1-5/8" x 1-5/8" centers; one 13/32" dia shaft hole in center of plate; one 5/32" dia hole 9/16" to left of vert center line to accept "no-slip" pin on resistor (R137) mounted on plate; GCC Dwg P320-A-1064-2 (A-50469-2)	Mount for R137
E114	3300-292 241 228 N16K-E700349-997 2Z5822-77	KNOB, round: black bakelite; fluted, w/skirt; white fill indicator line on skirt; 1-1/2" w X 13/16" h o/a; for 1/4" shaft; phenolic per JAN-P-14' (type MTS-E-1); 8-32 cup point set screw; Harry Davies Mold type #4104; GCC Dwg P320-A-423-1 (KFS-7101)	SET ZERO-FINE
E115		Same as E114	SIGNAL WIDTH
E116		Same as E114	PHASE

\*Not furnished as a maintenance part. If failure occurs, do not request replacement unless the item cannot be repaired or fabricated. Drawing numbers shown in ( ) apply to Contract NObsr 57567.

TABLE 6-4. TABLE OF REPLACEABLE PARTS

REF SYM	AF, STD NAVY, SIG CORPS STOCK NUMBER	NAME OF PART AND DESCRIPTION	FUNCTION
E117	3300-292 103 080 N16-K-700337-327 2Z5748.13	KNOB, round: fluted bakelite; 1-3/8" dia x 11/16" h; phenolic per JAN-P-14 (type MTS-E-1); for 1/4" shaft; 8-32 allen head set screw; Harry Davies Mold #4101; GCC Dwg P320-A-420-2 (KF-7002)	DBM
E118	- - - - - -	KNOB, round: black bakelite; fluted; w/o skirt; 1-5/8" max dia x 3/4" h o/a; 1-3/16" dia base; brass insert for 1/4" shaft; shaft hole 1/2" deep; two 10-32 x 3/8" lg cup point allen head set screws, 90° C to C; Kurz-Kasch #S-309-64-BB; o/a height modified to 5/8" by GCC Dwg P320-A-1090 (A-50452)	FREQUENCY
E119	3300-292 278 380 N16-K-700314-499 2Z5822-353	KNOB, round: black bakelite; fluted, w/skirt; 1-1/2" dia x 13/16" h o/a; for 1/4" shaft; phenolic per JAN-P-14 (type MTS-E-1); 8-32 cup point set screw; Harry Davies Mold items #4100C and #4110 make one Harry Davies Mold type #4104; skirt modified per GCC Dwg P320-A-423-2 (A-50451) to include word INCREASE w/ccw arrow	SIGNAL FREQ
E120	3300-292 242 525 N16-K-700349-995 2Z5843.27	KNOB, round: black bakelite; fluted; phenolic per JAN-P-14 (type MTS-E-1); for 1/4" dia shaft; brass insert; two 8-32 allen head set screws 3/16" lg; 1-1/8" dia x 5/8" h o/a; Harry Davies Mold #4100, Cut 2, Style 1; GCC Dwg P320-A-420-1 (KF-7001)	POWER SET
E121	3300-218 388 000 N16-K-700065-575 2C4529/K1	KNOB, bar type: black bakelite; flared base; nickel pl pointer; 1-1/4" lg (incl pointer) X 3/4" w (inci flare) x 5/8" h; two 8-32 allen hd set screws, one 1/4" lg, one 7/16" lg; for 1/4" dia shaft; Nat'l Co. type #HRP-P; GCC Dwg P320-A-421 (KPB-7204)	TEST
E122	- - - - - -	KNOB, round: black bakelite; fluted, w/skirt; 1-1/2" dia x 13/16" h o/a; for 1/4" shaft; phenolic per JAN-P-14 (type MTS-E-1) 8-32 cup point set screw; Harry Davies Mold items #4100C and #4110 make one Harry Davies Mold type #4104; skirt modified per GCC Dwg P320-A-423-3 (A-50451-2) to include word INCREASE w/ccw arrow	MOD AMP
E123	- - - - 2Z308-446	ADAPTER, coaxial to waveguide: ANA type UG-446/U for adapting coaxial type N male plug to RG-52/U waveguide equipped w/UG-39/U cover flange; coupling loss zero db; terminated one end w/ANA type UG-39/U square flange, ANA type N female other end, seeing approx 50 ohms impedance; ASES A Dwg AS-2031; GCC Dwg P320-C-1105 (C-50733)	Accessory, u/w W101
E124	- - - - - -	ADAPTER, coaxial to waveguide: ANA type UG-397/U; for adapting coaxial type N RF plug to RG-51/U waveguide equipped with UG-52A/U cover flange; coupling loss zero db; terminated one end with type UG-51/U square flange, other end ANA type N female jack, seeing approx 50 ohm impedance; ASES A Dwg AS-2022; GCC Dwg P320-C-1097 (C-50742)	Accessory, u/w W101
E125	- - - - - -	ADAPTER, connector: BNC to UHF; one rd male contact one end, one slotted female cont other end; 1.206" lg x 23/32" dia o/a; cylindrical brass body, silver pl; teflon insert (Rexolite or GE-1422); mounts to mating connectors by 5/8"-23 int thd coupling ring w/straight knurl male end, and by bayonet keys female end; ANA type UG-273/U; GCC Dwg P320-A-1116 (A-50731)	Adapter from UHF to BNC

Drawing numbers shown in ( ) apply to Contract NObsr 57567.

## PARTS LISTS

Section 6  
E126-H112

TABLE 6-4. TABLE OF REPLACEABLE PARTS

REF SYM	AF, STD NAVY, SIG CORPS STOCK NUMBER	NAME OF PART AND DESCRIPTION	FUNCTION
E126	- - - - - -	BOARD, terminal: three stand-off solder lug term; YN25 sheet phenolic; 1-1/4" lg x 7/8" wd x 3/32" thk; 0.128" dia mtg holes on 1" x 5/8" ctr; GCC Dwg P320-A-73 (A-50634)	Mount for R201
E127	- - - - - -	BOARD, terminal: five stand-off solder lug term; YN25 sheet phenolic; 1-1/4" lg x 7/8" wd x 3/32" thk; 0.128" dia mcg holes on 1" X 5/8" ctr; GCC Dwg P320-A-1083 (A-50639)	Thermistor mount terminal board
<b>FUSES</b>			
F101	- - - - - -	FUSE, cartridge: one-time; 2 amp, 250v; glass tube; nickel pl cont; 1-1/4" lg x 1/4" dia Littlefuse type #3 AG; catalog item #312002; GCC Dwg P320-A-1095 (A-50444)	Power
F102		Same as F101	Power
F103		Same as F101	Spare
FJ04		Same as F101	Spare
<b>HARDWARE</b>			
H101	*3300-651 757 916 N43-N-10157-560 6L3410-24-16.1	NUT, special: brass, nickel pl; 1" dia x 1/8" thk; csk to 41/64" dia; 13/16" across flats; GCC Dwg P320-A-408 (A-50454)	Hold output section to front panel
H102	- - - - - -	WRENCH, alien: for #10 allen screw; socket; hexagonal; 1-29/32" lg w/right angle elbow 3/4" lg; 0.0937" across flats; GCC Dwg P320-A-196 (KEY-13018)	Tool
H103	- - - - - -	WRENCH, allen: for #8 allen screw; socket; hexagonal; 1-25/32" lg w/right angle elbow 25/32" lg; 0.0781" across flats; GCC Dwg P320-A-197 (KEY-13017)	Tool
H104	3300-287 178 460 N16-C-301806-457 2Z2642.233	CLAMP, tube: spring steel, nickel pl; 0.020" thk; L-shaped; long leg 1-3/8" lg; short leg 3/8" lg; 0.156" dia mtg hole; GCC Dwg P320-A-105 (A-50424)	Hold V103
H105	3300-287 178 461 N16-C-302568-708 2Z2642.234	CLAMP, tube: spring steel, nickel pl; 0.020" thk; L-shaped; long leg 1-27/32" lg; short leg 3/8" lg; 0.156" mtg hole; GCC Dwg P320-A-106 (A-50382)	Hold V105
H106	3300-287 172 845 N16-C-300798-866 2Z2642.336	RETAINER, tube: 302 SS; closed dia 1-3/8" x 3/4" h; mtg bracket w/clearance for #10 mach screw located 120° from ctr line of retainer; strap 0.025" thk; clip 0.025" thk; bracket 0.035" thk; open radius 1-9/16"; Britcher type #926C; GCC Dwg P320-A-1093 (CLT-3601)	Hold V101
H107		Not used	
H108		Same as H105	Hold V106
H109		Same as H105	Hold V107
H110		Same as H105	Hold V108
H111		Same as H106	Hold V102
H112	*3300-295 559 957 - - - -	SHAFT ASSEMBLY, tuning: c/o knob E119 and one piece XXX bakelite rod 2.463" lg x 1/4" dia; one end cut square to 0.190" with 1/64" X 450 chamfer for 0.349" and fitted with hard sq seamless brass tube sleeve 1/4" sq x 19/32" lg x 0.025" thk wall; sleeve held on with	Klystron (V104) tuning device

\*Not furnished as a maintenance part. If failure occurs, do not request replacement unless the item cannot be repaired or fabricated. Drawing numbers shown in ( ) apply to Contract NObsr 57567.



TABLE 6-4. TABLE OF REPLACEABLE PARTS

REF SYM	AF, STD NAVY, SIG CORPS STOCK NUMBER	NAME OF PART AND DESCRIPTION	FUNCTION
H113	3300-291 618 147 N17-G-154211-607 2Z4868.703	type 303 SS pin 0.047" dia; other end fitted with type 303 SS extension 1.254" lg x 3/8" OD (max); largest dia drilled 1/4" deep x 0.2350" ctb; other end of extension has 1/64" x 45° chamfer and fits into E119; extension secured to bakelite rod with type 303 SS pin 0.386" lg x 0.094" dia; GCC Dwg P320-A-458 (A-50694)  GASKET, brass: silver pl; 1-5/8" x 1-5/8" x 0.003" thk; inside dim. 0.920" x 0.420"; four 0.193" dia holes on 1.220" x 1.280" ctrs; (9 used); GCC Dwg P320-A-28 (A-50596)	Used for wave guide flange connections
H114	3300-291 618 148 N17-G-161913-871 2Z4868.704	GASKET, polyiron: 2.525" OD; 2.230" ID; 0.156" thk; GCC Dwg P320-A-260 (A50679)	Leakage protection for Z107
H115 thru HI 17		Not used	
H118	* - - - - - -	BOLT, REDUCED SHANK: stainless steel; knurled thumb head w/screwdriver slot; 10-24 NC-2 X 1/2" lg; 1-3/8" lg o/a; head 9/16" dia x 3/8" thk; 4 used; GCC Dwg P320-A-1011 (A-50706)	Captive screw to hold panel
H119	- - N17-C-200964-601 - -	COVER, ELECTRICAL CONNECTOR: brass, silver pi; 1/2" dia x 5/8" lg w/cork pad; bead chain 2-1/2" lg w/3/16" secure hole; for BNC connectors; Navy Dwg RE49F331; ANA type CW-123/U; Gen RF Fitting Co catalog item #9; GCC Dwg P320-A-1076 (CAP-12001)	Cover for J102
H120	Same as H119	Cover for J105	
H121	Same as H119	Cover for J106	
<b>HEATERS</b>			
HR01	- -	HEATER, resistor: wirewound; 158 ohm ± 10%; 24 watts; circular ceramic base; 1-3/8" dia x 3/8" thk; 2 solder lug term; one 0.196" dia mtg hole center of base; WL #24D180; GCC Dwg P320-A-377 (A-50410)	Standby heater
HR102		Same as HR101	Standby heater
HR103		Same as HR101	Standby heater
<b>LAMPS</b>			
I101	8800-443 685 - - 2Z5932	LAMP, incandescent: 3v; 150 ma; grain of wheat type GE #323; GCC Dwg P320-A-157 (LI-5700)	Scale illuminator DBM Attenuator Z105
I102		Same as I101	Scale illuminator Frequency Meter Z106
<b>CONNECTORS</b>			
J101	8850-017 400 - - 6Z7589	CONNECTOR, male contact: 2 flat parallel blades; straight; 1-3/8" dia mtg hole; 2.031" dia x 1.062" deep o/a; 15 amp 125v; cylindrical steel body; cable opening 0.406"; two 0.136" screw holes on 1-3/4" mtg ctr; Hubbell #6808; GCC Dwg P320-A-410 (A-50466)	115v AC power input

\*Not furnished as a maintenance part. If failure occurs, do not request replacement unless the item cannot be repaired or fabricated. Drawing numbers shown in ( ) apply to Contract NObsr 57567.

TABLE 6-4. TABLE OF REPLACEABLE PARTS

REF SYM	AF, STD NAVY, SIG CORPS STOCK NUMBER	NAME OF PART AND DESCRIPTION	FUNCTION
J102	- - N17-C-73108-1267 RE 49F331E;	CONNECTOR, female cont: BNC type; l rd slotted socket cont; straight box mtg type; 1-1/16" sq o/a; Navy Dwg sq mtg plate; four 3-56 tap mtg holes on 0.500" mtg/c; 2 keys for bayonet locking on mating end; solder lug term on other end; ANA type UG-290/U; General RF Fitting Co catalog item #4; GCC Dwg P320-A-1077 (CONF-12007)	TRIGGER input
J103		CONNECTOR, receptacle: female contact; part of Z103, for reference purposes only	RF In/Out
J104	- - - - 6Z3150-4	CONNECTOR, receptacle: female cont; black bakelite; 10 amp, 250v; 15 amp, 125v; 1.375" dia x 1.218" h; w/cord grip; Hubbell #7257; GCC Dwg P320-A-432 (A-50721)	AC power connector, p/o W103
J105		Same as J102	EXT MOD input
J106		Same as J102	PULSE ANALYZER output
<b>INDUCTORS</b>			
L101	3300-308 034 039 N16-R-29184-6745 3C575-35	REACTOR, AF: single winding; 7.5 hy +15% - 5%; 0.045 amp DC; 390 ohm DC $\pm$ 10%; 2-7/8" lg x 1-7/8" w x 1-3/4" h; fosterite finish; finish increases o/a dim. approx 1/16"; four 0.166" dia mtg holes on 2-7/16" x 1-7/16" mtg/c; GCC Dwg P320-B-23 (B-50404)	Power supply filter
L102	3300-308 034 040 N16-R-29098-6529 3C575-36	REACTOR, AF: single winding; 5.5 hy +20% -10%o; no DC; 10v AC; 227 ohm $\pm$ 10%; 1-3/16" lg x 15/16" w x 3/4" thk; fosterite finish; finish increases o/a; dim. approx 1/16"; GCC Dwg P320-B-22 (B-50413)	Sweep adjust choke
M1i01	- - - - - -	METER, ammeter: 1501-0-50 ua dc; +2% accuracy of full scale deflection; 75 ohm $\pm$ 1 ohm at 25°C; round annealed sheet steel ruggedized flush mtg case hermetically sealed, filled with dry nitrogen gas; barrel 2.210" dia, 1.670" behind flange; flange 2-3/4" dia; spl scale black on white; three 1/8" mtg holes on 1.220" rad 120' apart; 2 soldering lugs; Weston model #1521; GCC Dwg P320-A-1014 (C-50461)	Bridge current indicator
<b>MECHANICAL PARTS</b>			
0101	3300-295 559 943 N16-C-92316-3431 2Z8204-132	SHAFTING, flexible: bronze; interlocking flexible phosphor bronze casing; two slotted female fittings, one ea end; two 1/2"-20 NF-3 thd coupling nuts, one ea end; 7-3/8" lg (incl female fittings) x 1/4" dia (measured at female fittings); White SS end, fitting #3181, casing #169A3, cable #130R37, nut #3182, and end fitting for shaft #2325; GCC Dwg P320-B-141 (B-50595)	Operate RF cutoff of Z106 from E121
0102	3300-287 690 270 N17-C-98378-4115 2ZK3290..11	COUPLING, flexible: ceramic insulation; phosphor bronze spring, nickel pl; peak flash over 3700v; 1-9/32" dia (including springs) X 3/4" thk; for 1/4" shaft; four 6-32 allen hd set screws 5/32" lg; Millen #39002; GCC Dwg P320-A-401 (A-50471)	Coupling for SIGNAL WIDTH knob and potentiometer R137
0103	3300-295 757 258 N16-B-800139-625 2Z8634-4	BUSHING, polyiron: 0.372" OD; 0.125" ID; 0.125" thk; GCC Dwg P320-A-43 (A-50598)	Under C116; minimize RF leakage; p/o Z103

Drawing numbers shown in () apply to Contract NObsr 57567.

TABLE 6-4. TABLE OF REPLACEABLE PARTS

REF SYM	AF, STD NAVY, SIG CORPS STOCK NUMBER	NAME OF PART AND DESCRIPTION	FUNCTION
0104	* - - - - - -	DRIVE, tuning: manually operated; multi-position; includes one floating gear, one drive gear, one pinion and housing for pinion; floating gear and drive gear secured to each other and have 48 teeth 32 pitch, 14-1/2' P.A. and 1-1/2" P.D.; drive gear has 3/16" face and 1/4" lg x 1/2" dia hub; hub has 1/4" dia ctr hole; floating gear has 1/16" face w/approx 1/2" dia ctr hole; pinion is approx 27/32" lg x 19/32" dia o/a; pinion has 16 teeth, 32 pitch, 14-1/2. P.A. and 1/2" P.D.; pinion housing has four 3/16" dia mtg holes on 1/2" x 1.187" ctrs; drive gear assembly is GCC Dwg/Part P320-A-1040 (A-50432); pinion assembly is GCC Dwg/Part P320-A-1030 (A-50478)	Drive mechanism for tuning FREQUENCY meter
P101		<b>CONNECTORS</b>	
P102	- - N17-C-71408-3748 2Z7390-260	Not used	
P103		CONNECTOR, plug: male conts; one rd contact; locking BNC bayonet sleeve; straight type; 31/32" lg x 27/64" dia; low power, 500v rating; cylindrical brass body, silver pl; brass contact, silver pl; nonconstant frequency impedance characteristic; 0.258" cable opening; Rexolite (GE) 1422 machined insulator insert; solder term one end; ANA type UG-260/U, Navy Dwg RE49F380, Spec ASEA Bulletin 49-2A (NAVSHIPS 900-102B); GRFF catalog item #1; GCC Dwg P320-A-1075 (CONM-12004)	p/o W102
P104	- - - - 2Z7390-21B	Same as P102	p/o W102
P105		CONNECTOR, plug: type N; female contact; one rd contact; straight; 1-7/8" lg x 13/16" dia; 5/8"-24 cplg thd; constant frequency impedance characteristics; cylindrical brass body, silver pl; for use with standard 50 ohm impedance cable; Gen RF Fitting Co catalog item #202; ANA type UG-21B/U	p/o W101
P106	- - N17-C-71426-2729 6Z1727-2	Same as P104	p/o W101
R101	3300-381 168 240 N16R-51065-0811 3RC20BF225K	CONNECTOR, plug: male conts; 2 flat parallel blades; 10 amp, 250v; 15 amp, 125v; 1-17/32" dia x 1-27/32" lg o/a; w/cable clamp; Navy type 49825; Hubbell type #7057; GCC Dwg P320-A-433 (A-50722)	AC power connector, p/o W103
		<b>RESISTORS</b>	
R102	3300-381 168 240 N16R-51065-0811 3RC20BF225K	RESISTOR, fixed: composition; JAN type RC20BF225K; 2.2 meg $\pm$ 10%; 1/2w; spec JAN-R-11	V102 grid voltage divider
R103	3300-381 516 220 N16-R-50634-505 3RC42BE 104K	RESISTOR, fixed: composition; JAN type RC42BE104K; 100,000 ohm $\pm$ 10%; 2w; spec JAN-R-11	V103 screen voltage divider
R104	3300-381 168 960 N16-R-50417-0811 3RC20BF333K	RESISTOR, fixed: composition; JAN type RC20BF333K; 33,000 ohm $\pm$ 10%; 1/2w; spec JAN-R-11	V103 screen voltage divider
R104	3300-381 167 200 N16-R-50678-0811 3RC20BF154K	RESISTOR, fixed: composition; JAN type RC20BF154K; 150,000 ohm $\pm$ 10%; 1/2w; spec JAN-R-11	V103 screen voltage divider

\*Not furnished as 'a maintenance part. If failure occurs, do not request replacement unless the item cannot be repaired or fabricated. Drawing numbers shown in ( ) apply to Contract NObsr 57567.

**PARTS LISTS**

**Section 6  
R105-R122**

TABLE 6-4. TABLE OF REPLACEABLE PARTS

REF SYM	AF, STD NAVY, SIG CORPS STOCK NUMBER	NAME OF PART AND DESCRIPTION	FUNCTION
R105		Same as R104	V103 screen voltage divider
R106	3300-381 516 160 N16-R-50283-535 3RC42BE103K	RESISTOR, fixed: composition; JAN type RC42BE103K; 10,000 ohm ± 10%; 2w; spec JAN-R-11	V105, V106 bleeder
R107	3300-381 318 720 N16-R-50749-0751 3RC30BF304J	RESISTOR, fixed: composition; JAN type RC30BF304J; 300,000 ohm ±5%; 1w; spec JAN-R-11	V103 grid voltage divider
R108	3300-381 317 860 N16-R-50704-0751 3RC30BF204J	RESISTOR, fixed: composition; JAN type RC30BF204J; 200,000 ohm ±5%; 1w; spec JAN-R-11	V103 grid voltage divider
R109	3300-381 169 380 N16-R-50444-0811 3RC20BF393K	RESISTOR, fixed: composition; JAN type RC20BF393K; 39,000 ohm ±10%; 1/2w; spec JAN-R-11	PHASE control voltage divider
R110		Not used	
R111		Not used	
R112	3300-399 810 005 N16-R-88011-8717 3Z7480-131	RESISTOR, variable: composition; 100,000 ohm ±20%; 1/2w; 100°C max continuous operation; 3 solder lug term; enclosed metal case; 1-1/4" dia x 9/16" deep; linear (U) taper; SS shaft 1/4" dia x 7/8" lg; 3/8"-32 bushin- x 3/8" lg; CTS Type 35; GCC Dwg P320-B-399 (B-50467)	PHASE control
R113	3300-381 169 020 N16-R-50759-0811 3RC20BF334K	RESISTOR, fixed: composition; JAN type RC20BF334K; 330,000 ohm ± 10%; 1/2w; spec JAN-R-11	p/o Phase Control circuit
R114		Same as R113	V104 reflector coupler
R115	-- -- --	RESISTOR, fixed: wirewound; 250 ohms, 11%; 0.25w ((ri 40°C ambient temperature; ceramic core; 13/32" lg x 9/32" dia; two AWG #22 wire leads one each end at right angles to body; IRC type WW10; GCC Dwg P320-A-1086 (A-50708)	Bridge circuit
RI 16		Same as R115	Bridge circuit
R117		Same as R15	Bridge sensitivity
R118	3300-381 167 780 N16-R-49309-0431 3RC20BF200J	RESISTOR, fixed: composition; JAN type RC20BF200J; 20 ohm ±5%; 1/2w; spec JAN-R-11	Bridge compensating
R119		Same as R115	Bridge circuit
R120	3300-381 169 240 N16-R-49390-0431 3RC20BF390J	RESISTOR, fixed: composition; JAN type RC20BF390J; 39 ohm ±5%; 1/2w; spec JAN-R-11	Bridge voltage divider
R121	3300-381 169 660 N16-R-49768-0431 3RC20BF47 1J	RESISTOR, fixed: composition; JAN type RC20BF471J; 470 ohm ±5%; 1/2w; spec JAN-R-11	Bridge voltage divider
R122	3300-381 169 120 N16-R-49381-0431 3RC20BF360J	RESISTOR, fixed: composition; JAN type RC20BF360J; 36 ohm ±5%; 1/2w; spec JAN-R-11	Bridge compensating

Drawing numbers shown in ( ) apply to Contract NObsr 57567.

## PARTS LISTS

Section 6  
R123-R140

TABLE 6-4. TABLE OF REPLACEABLE PARTS

REF SYM	AF, STD NAVY, SIG CORPS STOCK NUMBER	NAME OF PART AND DESCRIPTION	FUNCTION
R123	3300-380 078 130 - - 3RA7813	RESISTOR, variable: wirewound; JAN type RA30A1FD-152AD 1500 ohm $\pm$ 10%; 4w; spec JAN-R-19	SET ZERO-FINE control
124	3300-380 066 080 N16-R-90932-0216 3RA6608	RESISTOR, variable: wirewound; JAN type RA30A1SA-352AK; 3500 ohm $\pm$ 10%; 4w; spec JAN-R-19	SET ZERO-COARSE control
R125	3300-381 520 580 N16-R-50202-521 3RC42BE682K	RESISTOR, fixed: composition; JAN type RC42BE682K; 6800 ohm $\pm$ 10%; 2w; spec JAN-R-11	SET ZERO voltage divider
R126	3300-381 166 100 N16-R-49922-0811 3RC20BF102K	RESISTOR, fixed: composition; JAN type RC20BF102K; 1000 ohm $\pm$ 10%; 1/2w; spec JAN-R-11	V107A grid leak
R127		Same as R103	V107A plate load
R128		Same as R126	V107A cathode bias
R129	3300-381 166 220 N16-R-50633-0811 3RC20BF104K	RESISTOR, fixed: composition; JAN type RC20BF104K; 100,000 ohm $\pm$ 10%; 1/2w; spec JAN-R-II	V107B grid leak
R130	3300-381 318 960 N16-R-50418-0231 3RC30BF333K	RESISTOR, fixed: composition; JAN type RC30BF333K; 33,000 ohm $\pm$ 10%; lw; spec JAN-R-i1	V107B plate load
R131		Same as R129	V108A grid leak
R132		Same as R103	V108A plate load
R133		Same as R126	V108A cathode bias
R134		Same as R102 vider	V108B bias voltage divider
R135	3300-381 170 580 N16-R-50201-0811 3RC20BF682K	RESISTOR, fixed: composition; JAN type RC20BF682K; 6800 ohm $\pm$ 10%; 1/2w; spec JAN-R-11	V108B cathode bias
R136		Not used	
R137	3300-380 084 030 - - 3RA8403	RESISTOR, variable: wirewound; JAN type RA40A1FD-503AK; 50,000 ohm $\pm$ 10%; 7w; spec JAN-R-19	SIGNAL WIDTH control
R138	3300-381 317 940 N16-R-49320-0231 3RC30BF220K	RESISTOR, fixed: composition; JAN type RC30BF220K; 22 ohm $\pm$ 10%; lw; spec JAN-R-11	Voltage dropping for 3v pilot lamps
R139	- - - - - -	RESISTOR, variable: composition; 10,000 ohm +20%; 2w; (U) linear taper; 3 solder lug term; 1-1/16" dia x 1-9/16" lg (incl shaft); 3/8"-32 thd bushing 3/8" lg; SS shaft 1/4" dia x 5/8" lg; AB type J39184; GCC Dwg P320-A-1081 (A-50473)	MOD AMP control
		<b>NOTE</b> <b>Do not replace with a wirewound resistor</b>	
R140		Not used	

Drawing numbers shown in ( ) apply to Contract NObsr 57567.

TABLE 6-4. TABLE OF REPLACEABLE PARTS

REF SYM	AF, STD NAVY, SIG CORPS STOCK NUMBER	NAME OF PART AND DESCRIPTION	FUNCTION
R141		Same as R138	Voltage dropping for 3v pilot lamps
R142	3300-399 812 018 N16-R-88341-8755 3Z7499-1.28	RESISTOR, variable: composition; 1 meg $\pm$ 20%; 1/2w; linear (U) taper; 3 solder lug term; enclosed metal case; 1-1/8" dia x 9/16" deep; 3/8"-32 x 3/8" lg bushing; 1/4" dia SS shaft; CTS type 35, spec #G-83 .ident #R-1551; GCC Dwg P320-B-375 (B-50396)	Sweep adjust (internal)
R143		Same as R125	SET ZERO voltage divider
R144		Same as R106	V105, V106 bleeder
R145		RESISTOR, special: disc type thermistor; for reference purposes only; GCC Dwg P320-A-60 (A-50641)	p/o Z109 (temp compensation for meter sensitivity)
R146		RESISTOR, special: bead thermistor; for reference purposes only; GCC Dwg P320-A-479 (A-50643)	p/o Z109 (RF power measurements)
R147		RESISTOR, special: disc type thermistor; for reference purposes only; GCC Dwg P320-A-52 (A-50642)	p/o Z109 (temp compensation for bridge voltage)
R201		RESISTOR, fixed: for reference purposes only; GCC Dwg P320-A-324 (A-50627)	p/o Z109 (calibration)
<b>SWITCHES</b>			
S101	3300-395 739 045 N17-S-74139-4844 3Z9849.135	SWITCH, toggle: DPDT; JAN type ST22N; 5 amp, 125vac; bat handle; spec JAN-S-23	Power ON-OFF
S102	- - N17-S-72018-9274 3Z9863-160	SWITCH, toggle: SPDT; JAN type ST17D; 5 amp, 125vdc, 2 amp 250vdc; bat handle; lugs; spec JAN-S-23	EXT MOD-INT FM
S103	- - N17-S-71894-1289 3Z9863-42F	SWITCH, toggle: SPDT; JAN type ST42F; 0.75 amp, 125vdc; one momentary position; bat handle; lugs; spec JAN-S-23	HIGH SENS bridge circuit
<b>TRANSFORMERS</b>			
T101	3300-296 937 732 N17-T-74295-2198 2Z9619-234	TRANSFORMER, power: 12 solder lug term; primary terms 1-2, 3.57 ohm $\pm$ 10%; 115v, 59-1600 cps; secondary terms 3-4, 6.3v @ 1.25 amp, 0.230 ohm $\pm$ 10%; secondary terms 5-6, 5v @ 2 amp, 0.155 ohm $\pm$ 10%; secondary terms 7-9, ctr tap at #8, 850-0-850v ((@ 29ma, 1812 ohm between terms 7-9; secondary terms 10-11, 6.3v @ 1.7 amp, 0.165 ohm $\pm$ 10%; term #12, electrostatic shield; max core loss 5w; 3-11/16" h x 2-7/8" w x 3-5/8" lg; fosterite finish; four 0.164"-32 x 1-5/8" lg rd hd mtg screws on 2-5/8" x 2-9/16" ctrs; Wemco type #7K7; GCC Dwg P320-C-20 (C-50397)	Power
T102	3300-296 949 068 N17-T-79551-5481 2Z9627-126	TRANSFORMER, pulse: six solder lug term; terms 1-2, 90 turns #33 wire, 2.6 ohm; terms 3-4, 90 turns #33 wire, 2.8 ohms; terms 5-6, 135 turns #38 wire, 14.6 ohm; Wemco type C core, 2 mils oriented, gnd; fosterite finish; 1-9/16" x 1-5/8" x 1-3/4" o/a; two 0.141" dia mtg holes on 1-1/8" ctr; Wemco type #7P9, 166AW2F; GCC Dwg P320-B-160 (B-50374)	Blocking oscillator

Drawing numbers shownn in ( ) apply to Contract NObsr 57567.

TABLE 6-4. TABLE OF REPLACEABLE PARTS

REF SYM	AF, STD NAVY, SIG CORPS STOCK NUMBER	NAME OF PART AND DESCRIPTION	FUNCTION
<b>AMPLIFIERS</b>			
U101	* - - N16-G-65491-1001 - -	AMPLIFIER UNIT, assembly: c/o E104, E105, E106, V107, V108, and associated parts: 2-7/16" w x 2-1/32" h x 5-9/16" deep; two input channels, one for low impedance low level (1N23A crystal) and one for high impedance high level for trigger; input voltages; square pulse 0.5 u sec, 1000 to 4000 cycles, 0.05 to 5.0 volts; and same except amplitude of from 2.0 to 150 volts; total voltage gain 500; metal cabinet; four 0.166" dia mtg holes on 5-1/8" x 1-13/16" ctrs; GCC Dwg P320-D-10 (D-50370)	Sawtooth generator and trigger amplifier
<b>TUBES</b>			
V101	3300-234 355 000 N16-T-55444 2J5R4GY	TUBE, electron: JAN type 5R4GY	Power rectifier
V102	3300-234 820 000 N16-T-56916 2J6Y6G	TUBE, electron: JAN type 6Y6G	Voltage regulator
V103	3300-234 710 000 N16-T-56660 2J6SH7	TUBE, electron: JAN type 6SH7	Regulator amplifier
V104	3300-234 198 990 N16-T-52625 2J2K25	TUBE, electron: JAN type 2K25	Oscillator
V105	3300-234 006 500 N16-T-53050 2J0C3/VR105	TUBE, electron: JAN type OC3/VR105	Voltage regulator
V106		Same as V105	Voltage regulator
V107	3300-234 750 000 N16-T-56677 2J6SL7GT	TUBE, electron: JAN type 6SL7GT	Amplifier
V108		Same as V107	Amplifier and blocking oscillator
<b>CABLES</b>			
W101	*1690-322 980 733 - - - -	CORD, RF: RG-9A/U; 51 ohm; grey; 30 mmf/ft capacity; 4000v RMS; 0.420" OD x 8' lg w/fittings; 7'10-3/4" lg w/o fittings; Navy type CG-92A/U (8'); includes P104 and P105; GCC Dwg P320-A-3 (A-50724)	RF output/input cable
W102	* - - - - - -	CORD, RF cable assembly; Navy type CG-530/U (6'); ASES RF coaxial cable RG-62/U; 93 ohms characteristic impedance; 750v max operating voltage; single conductor #22 AWG solid copper covered steel; air spaced polyethylene dielectric, 0.146" nominal dia; single copper braid shield; round; 0.242" o/a dia; black synthetic resin jacket; 6'5/8" lg o/a; 6' lg excluding terminations; ASES plug UG-260/U both ends (P102, P103) GCC Dwg P320-B-1074 (B-50727)	Video input/output cable
*Not furnished as a maintenance part. If failure occurs, do not request replacement unless the item cannot be repaired or fabricated. Drawing numbers shown in ( ) apply to Contract NObsr 57567.			

TABLE 6-4. TABLE OF REPLACEABLE PARTS

REF SYM	AF, STD NAVY, SIG CORPS STOCK NUMBER	NAME OF PART AND DESCRIPTION	FUNCTION
W103	*3300-322 001 039 - - 3E6000-337.72	CORD, power: 6 ft Simplex Wire & Cable type #SO; includes J104 and P106; 6'1" lg w/fittings; Navy type CX-337/U (6'); GCC Dwg P320-A-430 (A-50720)	Power input cable
<b>SOCKETS</b>			
X101	8850-889 919 N16-S-63515-1938 2Z8679.21	SOCKET, tube: octal; one-piece saddle mtg; circular plastic body; two 6-32 mtg bushings on 1-1/2" ctr; 1-13/16" dia x 13/16" h o/a; Cinch #51B13416, alternate construction; GCC Dwg P320-B-109 (S00-2200)	Hold V101
X102		Same as X101	Hold V102
X103		Same as X101	Hold V103
X 104		Not used	
X105		Same as X101	Hold V105
X106		Same as X101	Hold V106
X107		Same as X101	Hold V107
X108		Same as X101	Hold V108
X109	8850-889 917 - - - -	SOCKET, tube: octal; one-piece saddle mtg; circular black bakelite body; two 0.161" dia mtg holes 1-1/2" ctr; 1-7/8" lg x 1-9/32" w x 11/16" h; Amphenol type #MIP8; modify per GCC Dwg P320-A-261 (A-50685)	Hold V104 p/o Z107
<b>COMPONENTS</b>			
Z101	1600-327 305 619 N16-H-88041-2151 3F3988-68	ANTENNA, pick-up: aluminum alloy; black paladium finish; 3-5/16" lg x 2-7/32" h x 1-1/16" w o/a; JAN type AT-68/UP; GCC Dwg P320-B-4 (B-50713)	Pick-up antenna
Z102	Not used		
Z103	3300-286 054 677 - - 2Z307-95	WAVEGUIDE, RF output-detector section: coaxial; includes provisions to mount one crystal detector 1N23A crystal (CR10I); includes one special bypass mica capacitor (CI 116) and connector (J103); GCC Dwg P320-B-12 (B-50600)	Output/Input section
Z104	3300-291 643 468 N16-W-21991-1113 2Z4885-174	WAVEGUIDE, two E and one H plane bends; E plane bend 90°; 1-5/8" flanges; four 0.169" dia mtg holes on 1.280" x 1.220" ctrs, on ea flange; H plane bend 90°; 1-5/8" flanges, one ea end; four 0.189" dia mtg holes csk 90° x 1/4" on 1.280" x 1.220" mtg ctrs on ea flange; aluminum centrifugal casting alloy black finish; copper plate 0.001" thk; silver pl 0.001" thk; flash rhodium finish; one GCC Dwg P320-C-166, and one P320-B-168 make one GCC P320-B-17 (B-50700)	Waveguide
Z105	3300-286 066 437 - - 2Z394.74	ATTENUATOR, variable: calibrated; section of waveguide; waveguide contains glass strip coated with metallic film on one side; max attenuation attained when glass strip attenuator is centrally located in waveguide; min attenuation is attained when glass strip attenuator is close to wave guide surface; dial graduated in db with one mw as reference; 2-3/4" h X 6-1/2" lg x 1-7/8" w o/a; 2 mtg flanges, one ea end, w/0.169" dia mtg holes on 1.280" x 1.220" ctr; not symmetrical; GCC Dwg P320-C-16 (C-50484)	DBM attenuator

\*Not furnished as a maintenance part. If failure occurs, do not request replacement unless the item cannot be repaired or fabricated. Drawing numbers shown in ( ) apply to Contract NObsr 57567.



TABLE 6-4. TABLE OF REPLACEABLE PARTS

REF SYM	AF, STD NAVY, SIG CORPS STOCK NUMBER	NAME OF PART AND DESCRIPTION	FUNCTION
Z106	- - - - - -	DIAL AND WAVEMETER ASSEMBLY, frequency indicator: circular dial; calibrated in mc from 8430 to 9660; 7-3/4" lg x 7" OD; with barrel 5-7/8" OD, including tuning shaft and control mechanism; GCC Dwg P320-C-1003 (C-50541)	Absorption type frequency indicator
Z107	3300-293 353 521 - - 2Z6820.240	TUBE MOUNT, sub-assembly; c/o socket for V104 (X109), cover, screw and arm linkage for RF cut-off; 6-3/16" lg x 4" w X 5" h approx o/a; GCC Dwg P320-D-14 (D-50648)	Mount for RF oscillator V104
Z108	- - - - - -	MOUNTING, crystal rectifier subassembly: extractor post type; holds one JAN 1N23A ceramic cartridge type rectifying crystal; hollow phosphor bronze slotted extractor, 0.335" dia, finished bright alloy w/7/16" x 32 thd 3/4" from knob end, 1.479" lg x 0.532" dia; press fitted into knurled aluminum knob 11/16" lg x 7/8" dia, black anodized finish; 1-5/8" lg ol/a; GCC Dwg P320-A-371 (A-50605)	Holder for CR101 crystal rectifier; p/o Z103
Z109	- - - - - -	THERMISTOR, assembly: includes R145, R146, R147 and R201; cast aluminum, black finish; 3-19/32" x 2-31/32" x 2-17/32" o/a; GCC Dwg P320-D-1085 (D-50614)	Thermistor bridge wave guide section
Z110	3300-286 066 433 - - 2Z394.70	ATTENUATOR, adjustable: sub-assembly; dual position attenuator; 5 db and 40 db microwave attenuator, parallel vane type; glass strip coated with thin metallic film; 11-3/16" lg x 5-1/16" w x 3-1/4" h ol/a; eight (4 ea flange) 0.169" dia mtg holes on 1.280" x 1.220" mtg ctrs; GCC Dwg P320-D-18 (D-50568)	Dual position attenuator

Drawing numbers shown in ( ) apply to Contract NObsr 57567.

*TABLE 6-5. CROSS REFERENCE PARTS LIST*

<b>JAN NO.</b>	<b>KEY SYMBOL</b>	<b>JAN NO.</b>	<b>KEY SYMBOL</b>
AT-68/UP	Z101		
CM20D221J	CI111	ST17D	S102
CM35C103K	C103	ST22N	S101
CM35C512J	C115	ST42F	S103
CM35D472K	C108	OC3/VR105	V105
CP69BIEF503K	C102	1N23A	CR101
CP70EIDH405K	C101	2K25	V104
RA30AIFD152AD	R123	5R4GY	V101
RA30A1SA352AK	R124	6SH7	V103
RA40AIFD503AK	R137	6SL7GT	V107
RC20BF102K	R126	6Y6G	V102
RC20BF104K	R129		
RC20BF154K	R104	<b>NAVY TYPE</b>	<b>KEY SYMBOL</b>
RC20BF200J	R118		
RC20BF225K	R101	49825	P106
RC20BF333K	R103	CG-92A/U(8')	W101
RC20BF334K	R113	CG-530/U(6')	W102
RC20BF360J	R122	CX.337/U(6')	W103
RC20BF390J	R120		
RC20BF393K	R109	<b>ANA TYPE</b>	<b>KEY SYMBOL</b>
RC20BF471J	R121		
RC20BF682K	R135	CW-123/U	HI19
RC30BF204J	R10S	UG-21B/U	P104
RC30BF220K	R138	UG-260/U	P102
RC30BF304J	R107	UG-290/U	J102
RC30BF333K	R130	UG-397/U	E124
RC42BE103K	R106	UG-273/U	E125
RC42BE104K	R102	UG-446/U	E123
RC42BE682K	R125		

## CAPACITOR COLOR CODES

RMA 3-DOT COLOR CODE FOR MICA-DIELECTRIC CAPACITORS

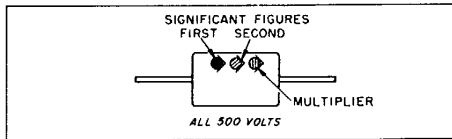

JAN 6-DOT COLOR CODE FOR PAPER-DIELECTRIC CAPACITORS

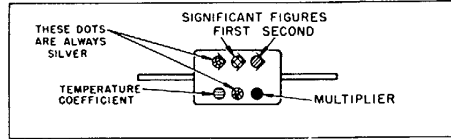

RMA 6-DOT COLOR CODE FOR MICA-DIELECTRIC CAPACITORS

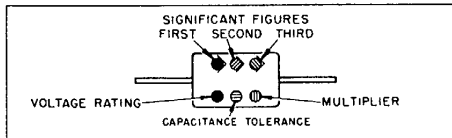

JAN 6-DOT COLOR CODE FOR MICA-DIELECTRIC CAPACITORS

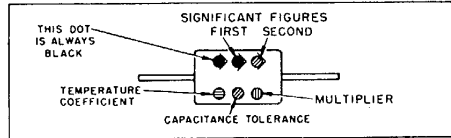

RMA COLOR CODE FOR TUBULAR CERAMIC-DIELECTRIC CAPACITORS

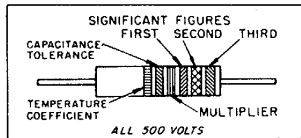

JAN COLOR CODE FOR FIXED CERAMIC-DIELECTRIC CAPACITORS  
RADIAL TYPE NON-INSULATED  
AXIAL TYPE INSULATED

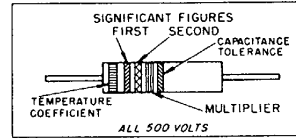
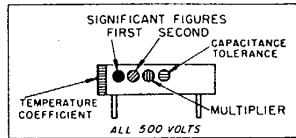

RMA RADIO MANUFACTURERS ASSOCIATION  
JAN JOINT ARMY-NAVY

RESISTORS				CAPACITORS				
TOLERANCE	MULTIPLIER	SIGNIFICANT FIGURE	COLOR	MULTIPLIER			VOLTAGE RATING	TEMPERATURE COEFFICIENT
				RMA MICA AND CERAMIC-DIELECTRIC	JAN MICA AND PAPER-DIELECTRIC	JAN CERAMIC DIELECTRIC		
	1	0	BLACK	1	1	1		A
	10	1	BROWN	10	10	10	100	B
	100	2	RED	100	100	100	200	C
	1000	3	ORANGE	1000	1000	1000	300	D
	10,000	4	YELLOW	10,000			400	E
	100,000	5	GREEN	100,000			500	F
	1,000,000	6	BLUE	1,000,000			600	G
	10,000,000	7	VIOLET	10,000,000			700	
	100,000,000	8	GRAY	100,000,000		0.01	800	
	1,000,000,000	9	WHITE	1,000,000,000		0.1	900	
5	0.1		GOLD	0.1	0.1		1000	
10	0.01		SILVER	0.01	0.01		2000	
20			NO COLOR				500	

## RESISTOR COLOR CODES

RMA COLOR CODE FOR FIXED COMPOSITION RESISTORS

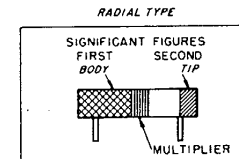
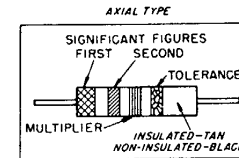

JAN COLOR CODE FOR FIXED COMPOSITION RESISTORS

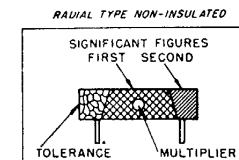
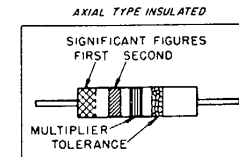

TABLE 6-6. APPLICABLE COLOR CODES AND MISCELLANEOUS DATA

**PARTS LISTS**  
**List of Manufacturers**

*TABLE 6-7. LIST OF MANUFACTURERS*

PREFIX	ABBREVIATION	NAME OF	COMPANY ADDRESS
CAW	Aerovox	Aerovox Corp.	740 Belleville Ave., New Bedford, Mass.
CBZ	AB	Allen-Bradley Co.	136 W. Greenfield St., Milwaukee, Wis.
CPH	Amphenol	American Phenolic Corp.	1830 So. 54th St., Chicago, Ill.
CAIS	Birtcher	Birtcher Corp., The	5087 Huntington Drive, Los Angeles, Calif.
CFA	Buss	Bussman Mfg. Co.	2538 W. University St., St. Louis, Mo.
CTC	CTS	Chicago Telephone and Supply Corp. 1	142 W. Beardsley Ave., Elkhart, Ind.
CMG	Cinch	Cinch Mfg. Co.	1026 So. Homan Ave., Chicago, Ill.
--	Harry Davies Mold Molding Co., The	Davies, Harry	1428 No. Wells St., Chicago, Ill.
CER	Erie	Erie Resistor Corp.	644 W. 12th St., Erie, Penna.
CGZ	*GCC	General Communication Co.	681 Beacon St., Boston, Mass.
CG	GE	General Electric Co.	1 River Rd., Schenectady, N. Y.
CBOK	*GRRF	General RF Fittings Co.	702 Beacon St., Boston, Mass.
--	--	Grant Gear Co.	Boston, Mass.
CGF	Gudeman Mfg.	Gudeman Mfg. Co.	361 W. Superior St., Chicago, Ill.
CHU	Hubbell	Hubbell, Harvey, Inc.	447 Concord Ave., Bridgeport, Conn.
CIR	IRC	International Resistance Co.	401 No. Broad St., Phila., Penna.
CAUP	Kurz-Kasch	Kurz-Kasch Inc.	1415 So. Broadway, Dayton, Ohio
CLF	Littlefuse	Littlefuse, Inc.	1865 Miner St., DesPlaines, Ill.
CJA	Millen	Millen, James A. Mfg. Co. Inc.	150 Exchange St., Malden, Mass.
CNA	National	National Co., Inc.	61 Sherman St., Malden, Mass.
CAO	WL	Ward-Leonard Co.	#6 South St., Mt. Vernon, N. Y.
CAY	Wemco	Westinghouse Electric & Mfg. Co.	East Pittsburg, Penna.
CW	Weston	Weston Electrical Instruments Corp.	619 Frelinghuysen Ave., Newark, N. J.
CA	White SS	SS White Dental Co.	10 E. 46th St., New York, N. Y.

\*Not an authorized abbreviation.

**ORIGINAL**

INDEX

SUBJECT	TABLE	FIGURE	PAGE
<b>A</b>			
Accessories .....	.....	1-3 .....	1-2
Accessories, Description of .....	.....	.....	1-2
Adapter connector (E123 and E124), description of .....	.....	.....	1-2
Adapter connector (E125), description of .....	.....	.....	1-2
Adjustments,			
General .....	.....	.....	5-8
Initial .....	.....	.....	3-2
Amplifier U101 schematic.....	.....	2-17 .....	2-6
Assembly of BNC type connectors .....	.....	5-15 .....	5-21
AT-68/UP (see Pick-up antenna)			
Attenuators, Description of .....	.....	.....	2-4
Attenuation, Theory of .....	.....	.....	2-4
Auxiliary equipment .....	.....	.....	1-3
Average to peak power conversion chart .....	.....	419.....	419
<b>B</b>			
Basic thermistor bridge circuit schematic .....	.....	2-25 .....	2-10
Beacon response of radar test .....	.....	.....	4-13
Bead thermistor .....	.....	2-23 .....	2-10
Block diagram of			
RF plumbing branches .....	.....	2-3 .....	2-2
Test set .....	.....	2-1 .....	2-0
Blocking oscillator sweep and external modulation circuit .....	.....	2-18 .....	2-7
Blocking oscillator sweep and external modulation circuit, Theory of .....	.....	.....	2-7
Bottom front view of chassis.....	.....	5-10 .....	5-15
Bottom rear view of chassis .....	.....	5-7 .....	5-12
Bottom view of video amplifier.....	.....	5-3 .....	5-3
<b>C</b>			
Calibration chart			
Typical .....	.....	4-2 .....	4-3
Use of .....	.....	.....	4-3
Case, Test Set CY-1302A/U .....	.....	1-2 .....	1-2
CG-92A/U (8') (see Cord CG-92A/U (8'))			
CG-530/U(6') (see RF cable assembly)			
Change in overall performance .....	.....	.....	4-18
Characteristics			
Rated tube .....	5-1 .....	.....	5-1
Reflex klystron .....	.....	2-21 .....	2-9
Chassis			
Bottom front view .....	.....	5-10 .....	5-15
Bottom rear view .....	.....	5-7 .....	5-12
Rear view .....	.....	5-2 .....	5-2
Right end view .....	.....	5-8 .....	5-13
Top rear view .....	.....	5-9 .....	5-14
Wiring diagram .....	.....	5-12 .....	5-17
Choke-flange joint .....	.....	2-5 .....	2-2
Cognizant Naval Inspector .....	.....	.....	1-3
Complete equipment .....	.....	1-1 .....	1-0
Connection diagram, Operation .....	.....	43.....	4-4

SUBJECT	TABLE	FIGURE	PAGE
Connectors, Function of control and .....	4-2 .....	.....	45
Continuous wave (see CW)			
Contractor .....	.....	.....	1-3
Contracts .....	.....	.....	1-3
Controls and connectors, Function of.....	4-2 .....	.....	4-5
Conversion chart			
Average to peak power.....	.....	4-19 .....	4-19
DBM to watts .....	.....	4-18 .....	4-18
Cord CG-92A/U(8')			
Calibration of attenuation.....	.....	.....	5-9
Description of.....	.....	.....	1-2
Fabrication notes .....	.....	5-14 .....	5-20
Use of .....	.....	.....	4-3
Cord CX-337/U(6'), Description of.....	.....	.....	1-2
Corrective maintenance, General.....	.....	.....	5-1
CX-337/U(6') (see Cord CX337/U(6'))			
Crystal complement, Tube and .....	1-5 .....	.....	1-5
Crystal replacement.....	.....	.....	5-7
CW signal equal to noise test.....	.....	.....	4-11
CW signal generator, Procedure for operating test set as a.....	.....	4-6 .....	4-7

**D**

Data			
Reference .....	.....	.....	1-3
Shipping.....	1-3 .....	.....	1-3
Winding.....	5-5 .....	.....	5-11
DBM calibrated attenuator.....	.....	2-12 .....	2-5
Replacement .....	.....	.....	5-5
Simplified phantom view.....	.....	2-13 .....	2-5
DBM control.....	.....	.....	4-5
DBM to watts conversion chart.....	.....	4-18 .....	4-18
DC resistance chart.....	5-2 .....	.....	5-7
DC voltage chart.....	5-3 .....	.....	5-8
Description			
General (Section 1)			
Physical .....	.....	.....	1-1
Dial lamp replacement.....	.....	.....	5-7
Difference in TS-147/UP series equipment.....	1-4 .....	.....	1-4
Directional couplers that may be used .....	.....	.....	1-3
Disc thermistor .....	.....	2-24 .....	2-10
Dual attenuator (see step attenuator)			

**E**

Electrical circuits, Theory of .....	.....	.....	2-6
Electrical general description.....	.....	.....	1-3
Equipment, Complete .....	.....	1-1 .....	1-10
Equipment differences.....	1-4 .....	.....	1-4
Equipment required and not supplied.....	1-2 .....	.....	1-2
Equipment supplied .....	1-1 .....	.....	1-1
External modulation, Procedure for.....	.....	.....	4-15
EXT MOD connector .....	.....	.....	4-5
EXT MOD-INT FM switch.....	.....	.....	4-5
F			
Failure report, Sample form.....	.....	5-1 .....	5-0
FM operation-tuning the test set to the receiver.....	.....	.....	4-4
FM signal generator, Procedure for operating test set as a.....	.....	4-7 .....	4-7
FM test set signals .....	.....	4-9 .....	48

SUBJECT	TABLE	FIGURE	PAGE
Formulas, List of tests and .....	4-1 .....	.....	4-1
FREQUENCY control .....	.....	.....	4-5
Frequency measurements of			
Input signals, General.....	.....	.....	2-2
Output signals, General.....	.....	.....	2-2
Frequency measuring, Simplified procedure for.....	.....	4-4 .....	4-6
Frequency meter assembly .....	.....	2-8 .....	2-4
Frequency meter assembly simplified phantom view.....	.....	2-9 .....	2-4
Frequency meter			
Description of.....	.....	.....	2-3
Reference data .....	.....	.....	1-5
Replacement .....	.....	.....	5-6
Frequency modulated (see FM)			
Front panel .....	.....	4-1 .....	4-0
Front panel replacement .....	.....	.....	5-5
Front panel view .....	.....	5-11 .....	5-16
Front view of wave guide.....	.....	5-5 .....	5-4
Function of components .....	8-2 .....	.....	8-2
Function of controls and connectors .....	4-2 .....	.....	4-5
Fuse replacement.....	.....	.....	5-7
<b>G</b>			
Gasket-flange joint .....	.....	2-4 .....	2-2
General description (Section J)			
General operating instructions .....	.....	.....	4-2
<b>H</b>			
HIGH SENS switch, Function of.....	.....	.....	45
<b>I</b>			
Impedances .....	.....	.....	1-5
Initial adjustment .....	.....	.....	3-2
Inspection .....	.....	.....	3-1
Inspection, Semiannual .....	.....	.....	5-1
Installation (Section 3)			
Introduction to operation.....	.....	.....	4-1
<b>J</b>			
Joint			
Choke-flange .....	.....	2-5 .....	2-2
Gasket-flange .....	.....	2-4 .....	2-2
<b>K</b>			
Klystron tube (see oscillator)			
<b>L</b>			
Lamp replacement.....	.....	.....	5-7
List of tests and formulas .....	4-1 .....	.....	4-1
Location .....	.....	.....	3-2
Lubrication .....	.....	.....	5-1
<b>M</b>			
Maintenance (Section 5)			
Measuring power with the thermistor bridge wattmeter.....	.....	.....	4-2
Meter, Frequency (see frequency meter)			
MOD AMP control.....	.....	.....	4-5
<b>O</b>			
115V AC connector .....	.....	.....	4-5
ON-OFF control.....	.....	.....	4-5

SUBJECT	TABLE	FIGURE	PAGE
Operating connection diagram .....	.....	4-3 .....	4-4
Operating maintenance repair parts .....	.....	.....	1-2, 5-6
Operation (Section 4)			
Operation of test set as a			
CW signal generator .....	.....	4-6 .....	4-7
FM signal generator .....	.....	4-7 .....	4-7
Frequency measuring device.....	.....	4-4 .....	4-6
Power measuring device .....	.....	4-5 .....	4-6
Pulsed signal generator .....	.....	4-8 .....	4-8
Operation			
Principles of .....	.....	.....	2-1
Theory of (Section 2)			
Operator's maintenance .....	.....	.....	5-1
Oscillator circuit			
Schematic .....	.....	2-19 .....	2-8
Theory of.....	.....	.....	2-8
Oscillator characteristics .....	.....	2-21 .....	2-9
Oscillator modulation .....	.....	2-22 .....	2-9
Oscillator mount (see tube mount)			
Oscillator output, General.....	.....	.....	2-1
Overall performance, Change in .....	.....	.....	4-18
Oscillator tube			
Cut-away view.....	.....	2-20 .....	2-8
Replacement .....	.....	.....	5-7
Oscillator, Tuning the .....	.....	.....	4-3
Oscilloscope, Use of.....	.....	.....	4-2
Outline dimensional drawing .....	.....	3-3 .....	3-3
<b>P</b>			
Parts lists (Section 6)			
Peak to average power conversion chart .....	.....	4-19 .....	4-19
Performance check .....	.....	.....	3-2
Performance data sheet, Sample radar .....	.....	4-15 .....	4-14
PHASE control.....	.....	.....	4-5
Physical description.....	.....	.....	1-1
Pick-up antenna			
Description of.....	.....	.....	1-2
Space loss .....	.....	.....	4-15
Plumbing branches, Block diagram showing.....	.....	2-3 .....	2-2
Plumbing, RF, arrangement .....	.....	2-2 .....	2-1
Power measurements, General.....	.....	.....	2-1
Power measuring .....	.....	4-5 .....	4-6
POWER SET control.....	.....	.....	4-5
Power supply circuits			
Reference data .....	.....	.....	1-5
Theory of.....	.....	.....	2-12
Preinstallation			
Check diagram .....	.....	3-2 .....	3-1
Test.....	.....	.....	3-1
Preliminary connections and adjustments.....	.....	.....	4-3
Preventive maintenance .....	.....	.....	5-1
Primary power distribution schematic diagram.....	.....	3-1 .....	3-1
PULSE ANALYZER.....	.....	.....	4-5
Pulse analyzer, Use of.....	.....	.....	4-5
Pulsed signal generator, Procedure for operating test set as a .....	.....	4-8 .....	4-8
<b>R</b>			
Radar overall performance figure, Computing the .....	.....	.....	4-18
Radar performance data sheet, Sample .....	.....	4-15 .....	4-14



SUBJECT	TABLE	FIGURE	PAGE
Radar receiver tuning .....	.....	.....	4-13
Rated tube characteristics .....	5-1 .....	.....	5-1
Rear view, Chassis .....	.....	5-2 .....	5-2
Rear view of wave guide .....	.....	5-6 .....	5-4
Receiver bandwidth measurement test .....	.....	.....	4-10
Receiver frequency test .....	.....	.....	49
Receiver performance figure (using FM) test .....	.....	.....	4-11
Receiver performance formula .....	.....	.....	4-17
Receiver tuning .....	.....	.....	4-13
Reference data .....	.....	.....	1-3
Reflex klystron characteristics .....	.....	2-21 .....	2-9
Removal of units .....	.....	.....	5-1
Resistance chart, DC .....	5-2 .....	.....	5-7
Resistances of windings .....	5-5 .....	.....	5-11
RF cable assembly, Description of .....	.....	.....	1-2
RF connector .....	.....	.....	4-5
RF input/output section (see RF output and detector section)	.....	.....	.....
RF oscillator circuit .....	.....	2-19 .....	2-8
RF output and detector section .....	.....	2-16 .....	2-6
Description of .....	.....	.....	2-6
Replacement .....	.....	.....	5-5
RF plumbing,	.....	.....	.....
Arrangement .....	.....	2-2 .....	2-1
Components, General description of .....	.....	.....	2-1
Maintenance of .....	.....	.....	5-2
RF wattmeter reference data .....	.....	.....	1-5
Right end view of chassis .....	.....	5-8 .....	5-13
<b>S</b>	.....	.....	.....
Sawtooth sweep reference data .....	.....	.....	1-5
Schematic of	.....	.....	.....
Basic thermistor bridge circuit .....	.....	2-25 .....	2-10
Blocking oscillator sweep and external modulation circuit .....	.....	2-18 .....	2-7
Complete thermistor bridge circuit .....	.....	2-28 .....	2-11
Oscillator circuit .....	.....	2-19 .....	2-8
Test Set TS-147D/UP complete .....	.....	5-16 .....	5-23
Thermistor bridge circuit showing	.....	.....	.....
Sensitivity compensation .....	.....	2-26 .....	2-11
Voltage compensation .....	.....	2-27 .....	2-11
Trigger detector and amplifier circuit .....	.....	2-17 .....	2-6
SET ZERO-COARSE adjustment .....	.....	.....	5-8
SET ZERO-FINE and COARSE controls .....	.....	.....	4-5
Shipping data .....	1-3 .....	.....	1-3
SIGNAL FREQ control .....	.....	.....	4-5
Signal generator reference data .....	.....	.....	1-3
SIGNAL WIDTH control .....	.....	.....	4-5
Step attenuator .....	.....	2-14 .....	2-5
Step attenuator simplified phantom view .....	.....	2-15 .....	2-6
Supplied, Equipment .....	1-1 .....	.....	1-1
Sweep adjust potentiometer adjustment .....	.....	.....	5-8
Synthetic target .....	.....	.....	4-13
<b>T</b>	.....	.....	.....
TEST control .....	.....	.....	4-5
Tests and formulas, List of .....	4-1 .....	.....	4-1
Test set	.....	.....	.....
Accessories .....	.....	1-3 .....	1-2
Block diagram .....	.....	2-0 .....	2-1

SUBJECT	TABLE	FIGURE	PAGE
Chassis			
Bottom front view .....	.....	5-10 .....	5-15
Bottom rear view .....	.....	5-7 .....	5-12
Rear view .....	.....	5-2 .....	5-2
Right end view .....	.....	5-8 .....	5-13
Top rear view .....	.....	5-4 .....	5-14
Complete schematic .....	.....	5-16 .....	5-23
Front panel .....	.....	4-1, 5-1 .....	4-0, 5-16
General description .....	.....	.....	1-1
Outline dimensional drawing .....	.....	3-3 .....	3-3
Schematic .....	.....	5-16 .....	5-23
Stowed for carrying .....	.....	1-2 .....	1-2
Theory of operation (Section 2)			
Thermistor, Bead .....	.....	2-23 .....	2-10
Thermistor bridge circuit			
Complete .....	.....	2-28 .....	2-11
Showing sensitivity compensation .....	.....	2-26 .....	2-11
Showing voltage compensation .....	.....	2-27 .....	2-11
Theory of .....	.....	.....	2-10
Thermistor, Disc .....	.....	2-24 .....	2-10
Thermistor mount .....	.....	2-10 .....	2-4
Description of .....	.....	.....	2-3
Replacement .....	.....	.....	5-6
Simplified phantom view .....	.....	2-10 .....	2-5
Top view of video amplifier .....	.....	5-4 .....	5-3
Top view of chassis .....	.....	5-9 .....	5-14
Tube and crystal complement .....	1-5 .....	.....	1-5
Tube characteristics, Rated .....	5-1 .....	.....	5-1
Tube maintenance .....	.....	.....	5-7
Tube mount assembly .....	.....	2-7 .....	2-3
Description of .....	.....	.....	2-2
Simplified phantom view .....	.....	2-6 .....	2-3
Tuning the oscillator .....	.....	.....	4-3
Transmitter average power			
Above + 10 dbm test .....	.....	.....	4-4
Below + 10 dbm test .....	.....	.....	44
Formula .....	.....	.....	417
In dbm, Computing rated __; .....	.....	.....	418
Transmitter frequency test .....	.....	.....	49
Transmitter performance figure, Computing the .....	.....	.....	4-11
Transmitter pulling and AFC tracking .....	.....	.....	4-13
TRIGGER connector .....	.....	.....	4-5
Trigger detector and amplifier circuit			
Schematic .....	.....	2-17 .....	2-6
Theory of .....	.....	.....	2-6
Troubles and remedies .....	5-4 .....	.....	5-10
TR recovery time (using FM) test .....	.....	.....	4-12
TR recovery time (using CW) test .....	.....	.....	4-12
TS-147/UP equipment differences .....	1-4 .....	.....	1-4
<b>U</b>			
Unpacking .....	.....	.....	3-1
<b>V</b>			
Video Amplifier (see also amplifier and blocking oscillator)			
Bottom view .....	.....	5-3 .....	5-3
Top view .....	.....	5-4 .....	5-3
Wiring Diagram .....	.....	5-13 .....	5-19
Voltage chart, DC .....	5-3 .....	.....	5-8

SUBJECT	TABLE	FIGURE	PAGE
<b>W</b>			
Watts to dbm conversion chart.....		4-18	418
Wave guide (see also RF plumbing)			
Assembly .....		2-2	2-1
Front view .....		5-5	5-4
Rear view.....		5-6	5-4
Weights .....		1-1	1-1
Wiring diagram of			
Chassis.....		5-12	5-17
Video amplifier.....		5-13	5-19

[AG 413.44 (11 May 56) ]

By Order of *Wilber M. Brucker*, Secretary of the Army:

MAXWELIL D. TAYLOR,  
*General, United States Army,*  
*Chief of Staff.*

Official:

JOHN A. KLEIN,  
*Major General, United States Army,*  
*The Adjutant General.*

Distribution:

Active Army:

CNGB (1)	Gen & Br Svc Sch (5) except	lowing TOE's:
ASA (3)	Sig Sch (25)	11-7C, Sig Co, Inf Div (2)
Tec Svc, DA (1) except	Gen Depots (2) except	11-16C, Hq & Hq Co, Sig
CSIGO (30)	Atlanta Gen Depot (None)	Bn, Corps or Abn Corps
Tec Svc Bd (1)	Sig Sec, Gen Depots (10)	(2)
Hq CONARC (5)	Sig Depots (20)	11-57C, Armd Sig Co (2)
CONARC Bd (Incl ea Test	Sp Wpn Comd (2)	11-127R, Sig Rep Co (2)
Sec) (1)	POE (OS) (2)	11-128R, Sig Depot Co (2)
Army AA Comd (2)	Trans Terminal Comd (2)	11-500R (AA-AE), Sig Svc
OS Maj Comd (5)	Army Terminals (2)	Org (2)
OS Base Comd (5)	OS Sup Agencies (2)	11-557C, Abn Sig Co (2)
Log Comd (5)	Army Elct PG (1)	11-587R, Sig Base Maint
MDW (1)	Sig Fld Maint Shops (3)	Co (2)
Armies (5)	Sig Lab (5)	11-592R, Hq & Hq Co, Sig
Corps (2)	Mil Dist (1)	Base Depot (2)
Tng Div (2)	ACS (3)	11-597R, Sig Base Depot
Ft & Cp (2)	Units organized under fol-	Co (2)

NG: State AG (6); units-same as Active Army except allowance is one copy per unit.

USAR: None.

For explanation of abbreviations used, see SR 32-50-1.

\*U.S. GOVERNMENT PRINTING OFFICE: 1992 -311-831/60747

RECOMMENDED CHANGES TO EQUIPMENT TECHNICAL PUBLICATIONS



THEN... JOT DOWN THE DOPE ABOUT IT ON THIS FORM, CAREFULLY TEAR IT OUT, FOLD IT AND DROP IT IN THE MAIL!

**SOMETHING WRONG** WITH THIS PUBLICATION?

FROM: (PRINT YOUR UNIT'S COMPLETE ADDRESS)

DATE SENT

PUBLICATION NUMBER	PUBLICATION DATE	PUBLICATION TITLE
--------------------	------------------	-------------------

BE EXACT... PIN-POINT WHERE IT IS				IN THIS SPACE TELL WHAT IS WRONG AND WHAT SHOULD BE DONE ABOUT IT:
PAGE NO.	PARA-GRAPH	FIGURE NO.	TABLE NO.	

PRINTED NAME, GRADE OR TITLE, AND TELEPHONE NUMBER	SIGN HERE:
--	------------

TEAR ALONG PERFORATED LINE

DA FORM 2028-2  
1 JUL 79

PREVIOUS EDITIONS ARE OBSOLETE.

P.S.—IF YOUR OUTFIT WANTS TO KNOW ABOUT YOUR RECOMMENDATION MAKE A CARBON COPY OF THIS AND GIVE IT TO YOUR HEADQUARTERS.

